

RS(D)Q, Stopper Cylinder, Fixed Mounting Height RSDQB12-10T

Datasheet

General series information

- Fixed height stopper cylinder
- Double acting & single acting available
- Bore sizes: 12mm
- Stroke range: 10mm to 30mm
- Auto switch capable



Single acting cylinder / Extended / Magnet
Return by spring

Standard specifications

Magnet	D (Built-in)
Mounting	B (Through Hole (Standard))
Bore Size	12mm
Piping	Rc (or Metric)
Stroke	10mm
Action	T (Single Acting/Spring Extend)
Rod End	Round Bar Style
Auto Switch	No Switch
Lead Wire or Prewired Connector	0.5m (Or None in the Case of No Switch)
Number	2 pcs. (Or None in the Case of No Switch)
Maximum operating pressure	1 MPa
Proof pressure	1.5 MPa
Maximum ambient temperature	70 °C
Maximum ambient temperature with magnet	60 °C
Minimum ambient temperature	-10 °C (No freezing)
Minimum ambient temperature with magnet	-10 °C (No freezing)
Conform to the European RoHS Directive	Conform
Maximum piston speed	500 mm/s

Type of cushioning	Rubber bumper
Minimum piston speed	50 mm/s
Lubrication	Non-Lube
Stroke length tolerance	$\pm 0 \sim 1.4$ mm
F450 - Mounting	Through-hole, both ends tapped
Action	Single acting / spring extend

Dimensions

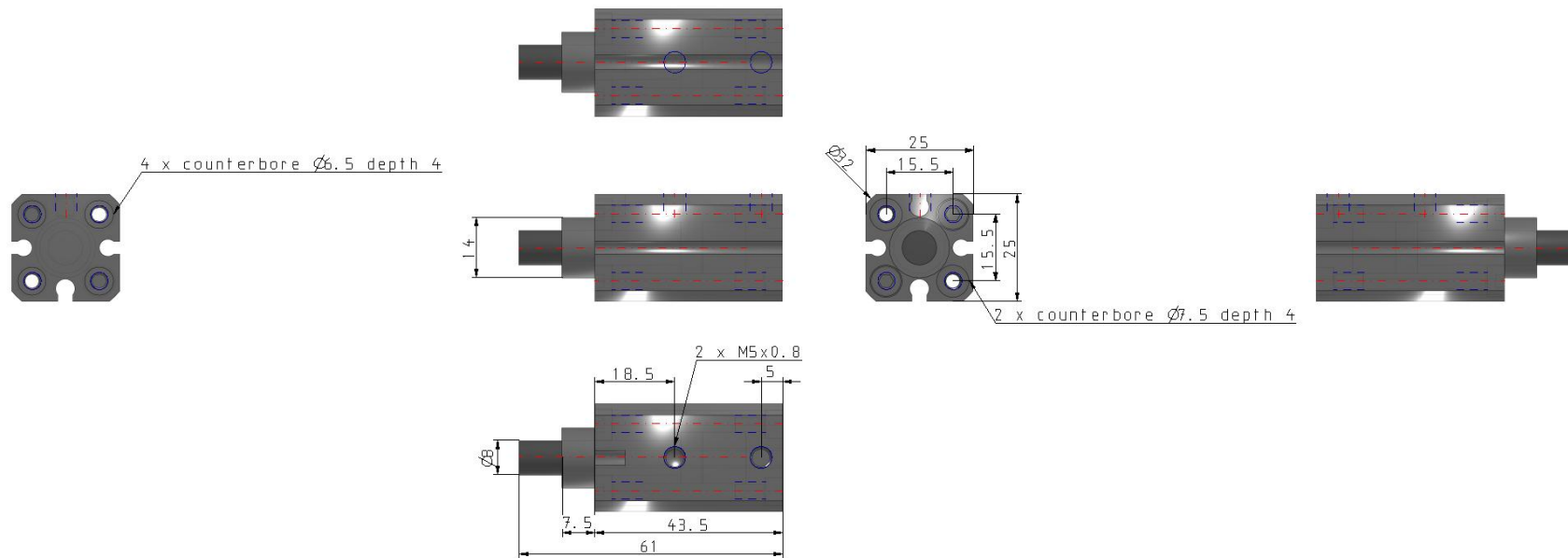

Additional information

Catalogue

[RSQ_RSG_EU.pdf](#)