

Vacuum Regulator

New

RoHS

Single Sided Connections Series

For ease of installation and panel mounting



Weight reduced by **20%**
(Compared with the existing IRV2000 with IRV20 fitting)

New and Improved
IRV Series

Max. flow
(Over twice the flow of the existing models)

140 ℓ/min (ANR)
Existing IRV1000:
60 ℓ/min (ANR)

240 ℓ/min (ANR)
Existing IRV2000:
100 ℓ/min (ANR)

Standard connections



Series **IRV10/20**



CAT.ES60-20B

Easy to attach/detach the pressure gauge or digital pressure switch due to attachment by clip.

Mounting direction of the pressure gauge or digital pressure switch can be changed. (Standard connections only)

Standard connections

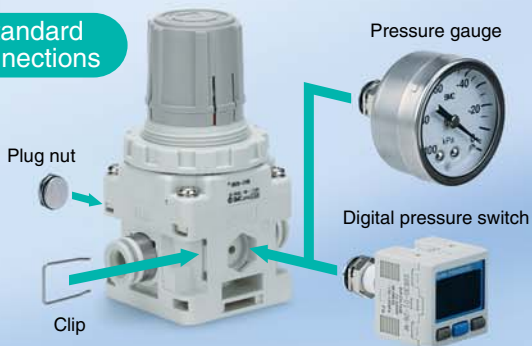

Single sided connections

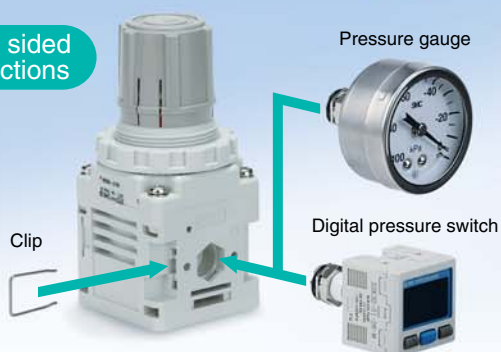

Mounting angle of the pressure gauge or digital pressure switch can be changed easily (in 60 degree increments).



Mounting Variations

Standard connections

Single sided connections

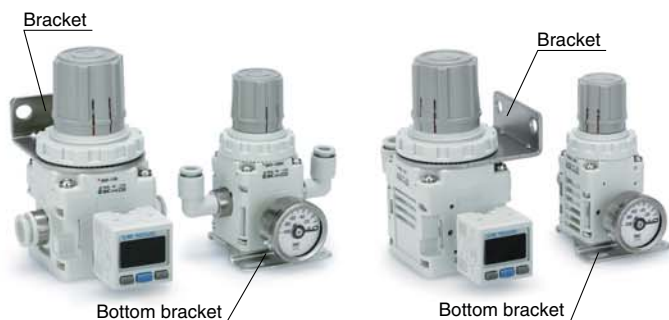

Built-in One-touch fittings

Different size options for both fitting types

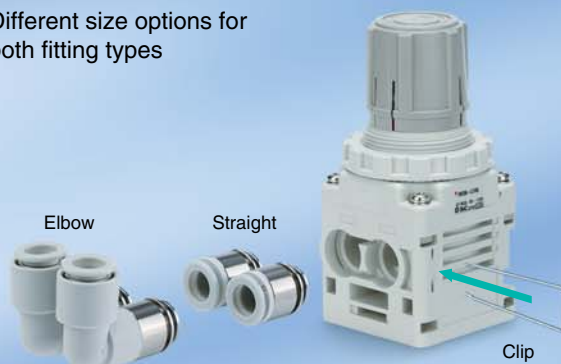

Fitting type	Applicable tubing O.D. (mm)	Model	
		IRV10	IRV20
Straight	ø6	●	●
	ø8	●	●
Elbow	ø10	—	●
	ø1/4"	●	●
	ø5/16"	●	●
	ø3/8"	—	●

Standard connections

Single sided connections



Applications

Vacuum lift

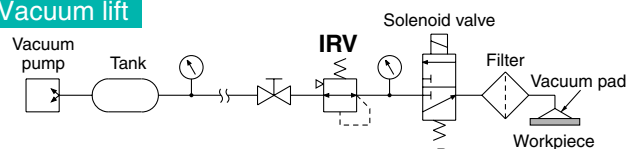

Leak tester

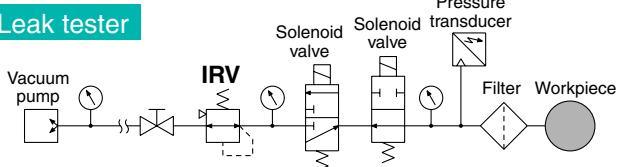

Vacuum Regulator

Series IRV10/20



How to Order

Standard connections

IRV 20 - [] C08 [] []

Body size

10	Max. flow 140 ℓ/min (ANR)
20	Max. flow 240 ℓ/min (ANR)

Fittings

Nil	Straight
L	Elbow



Straight

Elbow

Connection tubing O.D.

Symbol	Tubing O.D.	IRV10	IRV20
C06	Metric	●	●
C08		●	●
C10		—	●
N07	Inch	●	●
N09		●	●
N11		—	●

Accessory ②

Nil	None Note 1)		
G	With pressure gauge Note 2) Note 3) (IRV10: With GZ33-K-01, IRV20: With GZ43-K-01)		
ZN	With Note 3) digital pressure switch	NPN open collector 1 output	With ZSE30A-01-N-ML
ZP		PNP open collector 1 output	With ZSE30A-01-P-ML
ZA		NPN open collector 2 outputs	With ZSE30A-01-A-ML
ZB		PNP open collector 2 outputs	With ZSE30A-01-B-ML

Note 1) Two plug nuts are mounted on the gauge port. When the Rc1/8 port is required, please order the optional gauge nut assembly P601010-18 separately. (Refer to page 8.)

Note 2) Pressure gauge accuracy: Within ±3% of full scale

Note 3) Plug nut and gauge nut are included. (For details, refer to back page 1.)
Accessories are included in the same container.

Accessory ① Note 1)

Nil	None
B	With bracket
L	With bottom bracket

Note 1) Accessories are shipped together.

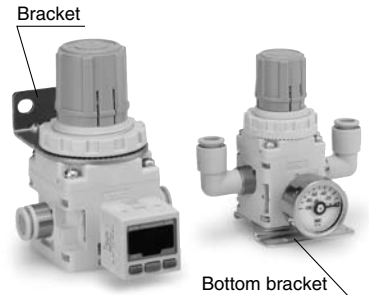

Bottom bracket

Single sided connections

IRV 20 A - [] C08 [] [] - []

Body size

10	Max. flow 140 ℓ/min (ANR)
20	Max. flow 240 ℓ/min (ANR)

Single sided connections

A	Single sided connections
---	--------------------------

Fittings

Nil	Straight
L	Elbow

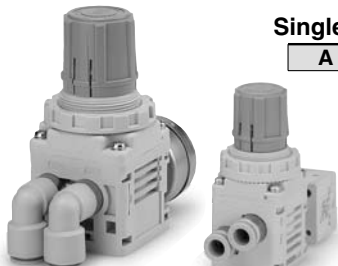

Elbow

Straight

Connection tubing O.D.

Symbol	Tubing O.D.	IRV10A	IRV20A
C06	Metric	●	●
C08		●	●
C10		—	●
N07	Inch	●	●
N09		●	●
N11		—	●

Made to Order

For details, refer to page 10.

Symbol	Specification
X1	Integrated digital pressure switch for panel mounting

Accessory ②

Nil	None Note 1)		
G	With pressure gauge Note 2) Note 3) (IRV10A: With GZ33-K-01, IRV20A: With GZ43-K-01)		
ZN	With Note 3) digital pressure switch	NPN open collector 1 output	With ZSE30A-01-N-ML
ZP		PNP open collector 1 output	With ZSE30A-01-P-ML
ZA		NPN open collector 2 outputs	With ZSE30A-01-A-ML
ZB		PNP open collector 2 outputs	With ZSE30A-01-B-ML

Note 1) Two plug nuts are mounted on the gauge port. When the Rc1/8 port is required, please order the optional gauge nut assembly P601010-18 separately. (Refer to page 8.)

Note 2) Pressure gauge accuracy: Within ±3% of full scale

Note 3) Gauge nut is included. Accessories are included in the same container.

Accessory ① Note 1)

Nil	None
B	With bracket
L	With bottom bracket

Note 1) Accessories are shipped together.

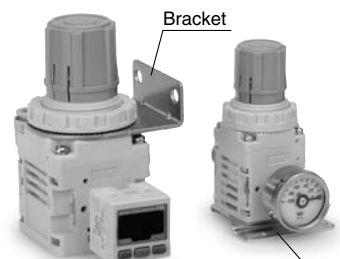

Bottom bracket

Series IRV10/20

Standard Specifications

Model		IRV10	IRV20
Fluid		Air	
Set pressure range <small>Note 1)</small>		-100 to -1.3 kPa	
Withstand pressure <small>Note 2)</small>		100 kPa (Except with pressure gauge)	
Atmospheric intake consumption <small>Note 3)</small>		0.6 ℓ/min (ANR) or less	
Knob resolution		0.13 kPa or less	
Ambient and fluid temperature		5 to 60°C	
VAC side tubing O.D.		ø6, ø8	ø6, ø8, ø10
SET side tubing O.D.		ø1/4", ø5/16"	ø1/4", ø5/16", ø3/8"
Weight (Without accessories)	Standard connections	135 g (IRV10-C08)	250 g (IRV20-C10)
	Single sided connections	125 g (IRV10A-C08)	250 g (IRV20A-C10)

Note 1) Use caution it varies depending on the pressure in vacuum pump side.

Note 2) For vacuum regulators with a pressure gauge, the pressure gauge will be damaged if positive pressure is supplied. In the event that positive pressure is applied, the vacuum regulator will not be damaged; however, the main valve will open and positive pressure will enter the vacuum pump. This may cause malfunction of the vacuum pump. when the vacuum regulator is used in the adsorbing and transferring system, refer to the following piping example and avoid supplying positive pressure to the vacuum pump. The vacuum regulator cannot adjust positive pressure.

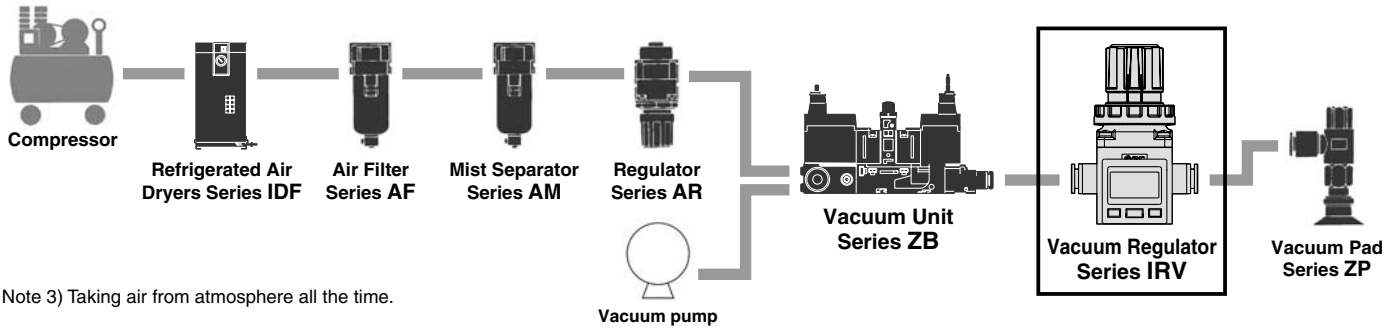

Note 3) Taking air from atmosphere all the time.

Conditions:
 Vacuum pump exhaust speed:
 2500 ℓ/min
 VAC side pressure:
 -101 kPa (At initial setting)

Flow-rate Characteristics (Representative Value)

IRV10-C08 (One-touch fitting ø8)

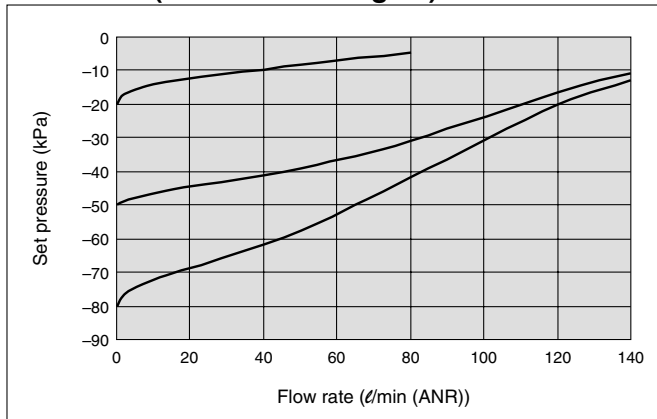

IRV20-C10 (One-touch fitting ø10)

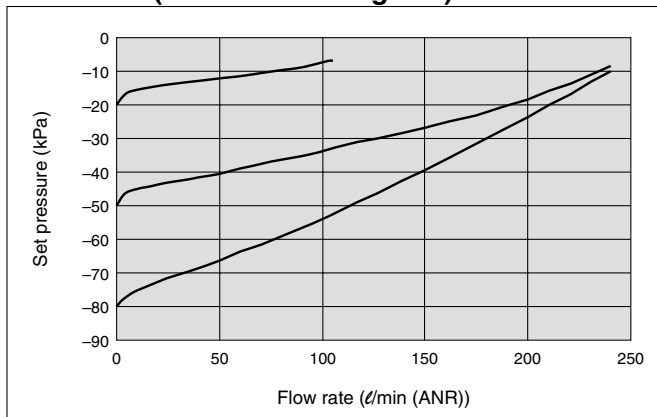

Pressure Characteristics (Representative Value)

IRV10

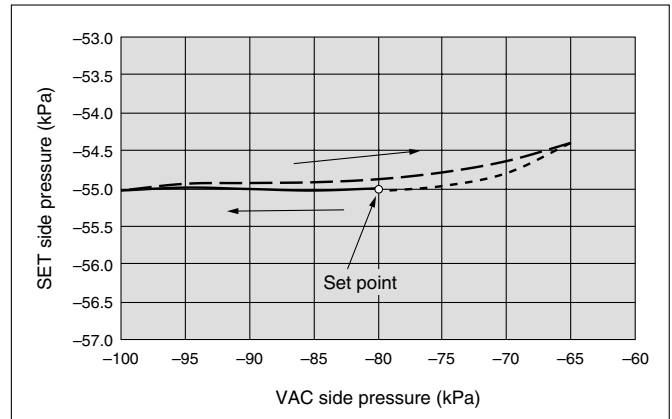

IRV20

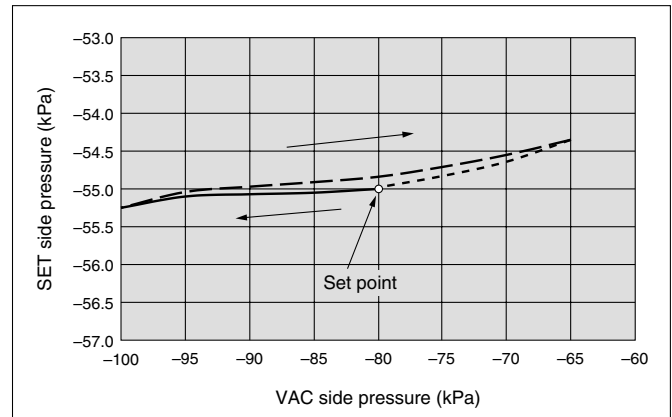

Construction

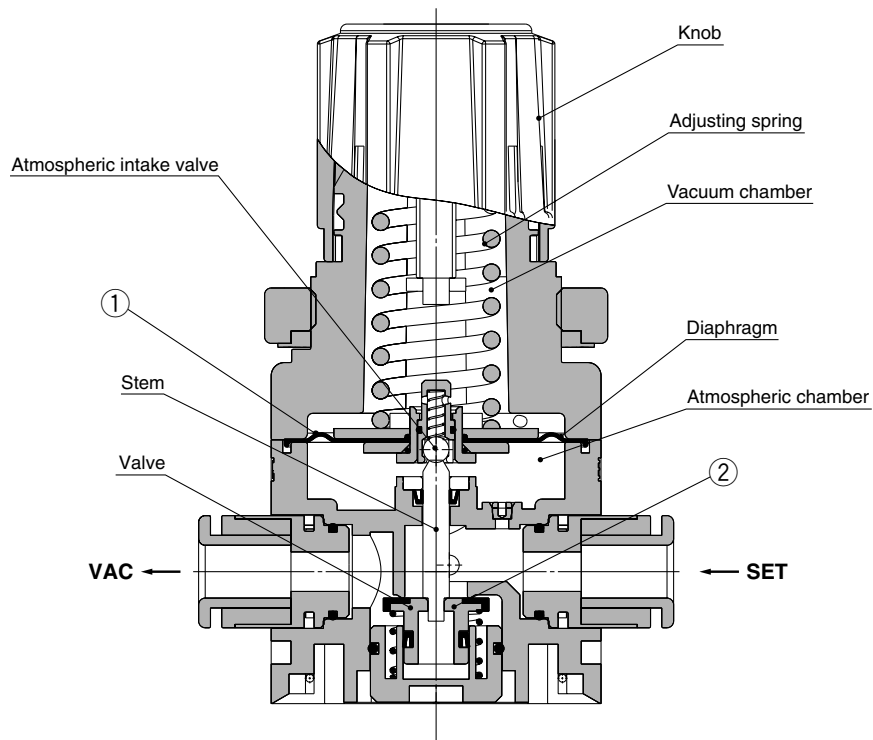

Working principle

When the knob is turned to the right (clockwise), the adjusting spring's generated force pushes down the diaphragm and the valve. This connects the VAC side and SET side, and the degree of vacuum on the SET side increases (becomes closer to an absolute vacuum). Furthermore, the SET side vacuum pressure moves through the air passage into the vacuum chamber, where it is applied to the top side of the diaphragm and counters the adjusting spring's compression force; and this adjusts the SET side pressure. When the degree of vacuum on the SET side is higher than the designated setting value (becomes closer to an absolute vacuum), the balance between the adjusting spring and the SET side pressure in the vacuum chamber is lost, and the diaphragm is pushed up. This causes the valve to close and the atmospheric intake valve to open, which lets atmospheric air into the SET side. When the adjusting spring's compression force and the SET side pressure are balanced, the SET side pressure is set. Also, when the degree of vacuum of the SET side pressure is lower than the designated setting value (becomes closer to the atmosphere), the balance between the adjusting spring and the vacuum chamber is lost, and the diaphragm is pushed down. This causes the atmospheric intake valve to close and the valve to open, which lets air into the VAC side. When the adjusting spring's compression force and the SET side pressure are balanced, the SET side pressure is set.

Replacement Parts

No.	Description	Material	Part no.	
			IRV10	IRV20
1	Diaphragm assembly	HNBR, etc.	P601010-2	P601020-2
2	Valve assembly	HNBR, etc.	P601010-3	P601020-3

Series IRV10/20

Dimensions/IRV10: Standard Connections

IRV10-□□□G: With pressure gauge

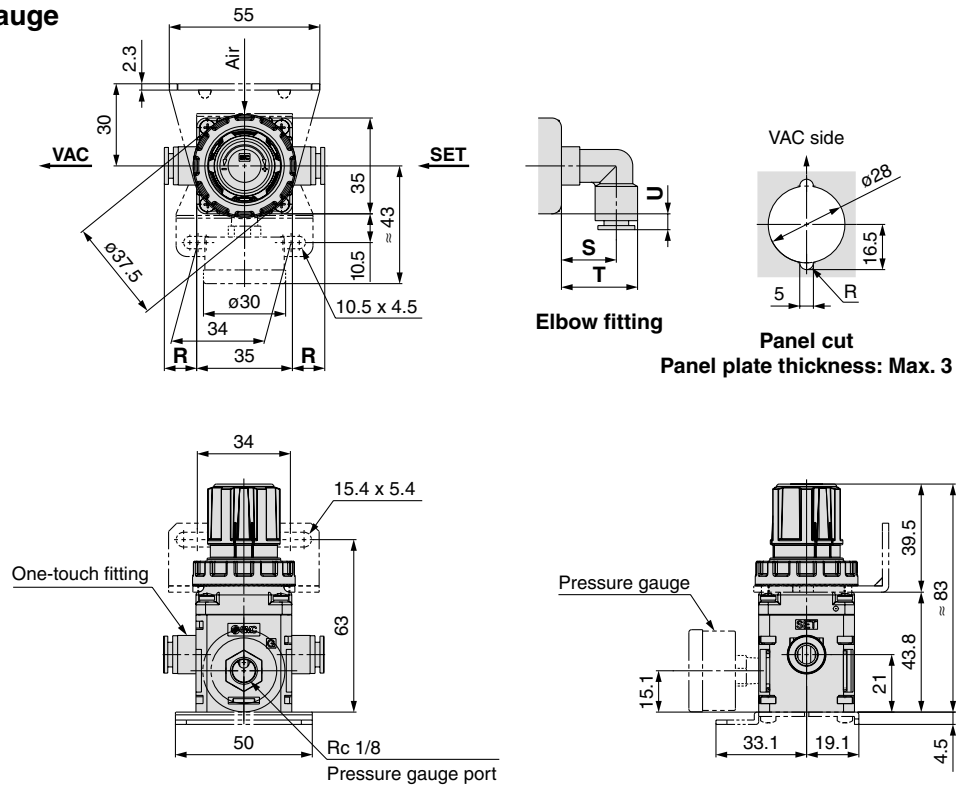

Fitting Part Dimensions (mm)

Fitting size	VAC/SET			
	Straight	Elbow	Elbow	Elbow
	R	S	T	U
ø6, ø1/4"	10	19	26	3
ø8, ø5/16"	12	20	28	6

IRV10-□□□Z^N_A^P_B: With digital pressure switch

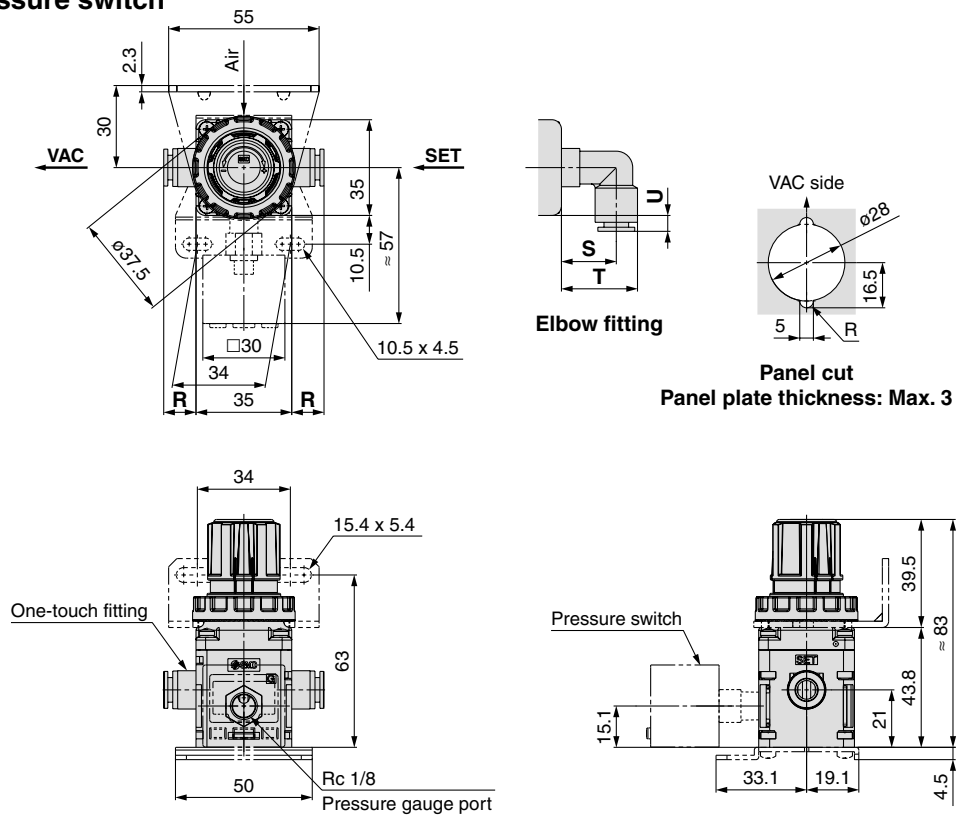

Fitting Part Dimensions (mm)

Fitting size	VAC/SET			
	Straight	Elbow	Elbow	Elbow
	R	S	T	U
ø6, ø1/4"	10	19	26	3
ø8, ø5/16"	12	20	28	6

Dimensions/IRV10A: Single Sided Connections

IRV10A-□□□G: With pressure gauge

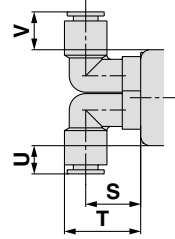
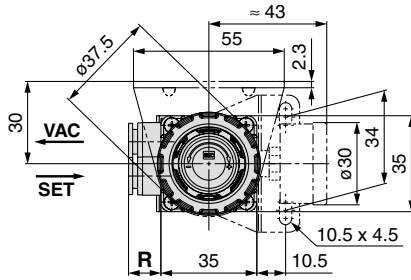

Elbow fitting

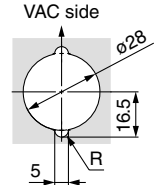

Panel cut

Panel plate thickness: Max. 3

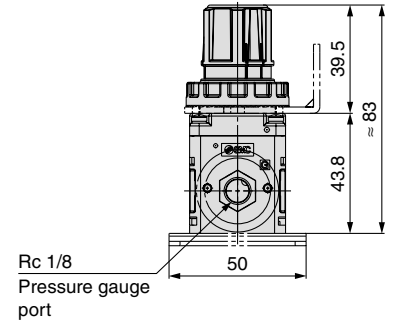
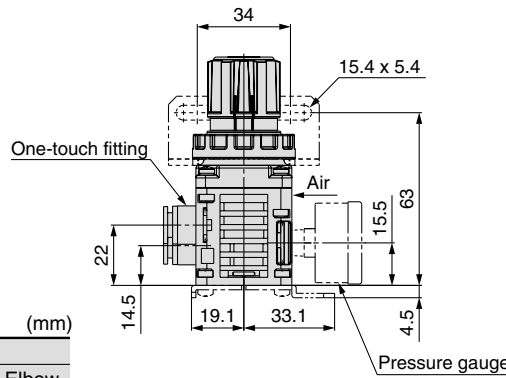

Fitting Part Dimensions

(mm)

Fitting size	VAC/SET				
	Straight	Elbow	Elbow	Elbow	Elbow
	R	S	T	U	V
ø6, ø1/4"	10	19	26	7.5	11
ø8, ø5/16"	12	20	28	10.5	14

IRV10A-□□□^N_A^P_B: With digital pressure switch

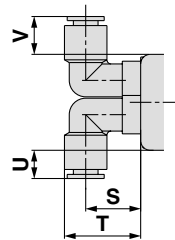
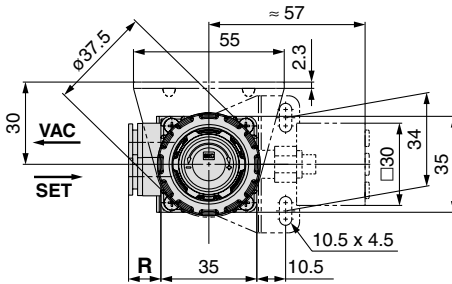

Elbow fitting

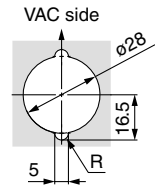

Panel cut

Panel plate thickness: Max. 3

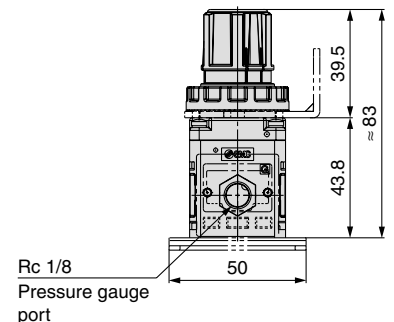
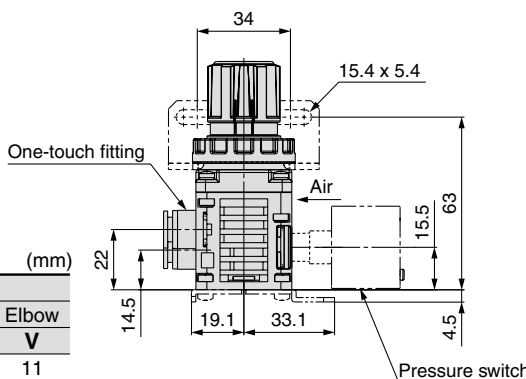

Fitting Part Dimensions

(mm)

Fitting size	VAC/SET				
	Straight	Elbow	Elbow	Elbow	Elbow
	R	S	T	U	V
ø6, ø1/4"	10	19	26	7.5	11
ø8, ø5/16"	12	20	28	10.5	14

Series IRV10/20

Dimensions/IRV20: Standard Connections

IRV20-□□□G: With pressure gauge

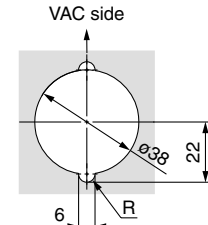
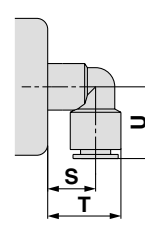
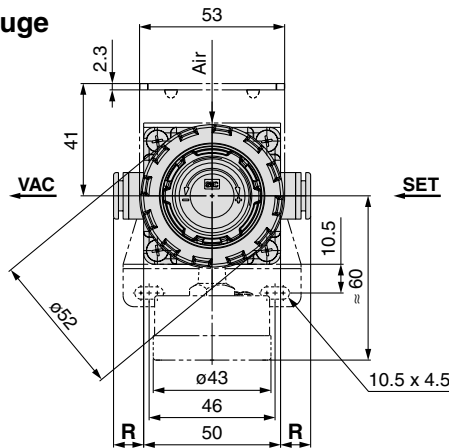

Elbow fitting

Panel cut
Panel plate thickness: Max. 4

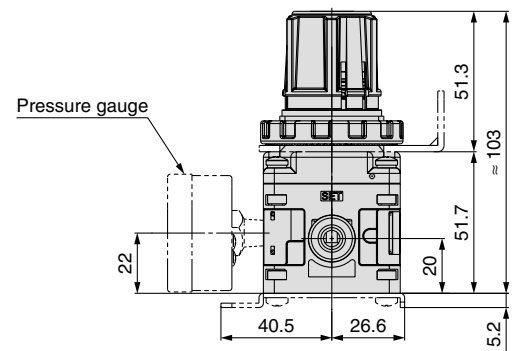
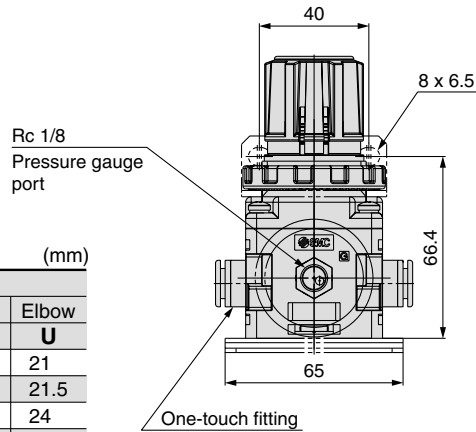

Fitting Part Dimensions (mm)

Fitting size	VAC/SET			
	Straight R	Elbow S	Elbow T	Elbow U
ø6	10.5	21	27.5	21
ø1/4"	10.5	21	27.5	21.5
ø8, ø5/16"	10.5	21	28.5	24
ø10, ø3/8"	11	21	30.5	27

IRV20-□□□Z^N_A^P_B: With digital pressure switch

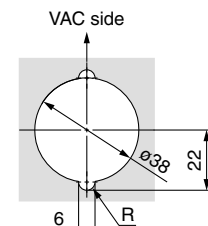
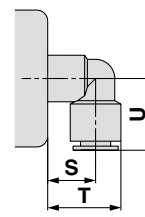
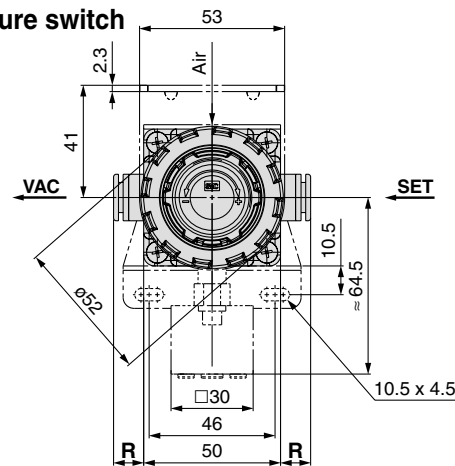

Elbow fitting

Panel cut
Panel plate thickness: Max. 4

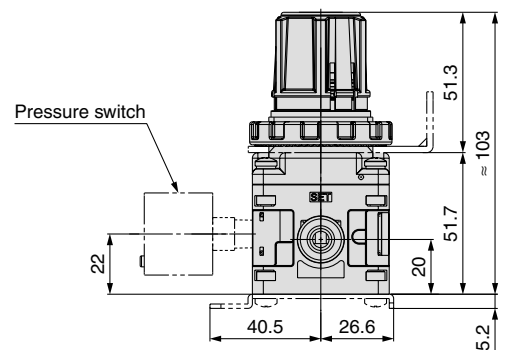
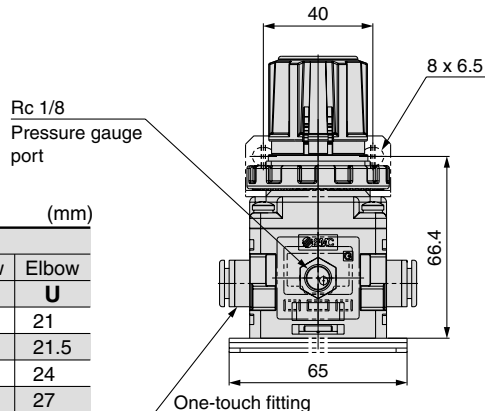

Fitting Part Dimensions (mm)

Fitting size	VAC/SET			
	Straight R	Elbow S	Elbow T	Elbow U
ø6	10.5	21	27.5	21
ø1/4"	10.5	21	27.5	21.5
ø8, ø5/16"	10.5	21	28.5	24
ø10, ø3/8"	11	21	30.5	27

Dimensions/IRV20A: Single Sided Connections

IRV20A-□□□G: With pressure gauge

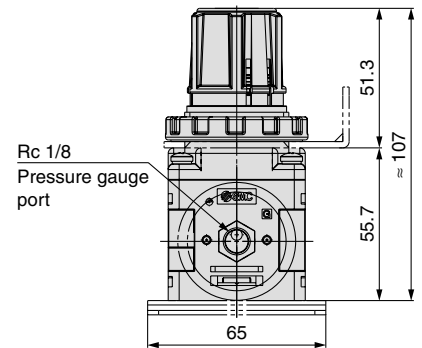
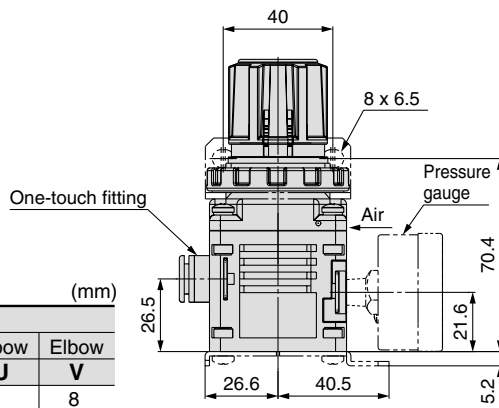
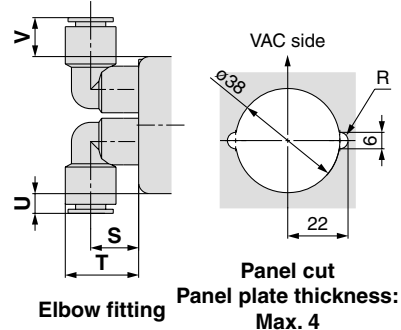
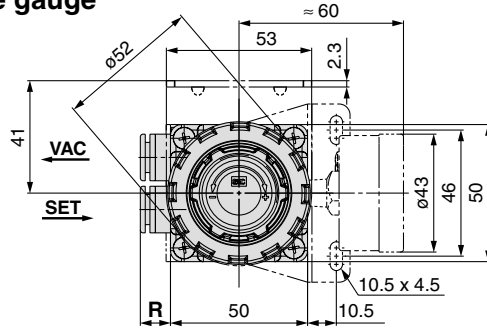

Fitting Part Dimensions

Fitting size	VAC/SET				
	Straight	Elbow	Elbow	Elbow	Elbow
	R	S	T	U	V
ø6	10.5	21	27.5	1	8
ø1/4"	10.5	21	27.5	1.5	8.5
ø8, ø5/16"	10.5	21	28.5	4	11
ø10, ø3/8"	11	21	30.5	7	14

IRV20A-□□□Z^N_A^P_B: With digital pressure switch

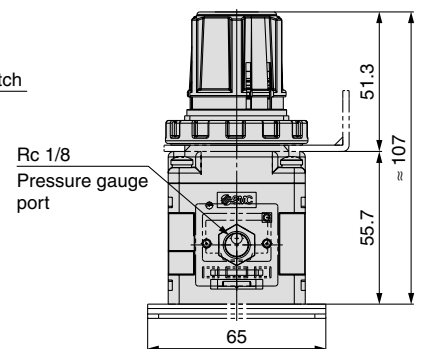
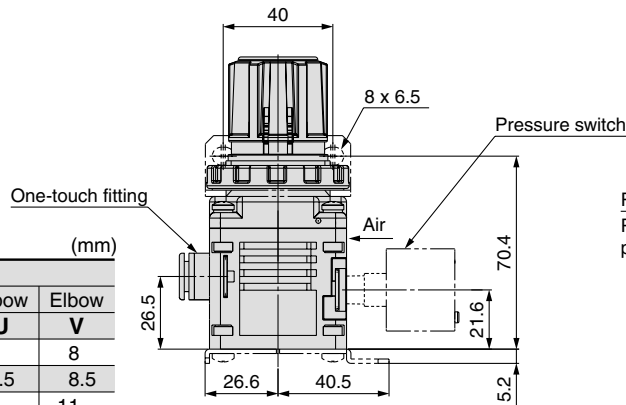
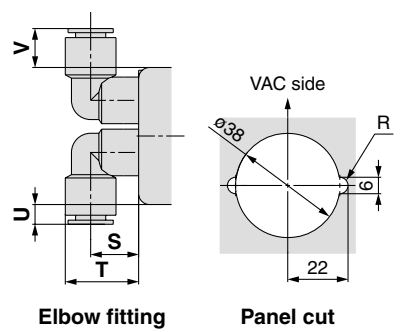
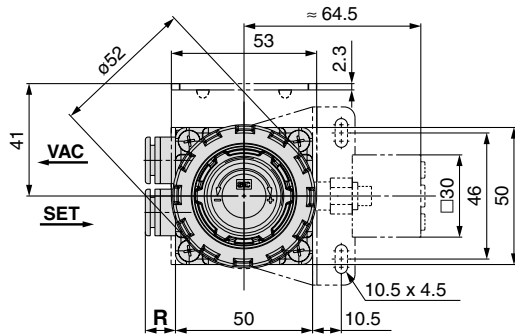

Fitting Part Dimensions

Fitting size	VAC/SET				
	Straight	Elbow	Elbow	Elbow	Elbow
	R	S	T	U	V
ø6	10.5	21	27.5	1	8
ø1/4"	10.5	21	27.5	1.5	8.5
ø8, ø5/16"	10.5	21	28.5	4	11
ø10, ø3/8"	11	21	30.5	7	14

Options

One-touch Fittings for Vacuum Regulator



One-touch fitting for IRV10(A)

VVQ1000-51A- C6

Fitting type		Fitting size	
Nil	Straight	Symbol	Size
L1	Elbow	C6	ø6
		C8	ø8
		N7	ø1/4"
		N9	ø5/16"

One-touch fitting for IRV20(A)

VVQ2000-51A- C6

Fitting type		Fitting size	
Nil	Straight	Symbol	Size
L1	Elbow	C6	ø6
		C8	ø8
		C10	ø10
		N7	ø1/4"
		N9	ø5/16"
		N11	ø3/8"

Plug Nut Assembly



Plug unused pressure gauge port(s).

P601010-11

Included Parts

No.	Description
1	Plug nut
2	O-ring

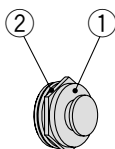

Gauge Nut Assembly



Used to connect the pressure gauge and pressure switch.

P601010-18

Included Parts

No.	Description
1	Gauge nut
2	O-ring

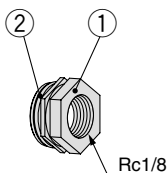

Bracket Assembly

For IRV10(A) P601010-17
For IRV20(A) P601020-17

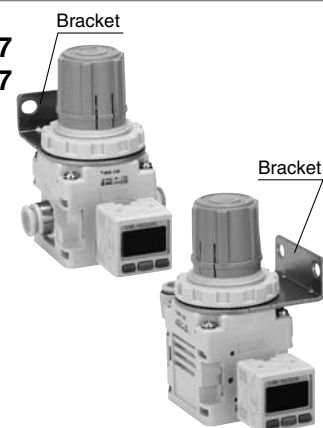

Bottom Bracket Assembly

For IRV10(A) P601010-14
For IRV20(A) P601020-14

Included Parts

No.	Description
1	Bottom bracket
2	Square nut x 4
3	Phillips screw x 4

Note) No. 1 to 3 are shipped together.

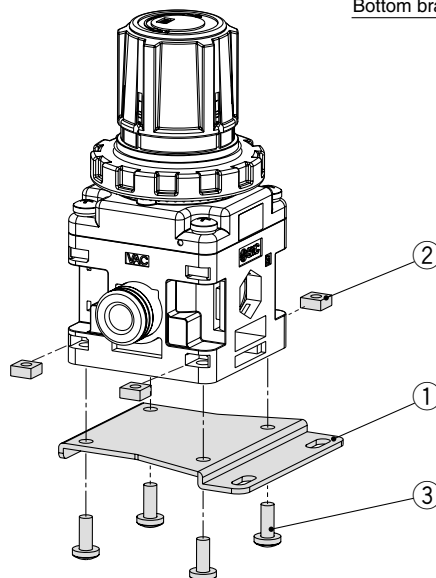
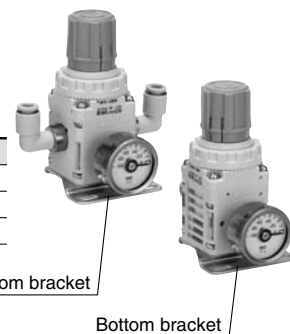

Phillips Screw Tightening Torque

For IRV10(A): M3	0.32 ±0.03 N·m
For IRV20(A): M4	0.76 ±0.05 N·m

Pressure Gauge for Vacuum

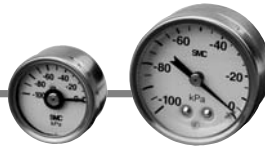

Part no.	GZ33-K-01	GZ43-K-01
Applicable model	IRV10	IRV20
Indicated pressure range	-100 to 0 kPa	
Unit display	kPa	
Scale range	180°	270°

GZ33-K-01

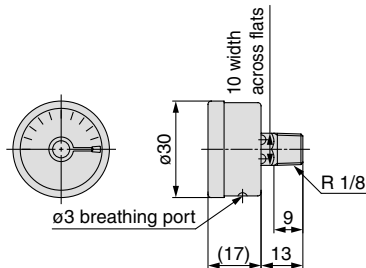

Pressure Gauge GZ33 Assembly P601010-12

Included Parts

No.	Description
1	Pressure gauge
2	Gauge nut
3	O-ring

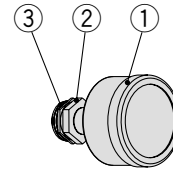

* 1 to 3 are assembled before shipment.

GZ43-K-01

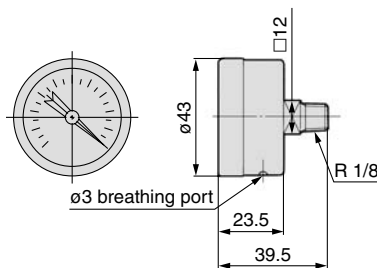

Pressure Gauge GZ43 Assembly P601020-12

Included Parts

No.	Description
1	Pressure gauge
2	Gauge nut
3	O-ring

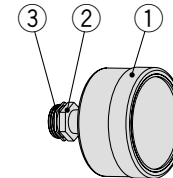

* 1 to 3 are assembled before shipment.

2-Color Display High Precision Digital Pressure Switch



Part No.

Part no.	Applicable model
ZSE30A-01-N-ML (NPN open collector 1 output)	IRV10 IRV20
ZSE30A-01-P-ML (PNP open collector 1 output)	
ZSE30A-01-A-ML (NPN open collector 2 outputs)	
ZSE30A-01-B-ML (PNP open collector 2 outputs)	

Specifications

Refer to SMC catalog CAT.ES100-70 for details.

Model	ZSE30A (Vacuum pressure)
Rated pressure range	0.0 to -101.0 kPa
Set pressure range	10.0 to -105.0 kPa
Proof pressure	500 kPa
Minimum unit setting	0.1 kPa
Applicable fluid	Air, Non-corrosive gas, Non-flammable gas
Power supply voltage	12 to 24 VDC ±10%, Ripple (p-p) 10% or less (With reverse connection protection)
Current consumption	40 mA or less
Switch output	NPN or PNP open collector 1 output, NPN or PNP open collector 2 outputs (Selectable)
Max. load current	80 mA
Max. applied voltage	28 V (With NPN output)
Residual voltage	1 V or less (With load current of 80 mA)
Response time	2.5 ms or less (With anti-chattering function: 20, 100, 500, 1000, 2000 ms selectable)
Short circuit protection	Yes

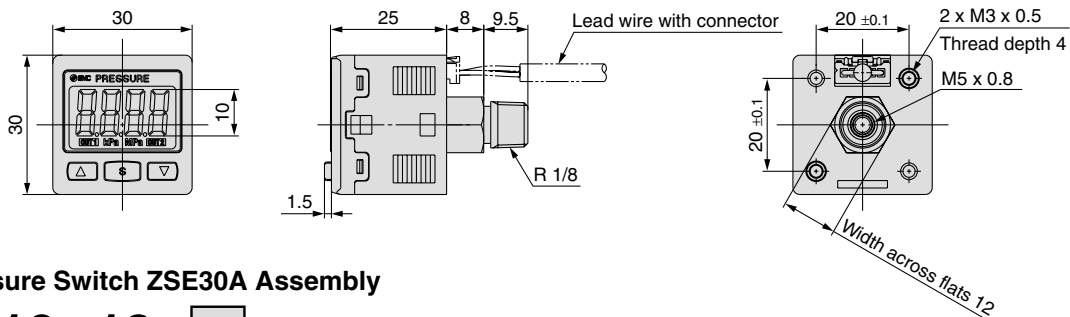

Digital Pressure Switch ZSE30A Assembly

P601010-13-□

Symbol	Digital pressure switch part no.	Digital pressure switch specifications
1	ZSE30A-01-N-ML	NPN open collector 1 output, Lead wire with connector (Length 2 m)
2	ZSE30A-01-P-ML	PNP open collector 1 output, Lead wire with connector (Length 2 m)
3	ZSE30A-01-A-ML	NPN open collector 2 outputs, Lead wire with connector (Length 2 m)
4	ZSE30A-01-B-ML	PNP open collector 2 outputs, Lead wire with connector (Length 2 m)

Included Parts

No.	Description
1	Digital pressure switch
2	Gauge nut
3	O-ring

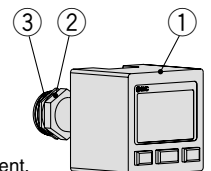

* 1 to 3 are assembled before shipment.

Vacuum Regulator Series IRV10/20

Made to Order



Please contact SMC regarding detailed dimensions, specifications, and lead times.

Integrated Digital Pressure Switch for Panel Mounting

X1

How to Order

Single sided connections

IRV 20 A - C08 - X1

Body size		Single sided connections		Digital pressure switch type ^{Note)}	
10	Max. flow 140 ℓ/min (ANR)	A	Single sided connections	X1	Integrated digital pressure switch for panel mounting
20	Max. flow 240 ℓ/min (ANR)				

Fittings		Connection tubing O.D.	
Nil	Straight	Symbol	Tubing O.D.
L	Elbow		

Symbol	Tubing O.D.	IRV10A	IRV20A
C06	Metric	●	●
C08		●	●
C10		—	●
N07	Inch	●	●
N09		●	●
N11		—	●

Symbol	Output specifications		Part no.
ZN	With digital pressure switch	NPN open collector 1 output	ZSE30A-C4H-N-MGD
ZP		PNP open collector 1 output	ZSE30A-C4H-P-MGD
ZA		NPN open collector 2 outputs	ZSE30A-C4H-A-MGD
ZB		PNP open collector 2 outputs	ZSE30A-C4H-B-MGD

Note) Gauge nut is included. Accessories are included in the same container.
* Refer to the digital pressure switch specifications on page 9.

Dimensions

IRV10A

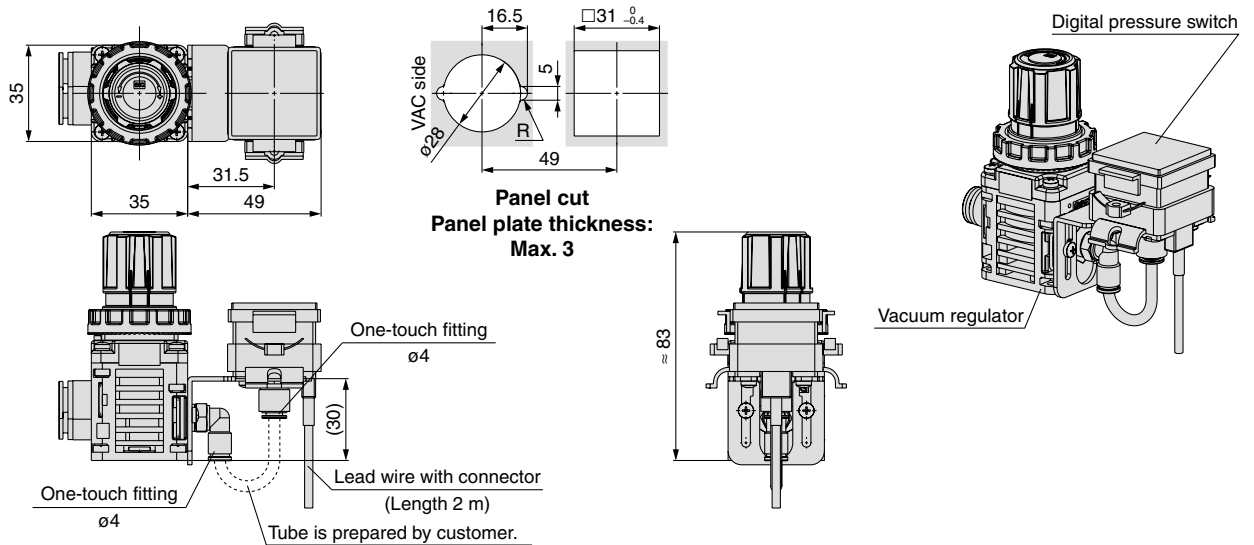

IRV20A

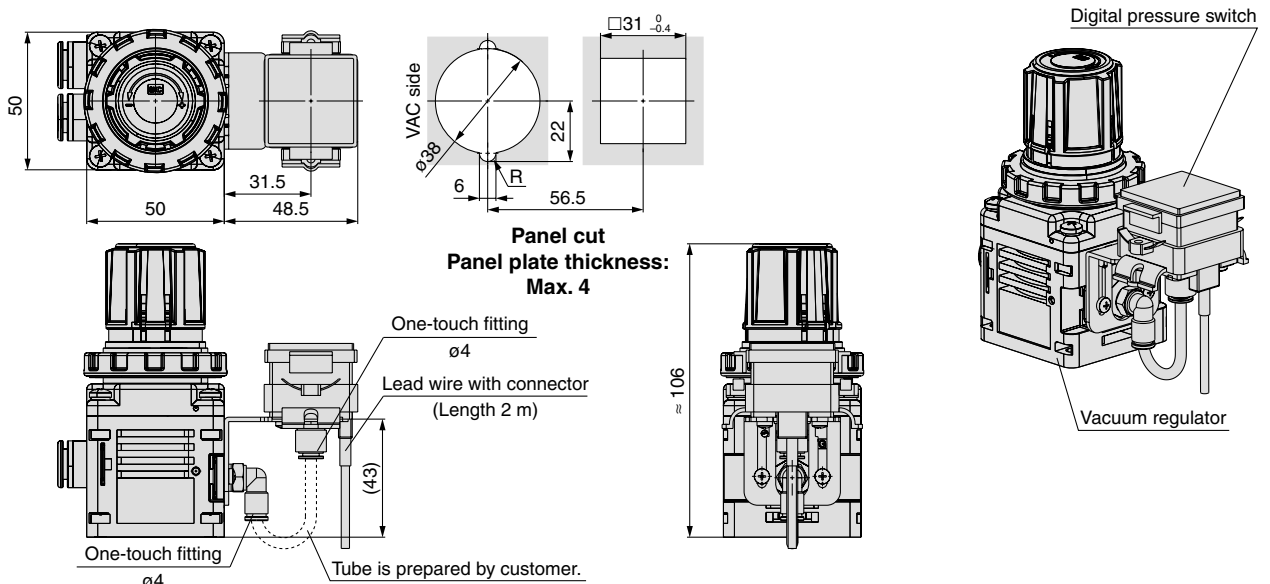



Series IRV10/20

Specific Product Precautions 1

Be sure to read this before handling.

Refer to back cover for Safety Instructions, "Handling Precautions for SMC Products" (M-E03-3) for Common Precautions.

Handling

Warning

1. When a system hazard can be expected due to a drop in vacuum pressure caused by power loss or vacuum pump trouble, install a safety circuit and configure the system so that it can avoid the danger.
2. When a system hazard can be expected with trouble with the vacuum regulator, install a safety circuit and configure the system so that it can avoid the danger.

Caution

1. When installing a pressure gauge or pressure switch on an existing regulator, be sure to reduce the set pressure to 0 (atmospheric pressure) before removing the plug.

1. Purchased with the pressure gauge or pressure switch
 - 1-1. Accessories

- Pressure gauge or pressure switch 1 pc.
- Gauge nut (with O-ring) 1 pc.

Note) Gauge nut is mounted to the pressure gauge or pressure switch.

- Plug nut (with O-ring) 1 pc.
- Clip 2 pcs.

Note) One clip is included for single sided connections. Plug nut is not included.

Pressure gauge

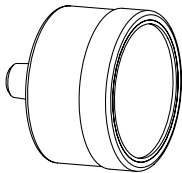

Pressure switch

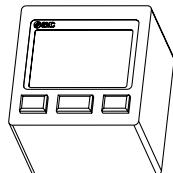

Gauge nut



Plug nut



Clip



- 1-2. Mounting of the pressure gauge or pressure switch

- 1) Confirm the direction of VAC side and SET side. Insert the pressure gauge to the gauge port sufficiently (until the gauge nut of the pressure gauge is level with the product surface.) Insert the pressure gauge to the end on the opposite side of the connecting port for single sided connections.

- 2) Insert the clip from the left side (viewed from the pressure gauge side, as shown in the drawing) until the top of the clip is level with the product surface. This completes the mounting procedure for single sided connections.

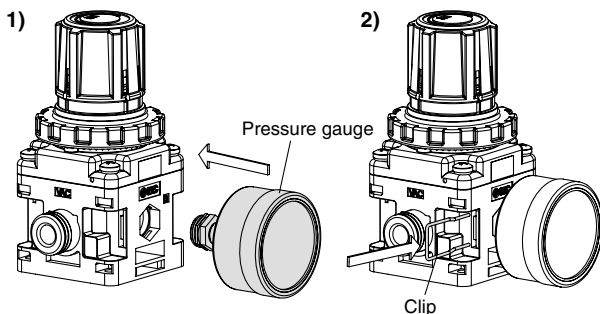

Caution

- 3) Insert the plug nut to the gauge port on the opposite side of the pressure gauge until the top of the plug nut is level with the product surface.
- 4) Insert the clip from the left side (viewed from the plug nut side) to the end in the same way as 2).

3) 4)

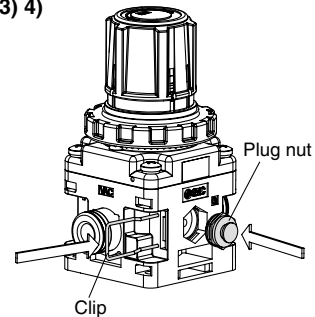

Note) To remove the pressure gauge or pressure switch, remove the clip, then remove the pressure gauge or pressure switch straight out. Do not apply torque, as the body is made of resin.

2. Do not remove the body screw while the vacuum pressure is applied.

3. Before removing the valve guide for inspection, reduce the set pressure to 0 (atmospheric pressure) and also shut down the vacuum pump pressure completely.

4. For ease of replacement, One-touch fittings are installed as the cassette type. One-touch fittings are retained with clips inserted from the directions illustrated below. Remove the clips with a flat head screwdriver to replace the One-touch fittings. (Refer to "Procedure to remove the clip.") When installing, insert each One-touch fitting deeply to the end and reinsert the clip to the specified position.

Note 1) Before replacement, confirm VAC/SET pressure is not applied and start operation after the internal pressure becomes atmospheric pressure. Operation with VAC/SET pressure is dangerous.

Note 2) To remove the clip, hold the clip with your fingers, then slowly pull out the clip. Do not pull out the clip by force. Otherwise, the clip may spring out and it is dangerous.

Note 3) Insert the clip to the end after confirming the replacement parts are inserted to the end. The clip may spring out if it is not inserted sufficiently.

Note 4) Hold the fitting in your hand when inserting the tube to elbow type One-touch fitting. Insertion of the tube without holding the fitting in your hand will apply excess force to blocks or One-touch fitting, which may lead to air leakage or breakage.

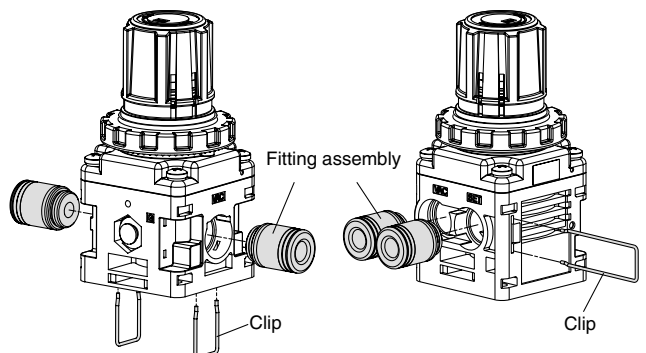



Series IRV10/20

Specific Product Precautions 2

Be sure to read this before handling.

Refer to back cover for Safety Instructions, "Handling Precautions for SMC Products" (M-E03-3) for Common Precautions.

Handling

⚠ Caution

Procedure to remove the clip

Apply the tip of a flat head screwdriver to the inclined part where the clip is inserted. Lift the clip by moving the screwdriver as illustrated below.

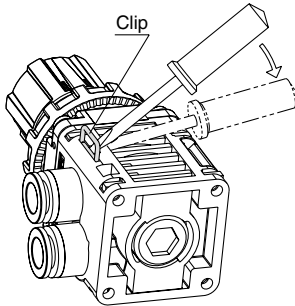

Insert the tip of the screwdriver to the root of the clip.

⚠ Warning

1. Observe the proper screw tightening torque.

If torque is exceeded, damage to the mounting screw or main body may occur. Also, if the screws are not tightened enough, the screws may come loose during operation.

Tightening torque of Phillips screw for mounting bottom bracket

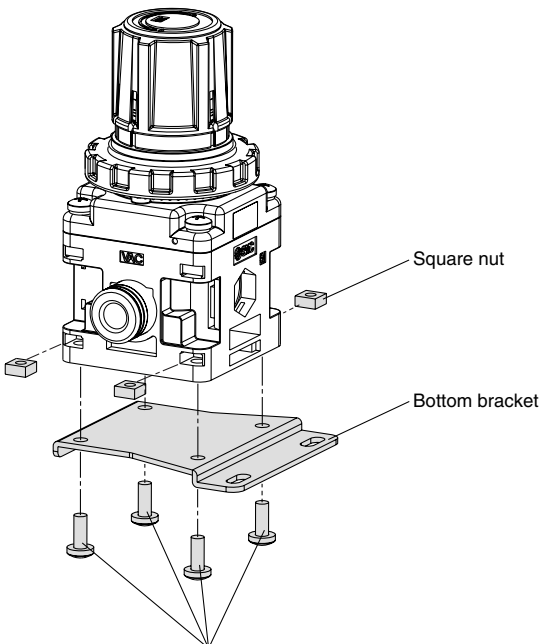

Phillips Screw Tightening Torque

For IRV10(A): M3	0.32 ±0.03 N·m
For IRV20(A): M4	0.76 ±0.05 N·m

Operating Environment

⚠ Warning

1. Do not use in an atmosphere having corrosive gases, chemicals, sea water, water, water steam, or where there is direct contact with any of these.
2. Do not use in locations influenced by vibrations or impacts.
3. This vacuum regulator always uses atmospheric air, therefore, do not use in dusty environments.
4. In locations which receive direct sunlight, provide a protective cover, etc.
5. In locations near heat sources, block off any radiated heat.

Vacuum Supply

⚠ Caution

1. This vacuum regulator is not to be used for adjusting vacuum pump pressures.
2. Note that an ejector's flow rate is smaller than that of the vacuum regulator, and therefore, it is not suitable as a "vacuum supply".

Air Supply

⚠ Caution

1. These products are designed for use with air. Please contact SMC if any other fluid will be used.
2. Do not use air which includes chemicals, synthetic oils containing organic solvents, salt, or corrosive gases, etc., as this can cause malfunction.



Series IRV10/20

Specific Product Precautions 3

Be sure to read this before handling.

Refer to back cover for Safety Instructions, "Handling Precautions for SMC Products" (M-E03-3) for Common Precautions.

Precautions

⚠ Caution

1. Connect piping to the port with "VAC" indication for connection to the vacuum pump.
2. To adjust the pressure, turn the knob to the right (clockwise) for changing "atmospheric pressure to vacuum pressure" and to the left (counterclockwise) for changing "vacuum pressure to atmospheric pressure".
3. When adjusting pressure, do not touch the lateral hole (atmospheric intake hole) of the body.
4. When locking the knob after setting the pressure, press down the knob until the orange band is hidden and a click is heard. On the other hand, when unlocking the knob, pull it up until the orange band is visible and a click is heard.
5. When the vacuum pump capacity is relatively small or when the inside diameter of the piping is small, a change in the set pressure (the pressure difference between the non-flow and flow conditions) may be large. In this case, change the vacuum pump or the inside diameter of the piping. When changing the vacuum pump is not possible, add a capacity tank (the capacity depends on the operating conditions) to the VAC side.
6. The pressure response time after opening and closing of valves (such as solenoid valves) is influenced in large and small measures by the internal capacity (includes piping capacity) of the set side. Since the vacuum pump capacity also affects the response time, consider all these points before operations.
7. When using a pressure gauge upside down like Fig. 1, it may result in a shifting of the zero point reading. Make sure to use it in the direction like Fig. 2. Gravity will affect the zero point of the gauge which is why it needs to be positioned properly.

IRV10

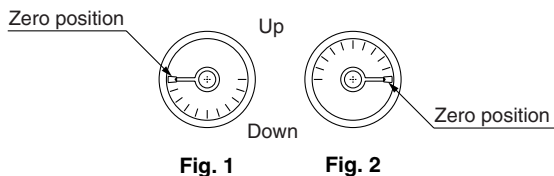

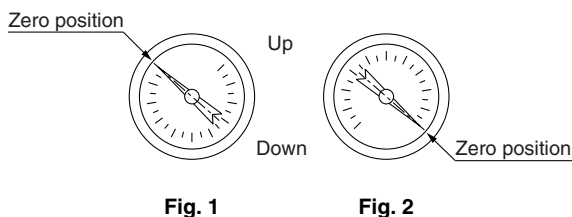

IRV20



Safety Instructions

These safety instructions are intended to prevent hazardous situations and/or equipment damage. These instructions indicate the level of potential hazard with the labels of “**Caution**,” “**Warning**” or “**Danger**.” They are all important notes for safety and must be followed in addition to International Standards (ISO/IEC)*1), and other safety regulations.

 **Caution:** **Caution** indicates a hazard with a low level of risk which, if not avoided, could result in minor or moderate injury.

 **Warning:** **Warning** indicates a hazard with a medium level of risk which, if not avoided, could result in death or serious injury.

 **Danger :** **Danger** indicates a hazard with a high level of risk which, if not avoided, will result in death or serious injury.

*1) ISO 4414: Pneumatic fluid power – General rules relating to systems.
ISO 4413: Hydraulic fluid power – General rules relating to systems.
IEC 60204-1: Safety of machinery – Electrical equipment of machines.
(Part 1: General requirements)
ISO 10218-1: Manipulating industrial robots - Safety.
etc.

Warning

1. The compatibility of the product is the responsibility of the person who designs the equipment or decides its specifications.

Since the product specified here is used under various operating conditions, its compatibility with specific equipment must be decided by the person who designs the equipment or decides its specifications based on necessary analysis and test results. The expected performance and safety assurance of the equipment will be the responsibility of the person who has determined its compatibility with the product. This person should also continuously review all specifications of the product referring to its latest catalog information, with a view to giving due consideration to any possibility of equipment failure when configuring the equipment.

2. Only personnel with appropriate training should operate machinery and equipment.

The product specified here may become unsafe if handled incorrectly. The assembly, operation and maintenance of machines or equipment including our products must be performed by an operator who is appropriately trained and experienced.

3. Do not service or attempt to remove product and machinery/equipment until safety is confirmed.

1. The inspection and maintenance of machinery/equipment should only be performed after measures to prevent falling or runaway of the driven objects have been confirmed.
2. When the product is to be removed, confirm that the safety measures as mentioned above are implemented and the power from any appropriate source is cut, and read and understand the specific product precautions of all relevant products carefully.
3. Before machinery/equipment is restarted, take measures to prevent unexpected operation and malfunction.

4. Contact SMC beforehand and take special consideration of safety measures if the product is to be used in any of the following conditions.

1. Conditions and environments outside of the given specifications, or use outdoors or in a place exposed to direct sunlight.
2. Installation on equipment in conjunction with atomic energy, railways, air navigation, space, shipping, vehicles, military, medical treatment, combustion and recreation, or equipment in contact with food and beverages, emergency stop circuits, clutch and brake circuits in press applications, safety equipment or other applications unsuitable for the standard specifications described in the product catalog.
3. An application which could have negative effects on people, property, or animals requiring special safety analysis.
4. Use in an interlock circuit, which requires the provision of double interlock for possible failure by using a mechanical protective function, and periodical checks to confirm proper operation.

Caution

1. The product is provided for use in manufacturing industries.

The product herein described is basically provided for peaceful use in manufacturing industries.
If considering using the product in other industries, consult SMC beforehand and exchange specifications or a contract if necessary.
If anything is unclear, contact your nearest sales branch.

Limited warranty and Disclaimer/ Compliance Requirements

The product used is subject to the following “Limited warranty and Disclaimer” and “Compliance Requirements”.

Read and accept them before using the product.

Limited warranty and Disclaimer

1. The warranty period of the product is 1 year in service or 1.5 years after the product is delivered.*2)
Also, the product may have specified durability, running distance or replacement parts. Please consult your nearest sales branch.
2. For any failure or damage reported within the warranty period which is clearly our responsibility, a replacement product or necessary parts will be provided.
This limited warranty applies only to our product independently, and not to any other damage incurred due to the failure of the product.
3. Prior to using SMC products, please read and understand the warranty terms and disclaimers noted in the specified catalog for the particular products.

*2) Vacuum pads are excluded from this 1 year warranty.

A vacuum pad is a consumable part, so it is warranted for a year after it is delivered.
Also, even within the warranty period, the wear of a product due to the use of the vacuum pad or failure due to the deterioration of rubber material are not covered by the limited warranty.

Compliance Requirements

1. The use of SMC products with production equipment for the manufacture of weapons of mass destruction (WMD) or any other weapon is strictly prohibited.
2. The exports of SMC products or technology from one country to another are governed by the relevant security laws and regulations of the countries involved in the transaction. Prior to the shipment of a SMC product to another country, assure that all local rules governing that export are known and followed.

Revision history

Edition B * Addition of gauge nut assembly part number

OZ

Safety Instructions

Be sure to read “Handling Precautions for SMC Products” (M-E03-3) before using.

SMC Corporation

Akihabara UDX 15F,
4-14-1, Sotokanda, Chiyoda-ku, Tokyo 101-0021, JAPAN
Phone: 03-5207-8249 Fax: 03-5298-5362
URL <http://www.smcworld.com>
© 2010 SMC Corporation All Rights Reserved

Specifications are subject to change without prior notice
and any obligation on the part of the manufacturer.

D-DN

1st printing MX printing OZ 12450SZ Printed in Japan.