



Clean Gas Filter

Cartridge Type/Disposable Type



Disposable type
SFC10

Cartridge type
SFA10
SFA20
SFA30

Disposable type
SFB30

Cartridge type
SFB10
SFB20

Series **SF**

SMC Clean Gas Filter (SF series)

■ Integrated production in a clean environment

Under a clean environment, cleaning, assembly, inspection and antistatic double packaging processes are done in an integrated production system.

Assembly environment
<ul style="list-style-type: none"> • Clean room: M5.5 (ISO class 7)* • Clean booth: M3.5 (ISO class 5)*

* Fed.std.209E () : based on ISO 14644-1

■ High precision filtration

0.01 μ m filtration (filtering efficiency of 99.99%) is realized with the PTFE membrane cartridge element. (Clean gas strainer: Nominal filtration of 120 μ m)

■ Can be used under different environments

This filter can be used under different environments with chemical resistant and heat resistant materials (Refer to specifications for each series.).

Application Examples

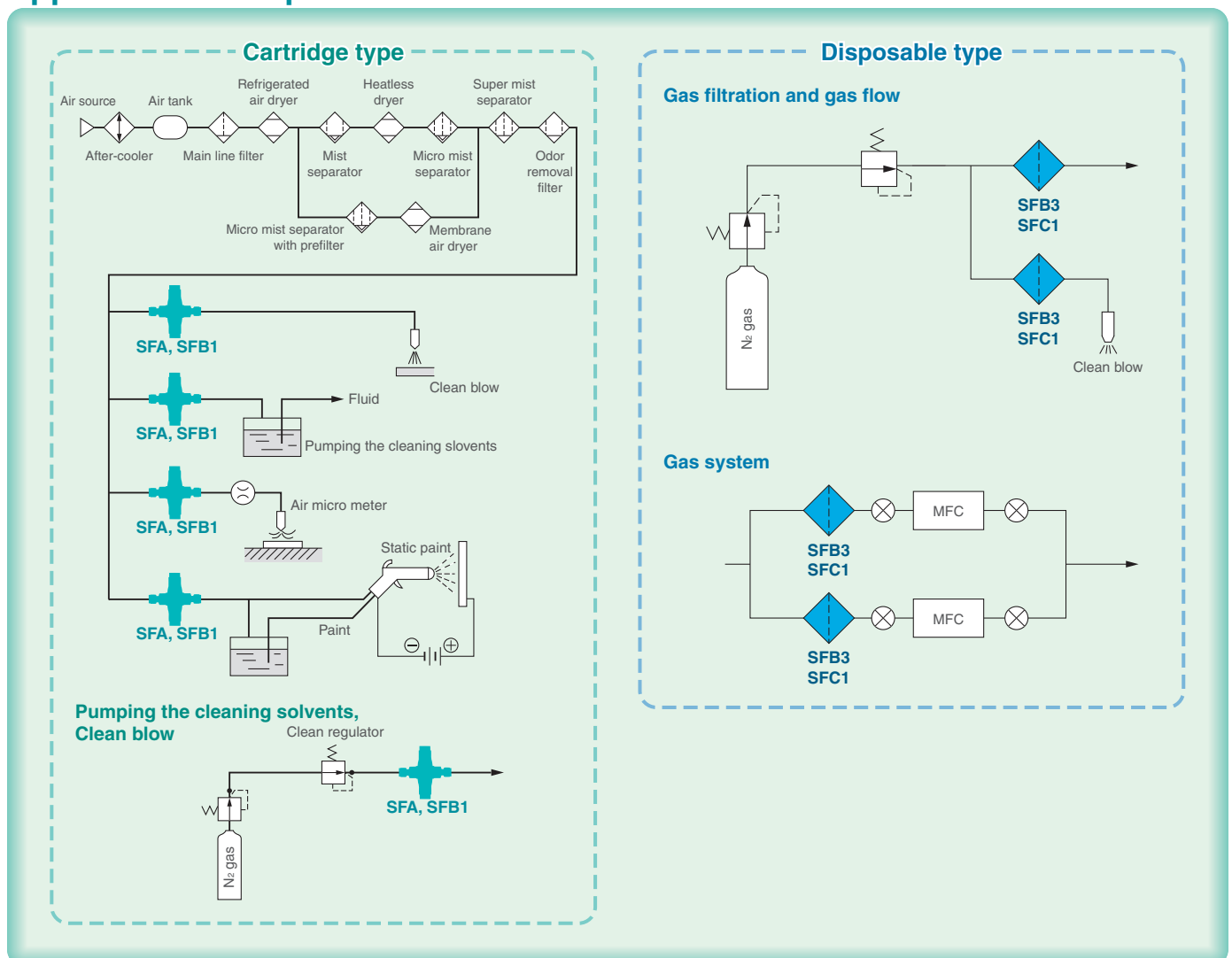

	Series	Filtration	Flow rate ℓ/min (ANR) (Max. flow rate at 0.7 MPa)	Pressure MPa	Temperature °C	Replacement of element	Page
Cartridge type	 <p>Disc style</p>		0.01 μm	0.99	5 to 80	Replaceable	P. 2
	SFA10□	26					
	SFA20□	70					
	SFA30□	140					
Cartridge type	 <p>Straight style</p>		120 μm	0.99	5 to 80	Replaceable	P. 4
	SFB10□	45					
Disposable type	 <p>Straight style</p>		0.01 μm	0.99	5 to 120	Nonreplaceable	P. 7
	SFB30□	45					
	 <p>Multiple disc style</p>		SFC10□	300	0.99		P. 9
Made to Order		<ul style="list-style-type: none"> • Case/Cover material: Aluminum alloy (SFB100) • Strainer with other filtrations 1, 2, 5, 10, 20, 40, 70, 100 μm (SFB200) 					P. 11
Specific Product Precautions							Back page 1

Model Selection

Determine the model by using the following procedures involving the inlet pressure and the maximum flow rate.

Example) Inlet pressure: 0.6 MPa

Maximum flow rate: 200 l/min (ANR)

1. Determine intersection A for the inlet pressure and the maximum flow rate by using the maximum flow rate graph.
2. If the obtained intersection A is above the maximum flow rate line, SFC10□ is selected.

Note) Please be sure to select a model with a maximum flow rate line which is above the obtained intersection A.
If the obtained intersection A is below the maximum flow rate line, overflow will occur. This will cause a nonconformance in which the specification will not be satisfied.

Maximum Flow Rate Lines

Clean Gas Filter

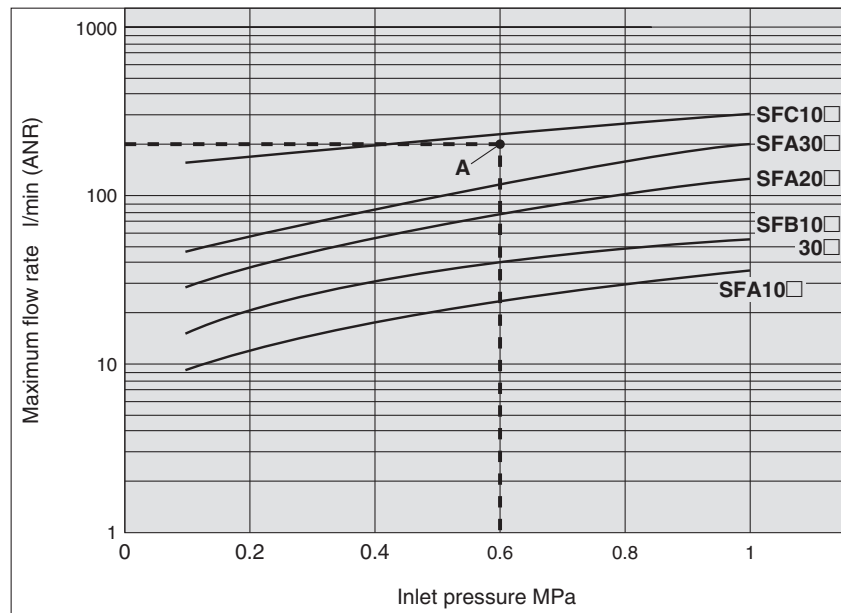

Clean Gas Strainer

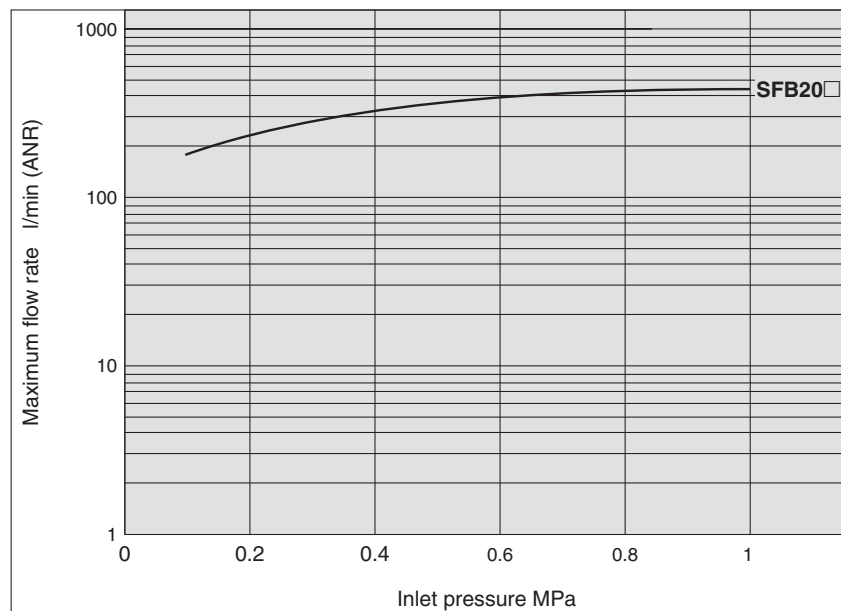

Clean Gas Filter: Cartridge Type/Disc Type **SFA100/200/300 Series**

RoHS

Precision filtration for compressed air, nitrogen, used in the electronic industry, etc.

PTFE membrane element is made into a cartridge. (Filtration 0.01 μm (Filtering efficiency 99.99 %))

Made into a cartridge by polyester holder and fluororubber (FKM) gasket.

Elements are replaceable.



How to Order

SFA 10 0 - 02

Clean gas filter
Cartridge type
(Disc type)

Port size

Symbol	Port size
02	Rc, NPT, TSJ, UOJ 1/4

Model size

Symbol	Rated flow rare l/min(ANR)
10	Up to 26
20	Up to 70
30	Up to 140

Connection

Symbol	Connection (IN, OUT)
0	Rc
1	NPT
2	TSJ
3	UOJ

Model

Model	Rated flow rate l/min (ANR) ^{Note 1)}	Connection	Filtration area cm ²	Element part no. ^{Note 2)}	Weight kg
SFA100-02	26	Rc 1/4 (Female thread)	13.85	ED001S-X10V	0.34
SFA101-02		NPT 1/4 (Female thread)			
SFA200-02	70	Rc 1/4 (Female thread)	33.18	ED101S-X10V	0.44
SFA201-02		NPT 1/4 (Female thread)			
SFA300-02	140	Rc 1/4 (Female thread)	56.75	ED201S-X10V	0.66
SFA301-02		NPT 1/4 (Female thread)			
SFA102-02	26	TSJ 1/4 Tube Swage Joint	13.85	ED001S-X10V	0.38
SFA202-02	70		33.18	ED101S-X10V	0.49
SFA302-02	140		56.75	ED201S-X10V	0.70
SFA103-02	26	UOJ 1/4 Union O-ring Joint	13.85	ED001S-X10V	0.42
SFA203-02	70		33.18	ED101S-X10V	0.53
SFA303-02	140		56.75	ED201S-X10V	0.75

Note 1) Inlet pressure 0.7 MPa, at pressure drop 0.02 MPa

Note 2) Element part numbers include numbers 3 to 7 in the construction figure. (Refer to page 2-1.)

Series SFA100/200/300

Specifications

Operating fluid		Air, Nitrogen
Operating pressure <small>Note 1)</small>		Max. 1.0 MPa, Vacuum 1.3×10^{-6} kPa
Operating temperature		5 to 80 °C
Element proof differential pressure		Max. 0.1 MPa
Element reverse differential pressure		Max. 0.05 MPa
Filtration <small>Note 2)</small>		0.01 μm (Filtering efficiency 99.99%)
Main material	Case	Stainless steel 316 (Interior/Exterior: Electrolytic polishing)
	Filter medium	PTFE membrane
	Seal	Fluoro rubber (FKM)
Packaging		Antistatic sealed double package

Note 1) The maximum operating pressure is 0.99 MPa since this product does not conform to the High Pressure Gas Safety Law. Use under conditions where pressure fluctuations (pulsations) exceeding 0.1 MPa do not occur.

Note 2) Based on SMC's measuring conditions.

Construction

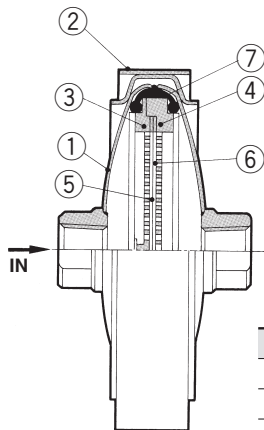

No.	Description	Material	Note
1	Case	Stainless steel 316	Electrolytic polishing (Interior/Exterior)
2	V-clamp	Stainless steel 304	—
3	Holder 1	Polyester	Cartridge element
4	Holder 2		
5	Filter medium	PTFE	
6	Seal	FKM	
7	V-seal		

Flow Characteristics Fluid: Compressed air Inlet temperature: 20 °C

SFA10

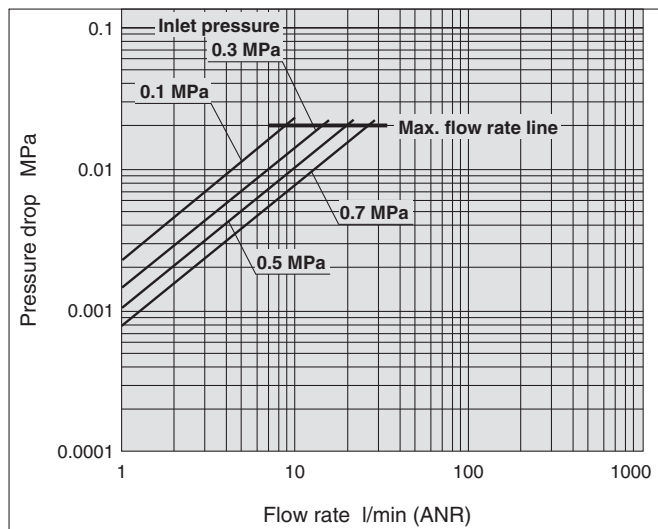

Dimensions

SFA100/101, SFA200/201, SFA300/301

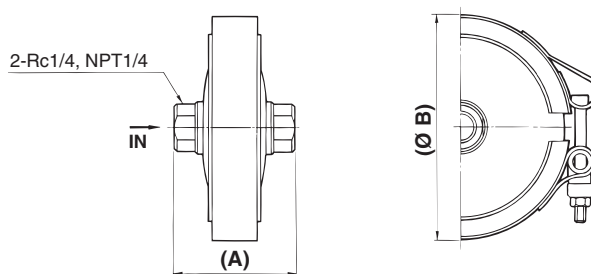

Model	Connection	(A)	(Ø B)
SFA100-02	Rc1/4	46	76
SFA101-02	NPT1/4	46	76
SFA200-02	Rc1/4	51	96
SFA201-02	NPT1/4	51	96
SFA300-02	Rc1/4	59	120
SFA301-02	NPT1/4	59	120

(): Reference dimensions

SFA20

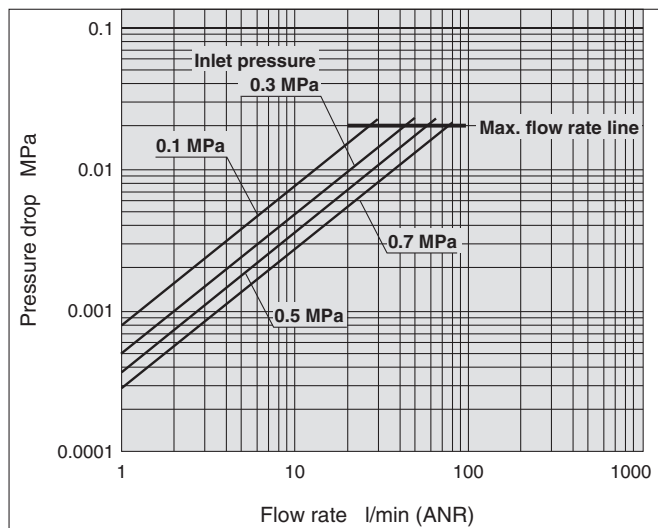

SFA102, SFA202, SFA302

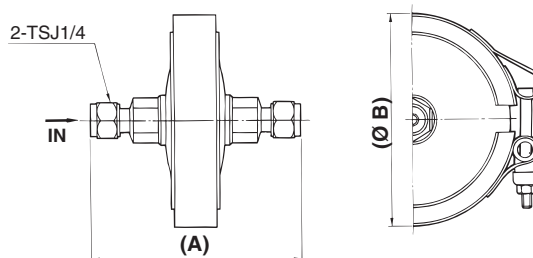

Model	Connection	(A)	(Ø B)
SFA102-02	TSJ1/4 (Tube swage joint)	89	76
SFA202-02		93	96
SFA302-02		101	120

(): Reference dimensions

SFA30

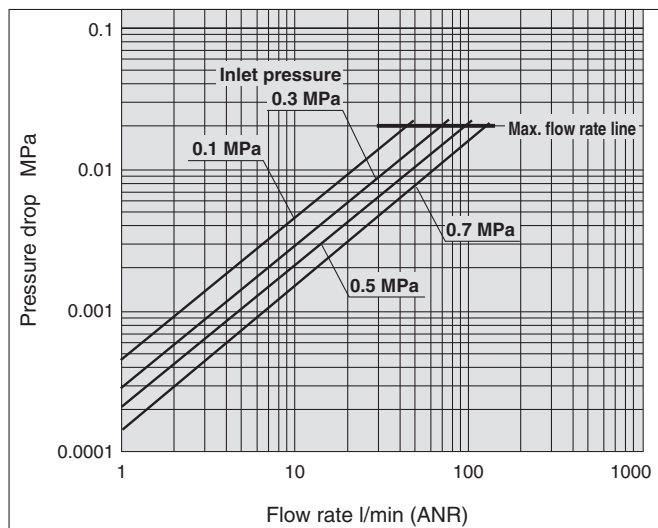

SFA103, SFA203, SFA303

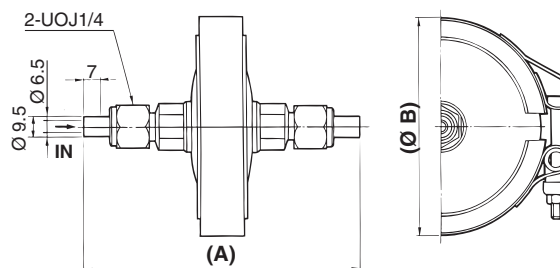

Model	Connection	(A)	(Ø B)
SFA103-02	UOJ1/4 (Union O-ring joint)	117	76
SFA203-02		122	96
SFA303-02		130	120

(): Reference dimensions

Clean Gas Filter: Cartridge Type/Straight Type **SFB100 Series**

RoHS

Precision filtration for compressed air, nitrogen, used in the electronic industry, etc.

PTFE membrane element is made into a cartridge. (Filtration 0.01 μm (Filtering efficiency 99.99 %))

Made into a cartridge by fluoropolymer holder and fluororubber (FKM) gasket.

Elements are replaceable.

Bracket is included as a standard.



How to Order

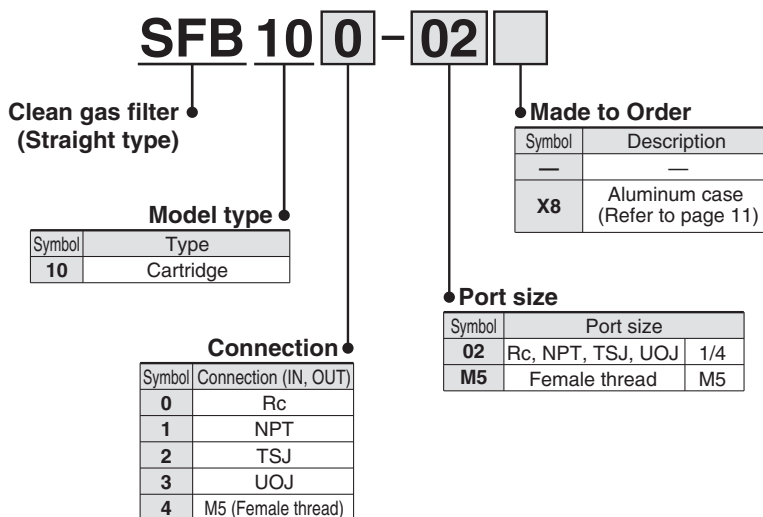

Specifications

Fluid	Air, Nitrogen	
Operating pressure ^{Note 1)}	Max. 0.99 MPa, Vacuum 1.3 x 10 ⁻⁶ kPa	
Operating temperature	5 to 80°C	
Element proof differential pressure	Max. 0.5 MPa	
Element reverse differential pressure	Max. 0.07 MPa	
Filtration ^{Note 2)}	0.01 μm (Filtering efficiency 99.99 %)	
Main material	Case/Cover	Stainless steel 316 (Interior/Exterior: Electrolytic polishing)
	Filter medium	PTFE membrane
	Seal	Fluororubber (FKM)
Packaging	Antistatic sealed double package	

Note 1) The maximum operating pressure is 0.99 MPa since this product does not conform to the High Pressure Gas Safety Law. Use under conditions where pressure fluctuations (pulsations) exceeding 0.1 MPa do not occur.

Note 2) Based on SMC's measuring conditions.

Model

Model	Rated flow rate L/min (ANR) ^{Note)}	Connection	Filtration area cm ²	Element part no.	Weight kg
SFB100-02	45	Rc 1/4 (Female thread)	10	ED301S-X10V (Including O-rings)	0.15
SFB101-02		NPT 1/4 (Female thread)			
SFB102-02		TSJ 1/4			
SFB103-02		UOJ 1/4			
SFB104-M5		M5 (Female thread)			

Note) Inlet pressure 0.7 MPa, at pressure drop 0.02 MPa

Clean Gas Strainer: Cartridge Type/Straight Type **SFB200 Series**

Cartridge made of stainless steel 316 sintered metallic element (Nominal filtration: 120 μm)

Clean gas strainers made of an element (120 μm, stainless steel 316 sintered metal) to protect regulators and vacuum regulators are also available.

Elements are replaceable.
Bracket is included as a standard.



SFB200-02

How to Order

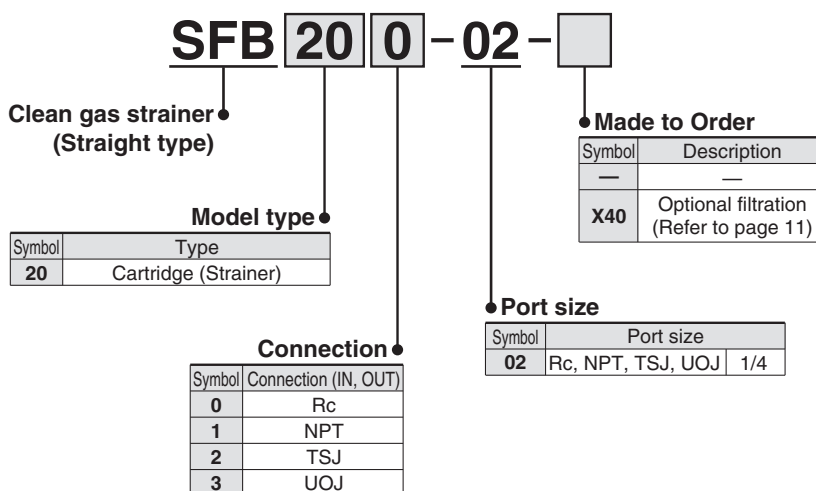

Specifications

Fluid	Air, Nitrogen	
Operating pressure	Max. 0.99 MPa, Vacuum 1.3 x 10 ⁻⁶ kPa	
Operating temperature <small>Note)</small>	5 to 80 °C	
Element proof differential pressure	Max. 1.0 MPa	
Element reverse differential pressure	Max. 1.0 MPa	
Nominal filtration *	120 μm	
Main material	Case/Cover	Stainless steel 316 (Interior/Exterior: Electrolytic polishing)
	Seal	Fluororubber (FKM)
	Filter medium	Stainless steel 316 sintered metal
Packaging	Antistatic sealed double package	

Note) The maximum operating pressure is 0.99 MPa since this product does not conform to the High Pressure Gas Safety Law.

* Options other than standard filtration are available as made to order. For details, refer to page 11.

Model

Model	Rated flow rate l/min (ANR) <small>Note)</small>	Connection	Filtration area cm ²	Element part no. (Including O-rings)	Weight kg
SFB200-02	400	Rc 1/4 (Female thread)	10	ES001S-120V	0.16
SFB201-02		NPT 1/4 (Female thread)			
SFB202-02		TSJ 1/4			
SFB203-02		UOJ 1/4			

Note) Inlet pressure 0.7 MPa, at pressure drop 0.02 MPa

Series SFB100/200

Construction

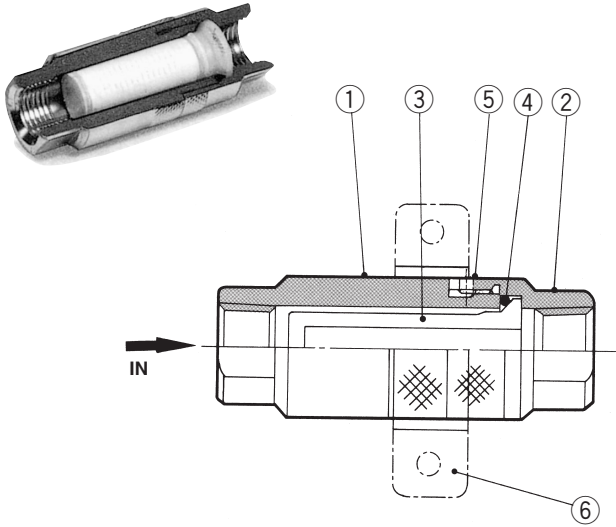

No.	Description	Material	Note
1	Case	Stainless steel 316	Electrolytic polishing (Interior/Exterior)
2	Cover		
3	Clean gas filter	PTFE membrane	For SFB10□
	Clean gas strainer	Stainless steel 316 sintered metal	For SFB20□
4	O-ring	FKM	—
5	Hexagon socket head screw	Stainless steel 304	M3
6	Bracket		—

Flow Characteristics Fluid: Compressed air Inlet temperature: 20°C

SFB104-M5

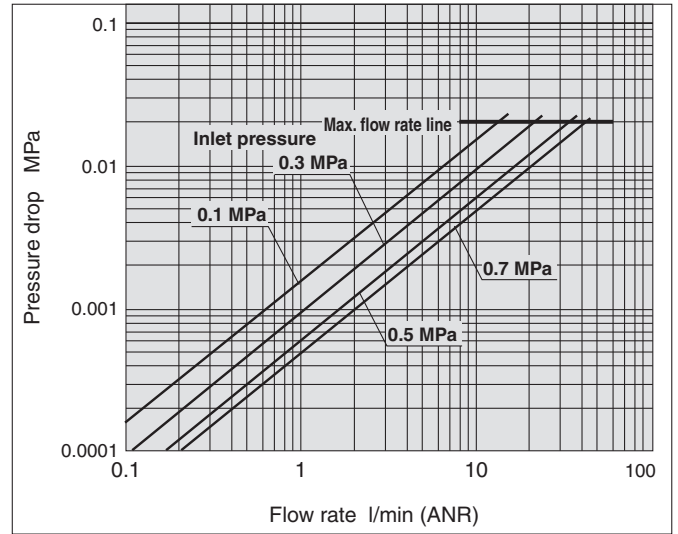

SFB10□-02

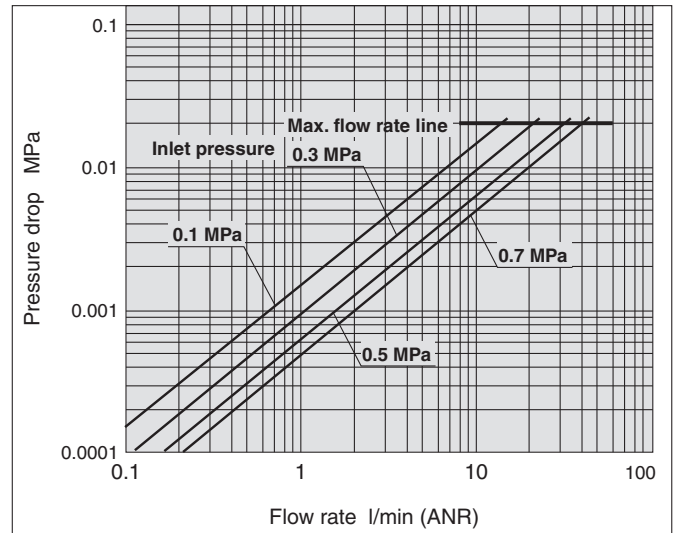

SFB20□-02

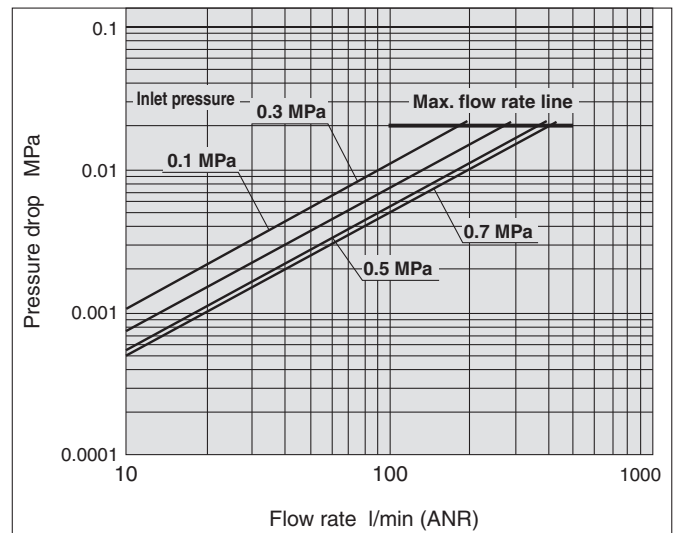

Dimensions

SFB100/200: Rc1/4

SFB101/201: NPT1/4

SFB104: M5

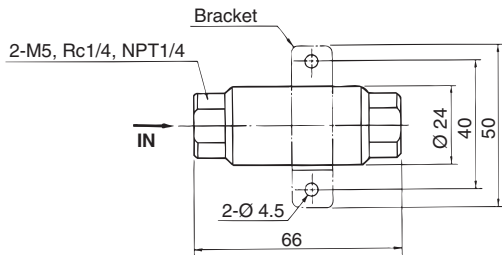

Model	Connection
SFB100-02, 200-02	Rc1/4
SFB101-02, 201-02	NPT1/4
SFB104-M5	M5

SFB102-02, SFB202-02: TSJ1/4 (Tube swage joint)

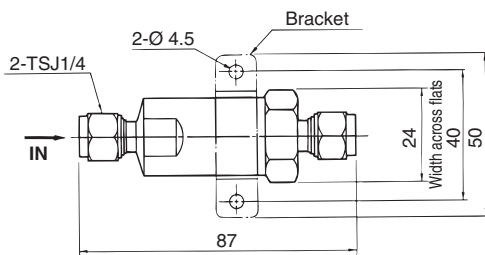

SFB103-02, SFB203-02: UOJ1/4 (Union O-ring joint)

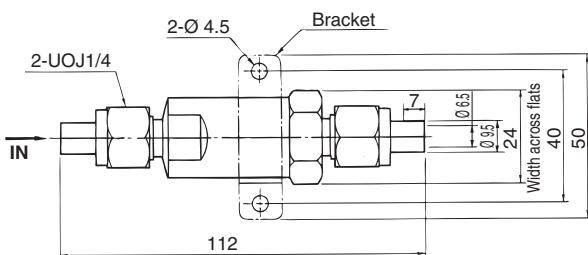

Clean Gas Filter: Disposable Type/Straight Type **SFB300 Series**



Precision filtration for compressed air, nitrogen, used in the semiconductor process

PTFE membrane with high reliability

Filtration 0.01 μm
(Filtering efficiency 99.99 %)

Bracket is included as a standard.



How to Order

SFB 30 0 - 02

Clean gas filter
(Straight type)

Port size

Symbol	Port size
02	Rc, NPT, TSJ, UOJ 1/4

Model type

Symbol	Type
30	Disposable (Narrow size)
31	Disposable (Long size)

Connection

Symbol	Connection (IN, OUT)
0	Rc
2	TSJ
5	URJ

* SFB31: Only 5 is selectable.

Model

Model	Rated flow rate l/min (ANR) ^{Note)}	Connection	Filtration area cm ²	Weight kg
SFB300-02	45	Rc 1/4 (Female thread)	10	0.14
SFB302-02		TSJ 1/4		0.15
SFB305-02		URJ 1/4		0.14
SFB315-02		URJ 1/4		0.15

Note) Inlet pressure 0.7 MPa, at pressure drop 0.02 MPa

Clean Gas Filter: Disposable Type/Straight Style **Series SFB300**

Specifications

Operating fluid		Air, Nitrogen
Operating pressure <small>Note 1)</small>		Max. 0.99 MPa, Vacuum 1.3×10^{-6} kPa
Operating temperature		5 to 120 °C
Element proof differential pressure		Max. 0.5 MPa
Element reverse differential pressure		Max. 0.07 MPa
Filtration <small>Note 2)</small>		0.01 μm (Filtering efficiency 99.99 %)
Helium leak volume		4.0×10^{-9} Pa·m ³ /sec or less
Main material	Case/Cover	Stainless steel 316 (Interior/Exterior: Electrolytic polishing)
	Filter medium	PTFE membrane
	O-ring	Stainless steel 304

Note 1) The maximum operating pressure is 0.99 MPa since this product does not conform to the High Pressure Gas Safety Law.
Use under conditions where pressure fluctuations (pulsations) exceeding 0.1 MPa do not occur.

Note 2) Based on SMC's measuring conditions.

Construction

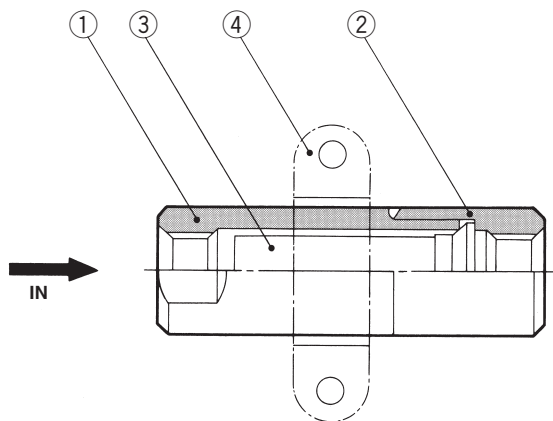

No.	Description	Material	Note
1	Case	Stainless steel 316	Electrolytic polishing (Interior/Exterior)
2	Cover		
3	Element	PTFE membrane	
4	Bracket	Stainless steel 316 sintered meal	

Series SFB300

Flow Characteristics Fluid: Compressed air Inlet temperature: 20 °C

SFB30□-02

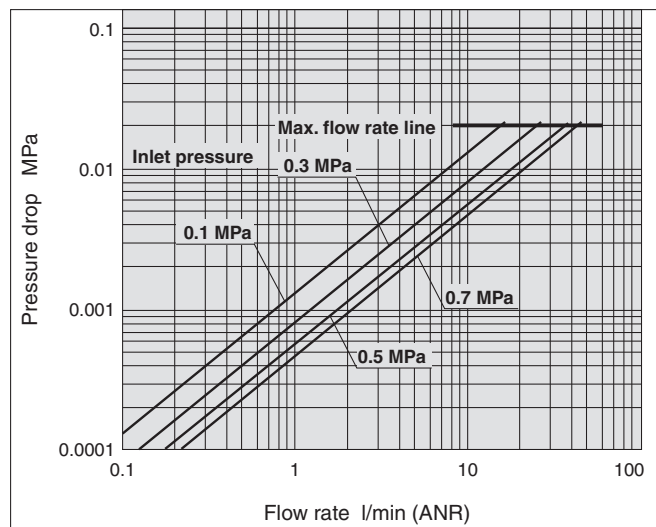

Dimensions

SFB300-02: Rc1/4

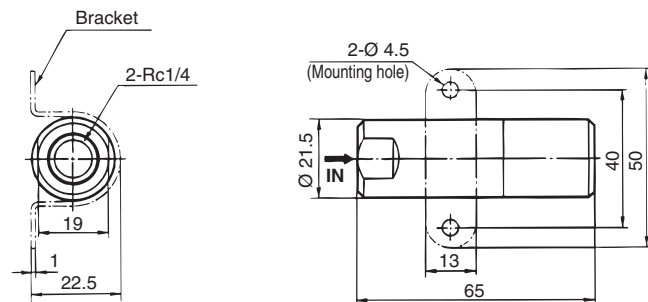

SFB302-02: TSJ1/4 (Tube swage joint)

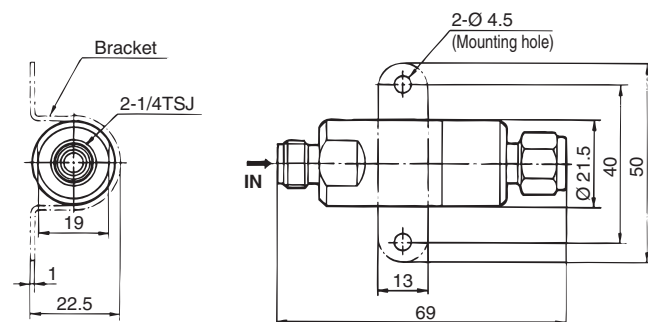

SFB305-02, SFB315-02: URJ1/4 (Union ring joint)

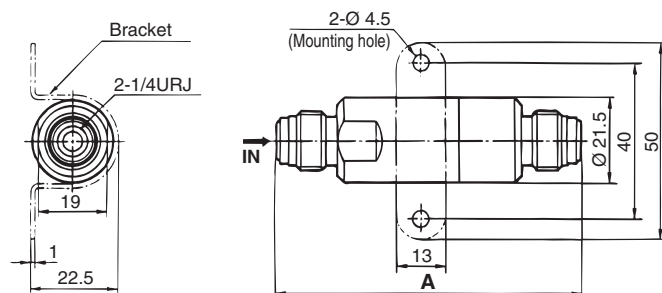

Model	A
SFB305-02	79
SFB315-02	84

Clean Gas Filter: Disposable Type/Multiple Disc Type **SFC100 Series**

RoHS

Precision filtration for compressed air, nitrogen, used in the semiconductor process

PTFE membrane with high reliability

Filtration 0.01 μm
(Filtering efficiency 99.99 %)



How to Order

SFC 10 0 - 02

Clean gas filter
Disposable type
(Multiple disc type)

Model type

Symbol	Rated flow rate l/min (ANR)
10	Up to 240

Port size

Symbol	Port size	
02	Rc, TSJ, URJ	1/4
03	Rc, TSJ, URJ	3/8

Connection

Symbol	Connection (IN, OUT)
0	Rc
2	TSJ
5	URJ

Model

Model	Rated flow rate l/min (ANR) ^{Note)}	Connection	Filtration area cm ²	Weight kg
SFC100-02	240	Rc 1/4 (Female thread)	300	0.35
SFC100-03		Rc 3/8 (Female thread)		0.36
SFC102-02		TSJ 1/4		0.40
SFC102-03		TSJ 3/8		0.41
SFC105-02		URJ 1/4		0.44
SFC105-03		URJ 3/8		0.49

Note) Inlet pressure 0.7 MPa, at pressure drop 0.02 MPa

SFB100 Series

Specifications

Operating fluid		Air, Nitrogen
Operating pressure <small>Note 1)</small>		Max. 0.99 MPa, Vacuum 1.3×10^{-6} kPa
Operating temperature		5 to 120 °C
Element proof differential pressure		Max. 0.42 MPa
Element reverse differential pressure		Max. 0.07 MPa
Filtration <small>Note 2)</small>		0.01 μm (Filtering efficiency 99.99 %)
Helium leak volume		4.0×10^{-9} Pa·m ³ /sec or less
Main material	Case/Cover	Stainless steel 316 (Interior/Exterior: Electrolytic polishing)
	Filter medium	PTFE membrane
	O-ring	PTFE

Note 1) The maximum operating pressure is 0.99 MPa since this product does not conform to the High Pressure Gas Safety Law. Use under conditions where pressure fluctuations (pulsations) exceeding 0.1 MPa do not occur.

Note 2) Based on SMC's measuring conditions.

Construction

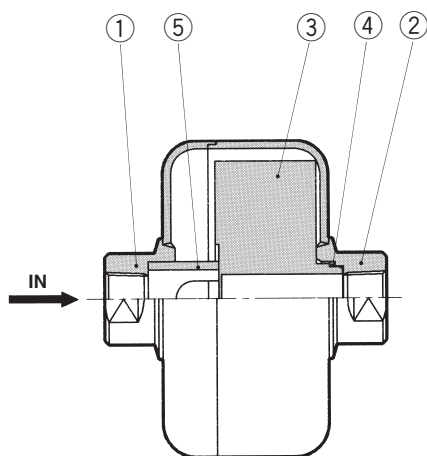

No.	Description	Material	Note
1	Case 1	Stainless steel 316	Electrolytic polishing (Interior/Exterior)
2	Case 2		
3	Element	PTFE, PVDF	
4	O-ring	PTFE	
5	Spacer	PVDF	

Flow Characteristics Fluid: Compressed air Inlet temperature: 20 °C

SFC10□

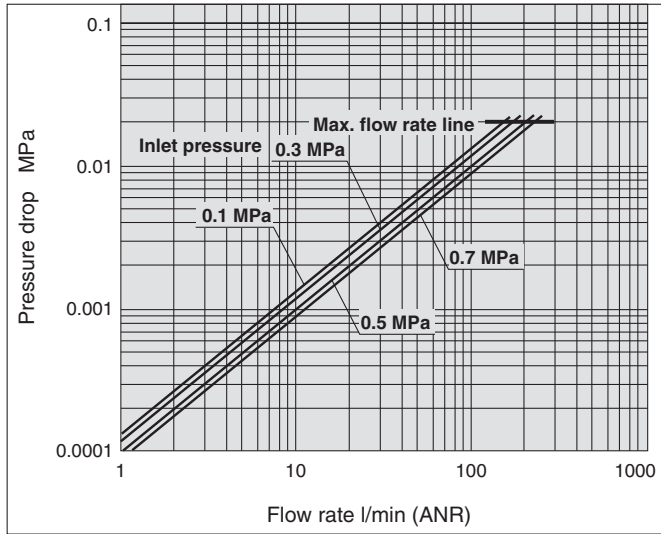

Dimensions

SFC100-02: Rc1/4

SFC100-03: Rc3/8

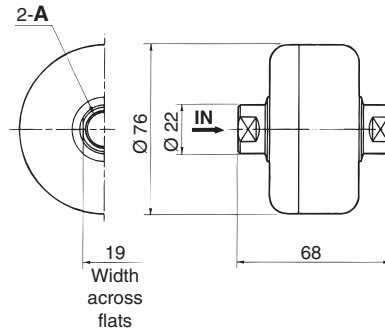

Model	A
SFC100-02	Rc1/4
SFC100-03	Rc3/8

SFC102-02: TSJ1/4 (Tube swage joint)

SFC102-03: TSJ3/8 (Tube swage joint)

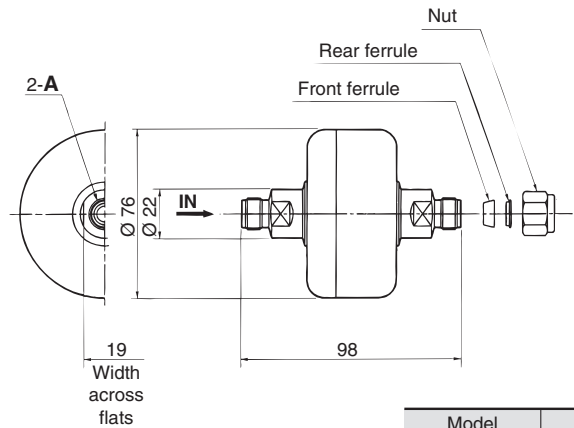

Model	A
SFC102-02	TSJ1/4
SFC102-03	TSJ3/8

SFC105-02: URJ1/4 (Union ring joint)

SFC105-03: URJ3/8 (Union ring joint)

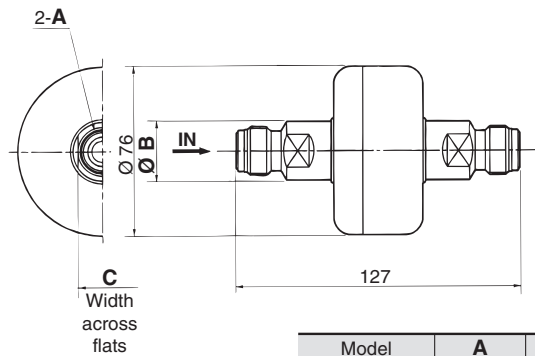

Model	A	B	C
SFC105-02	URJ1/4	22	19
SFC105-03	URJ3/8	26.5	22

SF□ Series Made to Order



Please contact SMC for detailed dimensions, specifications and lead times.

Case/Cover material: Aluminum alloy

Part No.: SFB100-02X8

Specifications

Fluid	Air	
Operating pressure	Max. 0.99 MPa	
Max. operating temperature	80°C	
Element proof differential pressure	Max. 0.5 MPa	
Element reverse differential pressure	Max. 0.07 MPa	
Filtration ^{Note)}	0.01 μm (Filtering efficiency 99.99%)	
Connection	Rc 1/4	
Filtration area	10 cm ²	
Element part no.	ED301S-X10V	
Weight	0.06 kg	
Main material	Case/Cover	A2017 (Clear anodized)
	Seal	Fluororubber (FKM)
	Element	PTFE membrane

Dimensions are identical to the standard models. For details, refer to page 6.
Note) Based on SMC's measuring conditions.

Strainer with other nominal filtration (1,2,5,10,20,40,70,100 μm)

The filtration other than the standard filtration accuracy, 120 μm, is available with the clean gas strainer.

Part No.: SFB200-02-S **002** **V** -X40

Nominal filtration

Symbol	Nominal filtration μm ^{Note 1)}	Rated flow rate L/min (ANR) ^{Note 2)}
001	1	5
002	2	10
005	5	15
010	10	30
020	20	50
040	40	80
070	70	130
100	100	250

Note 1) Nominal filtration refers to value used to categorize raw material.

Note 2) Maximum flow rate at inlet pressure 0.7 MPa. Other specifications and dimensions are identical to the standard models. For details, refer to pages 303 and 305.

O-ring

Symbol	Material
N	NBR
V	FKM
T	PTFE

Element Part No.

Part No.: ES001S- **002** **N** X25

Nominal filtration

Symbol	Nominal filtration μm
001	1
002	2
005	5
010	10
020	20
040	40
070	70
100	100

O-ring

Symbol	Material
N	NBR
V	FKM
T	PTFE



SF□ Series

Specific Product Precautions 1

Be sure to read this before handling the products.

Caution on Design/Selection

⚠ Warning

1. Confirm the specifications.

The clean gas filter is designed for use with only compressed air or nitrogen.

Do not use this product with fluid, pressure or temperature beyond the specifications. Otherwise, they could cause damage to the product.

2. Determine the product by the maximum consumption flow rate.

When using compressed air for an air blow application, calculate the maximum volume of air that will be consumed before selecting the SF□ series product size. (Using a product which exceeds the maximum air flow and running excessive compressed air can cause the cleanliness of the compressed air to deteriorate and/or its element to be damaged.)

3. Set the air flow capacity with an initial pressure drop of 0.02 MPa or less. If the initial pressure drop is set to be too high, the product's replacement cycle will become much shorter due to clogging.

⚠ Caution

1. Do not use under conditions where a pressure difference exceeding 0.1 MPa is present between the inlet side and the outlet side.

Use under such conditions may lead to not only a decline in cleanliness but also element damage.

2. Install in a location where the product will not be subject to pulsations or pressure fluctuations exceeding 0.1 MPa.

Pulsations and pressure fluctuations exceeding 0.1 MPa may damage the product.

3. Use caution regarding the particles that may be emitted from the outlet side of a pneumatic equipment.

Installation of a pneumatic equipment on the outlet side of the SF□ series can deteriorate the cleanliness because a particle will be generated from the equipment. In the case of installing the pneumatic equipment in the outlet side of the SF□ series, dusts can be generated from the equipment, and the degree of cleanliness can be deteriorated.

The mounting position of the pneumatic equipment needs to be considered depending on the degree of cleanliness of a required operating fluid.

4. Design that the piping load should not be applied on the product body.

Mount a bracket for the piping and the other connecting equipment so that the piping load is not applied to the product body.

Caution on Design/Selection

⚠ Caution

5. Generally, the following pollutant particles are contained in compressed air, although the degree of cleanliness of the compressed air is different depending on the compressor type and specifications.

[Pollutant particle substances contained in the compressed air]

- Moisture (drainage)
- Dusts and particles which are in the surrounding air
- Deteriorated oil which is discharged from the compressor
- Solid foreign matter such as rust and/or oil in the piping

- 1) The SF□ series is not compatible with compressed air which contains fluids such as water and/or oil.
- 2) Install a dryer (IDF, IDG, ID series), mist separator (AM series), micro mist separator (AMD series), super mist separator (AME series), or odor removal filter (AMF series), etc., for the source of the air for the SF□ series.

Piping

⚠ Caution

1. Unpacking the sealed package

Since the filter is sealed in an antistatic double bag, the inner package should be unpacked in a clean atmosphere (such as a clean room).

2. Confirm that there is enough space for maintenance before installing and piping this product.

3. Apply a wrench to 2 chamfered flats on the IN side or the OUT side to prevent the housing from rotating.

4. Confirm the IN and the OUT before piping. The product should not be used with the wrong connection.

5. Connection

1) Rc and NPT connection

Confirm that chips from the pipe threads and sealing material do not enter the piping.

Also, when sealant tape is used, leave 1.5 to 2 thread ridges exposed at the end of the threads.

2) TSJ connection

The TSJ fitting is a kind of a self-align fittings. Set it as shown in the figure.

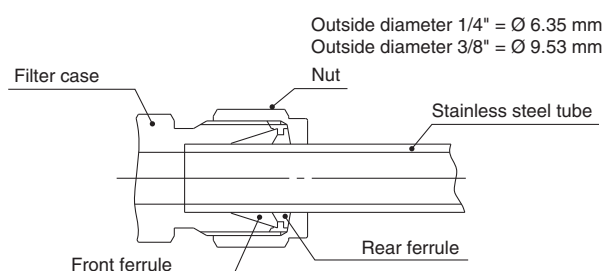



SF□ Series

Specific Product Precautions 2

Be sure to read this before handling the products.

Piping

! Caution

Regarding the TSJ fittings, after tightening the nut by hand, add another 1 1/4 to 1 1/2 turns with a wrench to seal the fitting. In case the fitting is re-installed after filter replacement, first tighten the nut by hand and add another 1/4 to 1/2 turns for sealing. Use the following parts as piping and fittings.

- Piping Outside diameter 1/4" = Ø 6.35 mm
Stainless steel tube

or

- Piping Outside diameter 3/8" = Ø 9.53 mm
Stainless steel tube

- Nut
 - Front ferrule
 - Rear ferrule
- Attached to product (2 pcs each)

In the event of replacing the body, a space (20 mm or longer) for extending the stainless steel tubes from the IN and OUT side will be required.

When using similar fittings of other brands, be sure to conduct a helium leak test to confirm there is no leakage before using.

3) UOJ fittings

The UOJ fitting is a union type fitting using a O-ring seal. Install it as illustrated below.

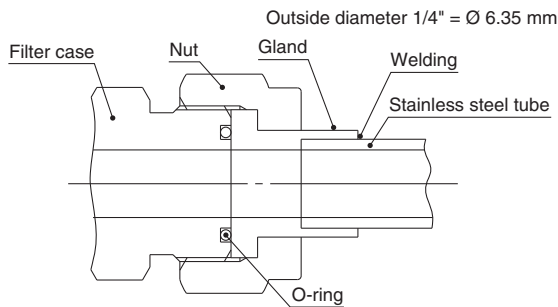

Weld the gland and piping when the fitting is used. At the time of welding, supply inert gas such as Nitrogen to the piping to prevent the formation of an oxide film. Also, remove the oxide film on the external surface through electrolytic polishing or acid cleaning.

After tightening the nut by hand, add another 1/8 turn with a wrench to seal the fitting. Use the following parts for piping and fittings.

- Piping Outside diameter 1/4" = Ø 6.35 mm
Stainless steel tube
 - Nut
 - Gland
 - O-ring
- Attached to product (2 pcs each)

4) URJ fittings

The URJ fitting is a union type fitting using a metal gasket. Install it as illustrated below.

Outside diameter 1/4" = Ø 6.35 mm
Outside diameter 3/8" = Ø 9.53 mm

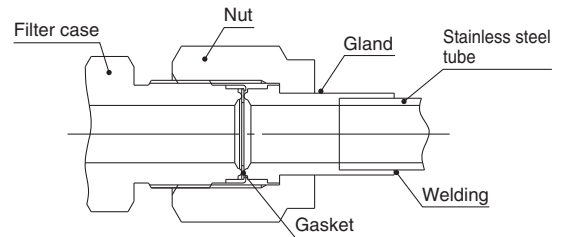

Weld the gland and piping when the fitting is used. At the time of welding, supply inert gas such as Nitrogen to the piping to prevent the formation of an oxide film. Also, remove the oxide film on the external surface through electrolytic polishing or acid cleaning.

After tightening the nut by hand, add another 1/8 turn with a wrench to seal the fitting. Use the following parts for piping and fittings.

<1/4">

- Nut Swagelok® fittings by Swagelok Company
VCR female nut
(SS-4-VCR-1)
- Gland Swagelok® fittings by Swagelok Company
VCR gland
(SS-4-VCR-3)
- Gasket Swagelok® fittings by Swagelok Company
VCR gasket retainer assembly
(SS-4-VCR-2-GR)

<3/8">

- Piping O.D. 3/8" = Ø 9.53 mm
Stainless steel tube
- Nut Swagelok® fittings by Swagelok Company
VCR female nut
(SS-8-VCR-1)
- Gland Swagelok® fittings by Swagelok Company
VCR gland
(SS-6-VCR-3)
- Gasket Swagelok® fittings by Swagelok Company
VCR gasket retainer assembly
(SS-8-VCR-2-GR)

Be sure to conduct a helium leak test before using similar fittings from other companies.

Note) Swagelok is a registered trademark of Swagelok Company



SF□ Series

Specific Product Precautions 3

Be sure to read this before handling the products.

Piping

Caution

6. Line flushing

Flush the piping line when the filter is used for the first time or has been replaced. In the event of connecting such as piping, flush (air blow) when using this product for the first time or replacing its elements in order to reduce the affect of the dust generated from the connection, etc.

Flushing the line is also required to eliminate contamination resulting from the piping line installation. Therefore, be sure to flush the line before actually running the system.

Operating Environment

Caution

1. Use caution in order to prevent workpieces from being damaged by entrained air from the surrounding area.

When the compressed air is used for air blow, the exhausted air from the blow nozzle may have taken in airborne foreign matter (such as solid particle, fluid particle) from the surround air. The foreign matter will be sprayed on the workpiece, and the airborne foreign matter may adhere to it. Therefore, use caution for the surrounding environment.

Maintenance

Caution

1. When the element comes to the end of its life, immediately replace it with a new filter or replacement element.

2. Timing of element replacement

The replacement time for elements is when one of the following conditions occurs.



- 1) After 1 year of usage has elapsed.
- 2) When the pressure drop reaches 0.1 MPa even though the operating period has been less than 1 year.

3. Post maintenance inspection

After installation or repair, perform an appropriate function and leakage test.

Safety Instructions

These safety instructions are intended to prevent hazardous situations and/or equipment damage. These instructions indicate the level of potential hazard with the labels of “**Caution**,” “**Warning**” or “**Danger**.” They are all important notes for safety and must be followed in addition to International Standards (ISO/IEC) ¹⁾, and other safety regulations.

-  **Caution:** **Caution** indicates a hazard with a low level of risk which, if not avoided, could result in minor or moderate injury.
-  **Warning:** **Warning** indicates a hazard with a medium level of risk which, if not avoided, could result in death or serious injury.
-  **Danger:** **Danger** indicates a hazard with a high level of risk which, if not avoided, will result in death or serious injury.

- 1) ISO 4414: Pneumatic fluid power – General rules relating to systems.
- ISO 4413: Hydraulic fluid power – General rules relating to systems.
- IEC 60204-1: Safety of machinery – Electrical equipment of machines. (Part 1: General requirements)
- ISO 10218-1: Manipulating industrial robots - Safety. etc.

Warning

1. The compatibility of the product is the responsibility of the person who designs the equipment or decides its specifications.

Since the product specified here is used under various operating conditions, its compatibility with specific equipment must be decided by the person who designs the equipment or decides its specifications based on necessary analysis and test results. The expected performance and safety assurance of the equipment will be the responsibility of the person who has determined its compatibility with the product. This person should also continuously review all specifications of the product referring to its latest catalogue information, with a view to giving due consideration to any possibility of equipment failure when configuring the equipment.

2. Only personnel with appropriate training should operate machinery and equipment.

The product specified here may become unsafe if handled incorrectly. The assembly, operation and maintenance of machines or equipment including our products must be performed by an operator who is appropriately trained and experienced.

3. Do not service or attempt to remove product and machinery/equipment until safety is confirmed.

1. The inspection and maintenance of machinery/equipment should only be performed after measures to prevent falling or runaway of the driven objects have been confirmed.
2. When the product is to be removed, confirm that the safety measures as mentioned above are implemented and the power from any appropriate source is cut, and read and understand the specific product precautions of all relevant products carefully.
3. Before machinery/equipment is restarted, take measures to prevent unexpected operation and malfunction.

4. Contact SMC beforehand and take special consideration of safety measures if the product is to be used in any of the following conditions.

1. Conditions and environments outside of the given specifications, or use outdoors or in a place exposed to direct sunlight.
2. Installation on equipment in conjunction with atomic energy, railways, air navigation, space, shipping, vehicles, military, medical treatment, combustion and recreation, or equipment in contact with food and beverages, emergency stop circuits, clutch and brake circuits in press applications, safety equipment or other applications unsuitable for the standard specifications described in the product catalogue.
3. An application which could have negative effects on people, property, or animals requiring special safety analysis.
4. Use in an interlock circuit, which requires the provision of double interlock for possible failure by using a mechanical protective function, and periodical checks to confirm proper operation.

Caution

1. The product is provided for use in manufacturing industries.

The product herein described is basically provided for peaceful use in manufacturing industries.

If considering using the product in other industries, consult SMC beforehand and exchange specifications or a contract if necessary. If anything is unclear, contact your nearest sales branch.

Limited warranty and Disclaimer/Compliance Requirements

The product used is subject to the following “Limited warranty and Disclaimer” and “Compliance Requirements”. Read and accept them before using the product.

Limited warranty and Disclaimer

1. The warranty period of the product is 1 year in service or 1.5 years after the product is delivered, whichever is first. ²⁾ Also, the product may have specified durability, running distance or replacement parts. Please consult your nearest sales branch.
 2. For any failure or damage reported within the warranty period which is clearly our responsibility, a replacement product or necessary parts will be provided. This limited warranty applies only to our product independently, and not to any other damage incurred due to the failure of the product.
 3. Prior to using SMC products, please read and understand the warranty terms and disclaimers noted in the specified catalogue for the particular products.
- ²⁾ Vacuum pads are excluded from this 1 year warranty. A vacuum pad is a consumable part, so it is warranted for a year after it is delivered. Also, even within the warranty period, the wear of a product due to the use of the vacuum pad or failure due to the deterioration of rubber material are not covered by the limited warranty.

Compliance Requirements

1. The use of SMC products with production equipment for the manufacture of weapons of mass destruction (WMD) or any other weapon is strictly prohibited.
2. The exports of SMC products or technology from one country to another are governed by the relevant security laws and regulations of the countries involved in the transaction. Prior to the shipment of a SMC product to another country, assure that all local rules governing that export are known and followed.

Caution

SMC products are not intended for use as instruments for legal metrology.

Measurement instruments that SMC manufactures or sells have not been qualified by type approval tests relevant to the metrology (measurement) laws of each country. Therefore, SMC products cannot be used for business or certification ordained by the metrology (measurement) laws of each country.

Safety Instructions

Be sure to read “Handling Precautions for SMC Products” (M-E03-3) before using.

SMC Corporation (Europe)

Austria	+43 (0)2262622800	www.smc.at	office@smc.at
Belgium	+32 (0)33551464	www.smc.be	info@smc.be
Bulgaria	+359 (0)2807670	www.smc.bg	office@smc.bg
Croatia	+385 (0)13707288	www.smc.hr	office@smc.hr
Czech Republic	+420 541424611	www.smc.cz	office@smc.cz
Denmark	+45 70252900	www.smc.dk.com	smc@smcdk.com
Estonia	+372 651 0370	www.smcee.ee	info@smcee.ee
Finland	+358 207513513	www.smc.fi	smcffi@smc.fi
France	+33 (0)164761000	www.smc-france.fr	supportclient@smc-france.fr
Germany	+49 (0)61034020	www.smc.de	info@smc.de
Greece	+30 210 2717265	www.smchellas.gr	sales@smchellas.gr
Hungary	+36 23513000	www.smc.hu	office@smc.hu
Ireland	+353 (0)14039000	www.smcautomation.ie	sales@smcautomation.ie
Italy	+39 03990691	www.smcitalia.it	mailbox@smcitalia.it
Latvia	+371 67817700	www.smc.lv	info@smc.lv

Lithuania	+370 5 2308118	www.smclt.lt	info@smclt.lt
Netherlands	+31 (0)205318888	www.smc.nl	info@smc.nl
Norway	+47 67 129020	www.smc-norge.no	post@smc-norge.no
Poland	+48 222119600	www.smc.pl	office@smc.pl
Portugal	+351 214724500	www.smc.eu	apoioclientept@smc.smces.es
Romania	+40 213205111	www.smcromania.ro	smcromania@smcromania.ro
Russia	+7 (812)3036600	www.smc.eu	sales@smcru.com
Slovakia	+421 (0)413213212	www.smc.sk	office@smc.sk
Slovenia	+386 (0)73885412	www.smc.si	office@smc.si
Spain	+34 945184100	www.smc.eu	post@smc.smces.es
Sweden	+46 (0)86031240	www.smc.nu	smc@smc.nu
Switzerland	+41 (0)523963131	www.smc.ch	info@smc.ch
Turkey	+90 212 489 0 440	www.smcturkey.com.tr	satis@smcturkey.com.tr
UK	+44 (0)845 121 5122	www.smc.uk	sales@smc.uk

South Africa +27 10 900 1233 www.smcza.co.za zasales@smcza.co.za