

## C(D)Q2W, Compact Cylinder, Double Acting Double Rod w/Auto Switch Mounting Groove CQ2WB16-15D

Datasheet

### General series information

- Double acting, double rod, compact cylinder
- Bore sizes (mm): 12, 16, 20, 25, 32, 40, 50, 63, 80, 100
- Standard stroke range (mm): 5 to 100
- Port threads: M (12 to 25 bore); Rc, NPT or G (32 to 100 bore)
- Can mount small auto switches on 4 surfaces.

### Standard specifications

Magnet	None
Mounting	B (Through Hole [Standard])
Type	Standard
Bore Size	Ø16 mm
Port Thread Type	Rc (or M Thread for 16 & 20 Bore or 32 stroke 5 mm)
Stroke	15 mm
Body Option	Standard (Rod End Female Thread)
Auto Switch Groove	None, also for 12-25 Bore w/o Magnet
Auto Switch	No Switch
Lead Wire or Prewired Connector	0.5 m or None in the Case of No Switch
Number	2 pcs. or None in the Case of No Switch
Rod End Options	None
Temperature Resistance	None
Low Speed	None
Made of Stainless Steel	None
Fluororubber Seal	None
Pressure medium	Compressed air
Number of pneumatic connections	2 pcs.

Mode of operation of drive	Double acting
Weight	0.083 Kg

# Dimensions

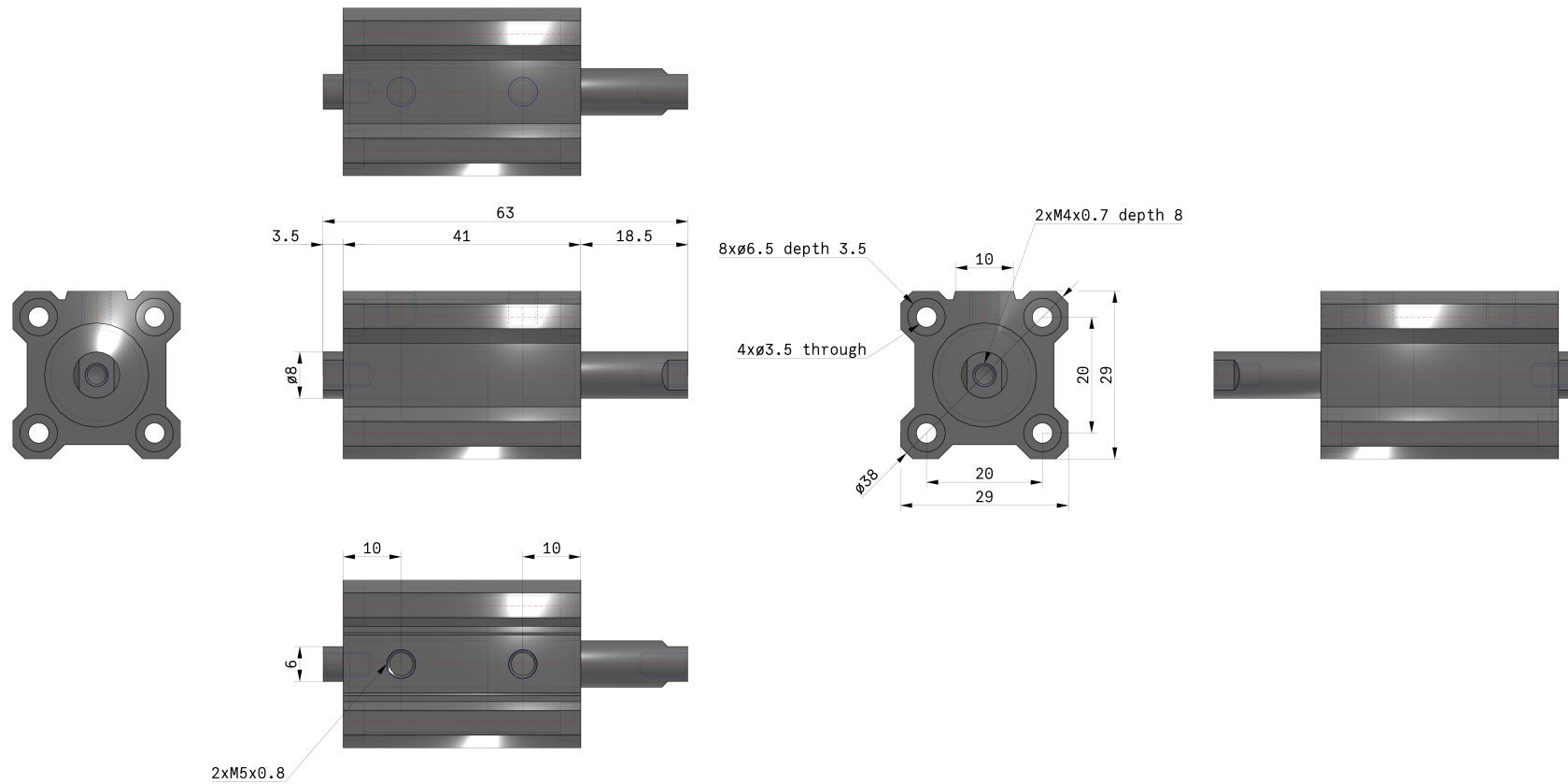

## Additional information

Catalogue

[CQ2-Z-D\\_EU.pdf](#)