

## C(D)85, ISO Standard Cylinder, Double Acting, Single Rod CD85N10-50-A

Datasheet

### General series information

- Double acting, single rod, crimped cylinder
- Conforms to ISO 6432 and CETOP RP52P
- Bore sizes (mm): 8, 10, 12, 16, 20, 25
- Standard strokes up to 300mm
- Auto switch capable



Double-acting, single-rod cylinder

### Standard specifications

|  |   |
|--|---|
| Magnet   | D (Built-in)                              |
| Mounting   | N (Basic Integrated Clevis)               |
| Bore Size  | Ø10 mm                                    |
| Stroke   | 50  |
| Cushion  | Rubber Cushion                            |
| Rod Boot   | None                                      |
| Auto Switch Mounting Type                          | A (Rail)                                  |
| Auto Switch  | No Switch                                 |
| Lead Wire or Prewired Connector                    | 0.5m (Or None in the Case of No Switch)   |
| Number   | 2 pcs. (Or None in the Case of No Switch) |
| Rod End Options                                    | None                                      |
| Temperature Resistance                             | None                                      |
| Low Speed  | None                                      |
| Stainless Steel                                    | None                                      |
| Long Stroke  | None                                      |
| Pressure medium                                    | Compressed Air                            |
| Maximum temperature of pressure medium             | 80 °C                                     |
| Maximum temperature of pressure medium with magnet | 60 °C                                     |

|   |                               |
|---|-------------------------------|
| Minimum temperature of pressure medium                  | -20 °C [without condensation] |
| Minimum temperature of pressure medium with magnet      | -10 °C [without condensation] |
| Maximum operating pressure                              | 1 MPa                         |
| Minimum operating pressure                              | 0.08 MPa                      |
| Proof pressure  | 1.5 MPa                       |
| Maximum ambient temperature                             | 80 °C                         |
| Maximum ambient temperature with magnet                 | 60 °C                         |
| Minimum ambient temperature                             | -20 °C                        |
| Minimum ambient temperature with magnet                 | -10 °C                        |
| Number of pneumatic connections                         | 2 pcs.                        |
| Pneumatic input connection                              | M5                            |
| Pneumatic output connection                             | M5                            |
| Mode of operation of drive                              | Double acting                 |
| Theoretical cylinder force, advance stroke (at 0.5 MPa) | 39.3 N                        |
| Theoretical cylinder force, return stroke (at 0.5 MPa)  | 33.0 N                        |
| Maximum piston speed                                    | 1,500 mm/s                    |
| Type of cushioning                                      | Rubber bumper                 |
| Piston rod end  | External thread               |
| Geometric form of the piston rod                        | Single rod                    |
| Male thread of rod end                                  | M4                            |
| Usable tubing material                                  | Soft nylon;Nylon;Polyurethane |
| Minimum piston speed                                    | 50 mm/s                       |
| Weight  | 0.067 Kg                      |

## Dimensions

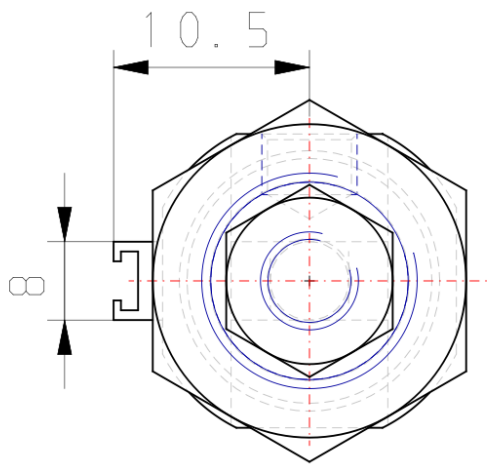
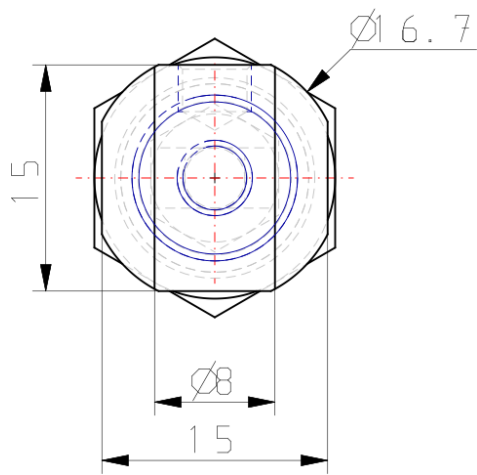

( $\varnothing 0$ ,  $\varnothing 5$ )

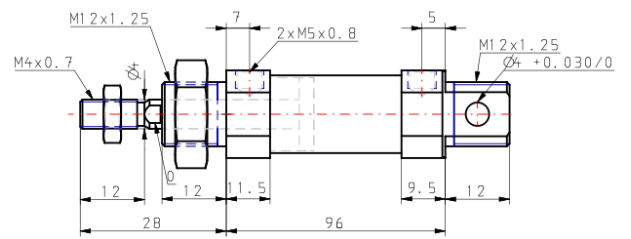
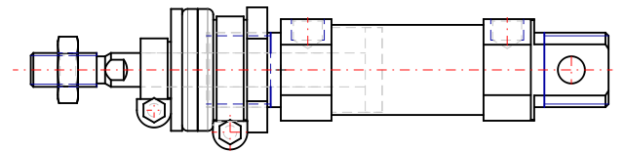

## Constructions

### C□85□20, 25 Rubber bumper



#### Component Parts

| No. | Description   | Material        | Quantity | Remarks            |
|-----|---------------|-----------------|----------|--------------------|
| ①   | Rod cover     | Aluminum alloy  | 1        | White anodized     |
| ②A  | Head cover N  | Aluminum alloy  | 1        | White anodized     |
| ②B  | Head cover E  | Aluminum alloy  | 1        | White anodized     |
| ②C  | Head cover F  | Aluminum alloy  | 1        | White anodized     |
| ②D  | Head cover Y  | Aluminum alloy  | 1        | White anodized     |
| ③   | Cylinder tube | Stainless steel | 1        |                    |
| ④   | Piston rod    | Carbon steel    | 1        | Hard chrome plated |
| ⑤   | Piston        | Aluminum alloy  | 1        | Chromated          |
| ⑥   | Plain washer  | Carbon steel    | 1        | Nickel plated      |
| ⑦   | Bushing       | Sintered bronze | 1        |                    |
| ⑧   | Bushing       | Sintered bronze | 2        |                    |

\* Stainless steel (Non-rotating rod)

| No. | Description    | Material       | Quantity | Remarks             |
|-----|----------------|----------------|----------|---------------------|
| ⑨   | Retaining ring | Carbon steel   | 1        | Nickel plated       |
| ⑩   | Retaining ring | Carbon steel   | 2        |                     |
| ⑪   | Magnet         |                | 1        | (Switch style only) |
| ⑫   | Wear ring      | Phenolic resin | 1        |                     |
| ⑬   | Bumper A       | Urethane       | 1        |                     |
| ⑭   | Bumper B       | Urethane       | 1        |                     |
| ⑮   | Piston gasket  | NBR            | 1        |                     |
| ⑯   | Rod seal       | NBR            | 1        |                     |
| ⑰   | Piston seal    | NBR            | 1        |                     |
| ⑱   | Rod end nut    | Carbon steel   | 1        | Nickel plated       |
| ⑲   | Mounting nut   | Carbon steel   | 1        | Nickel plated       |

## Additional information

Catalogue

[C85\\_C75-A\\_EU.pdf](#)