

## M(D)U Plate Cylinder, Double Acting, Single Rod w/Auto Switch Mounting Groove MDUB32-25DMZ

Datasheet

- Plate Cylinder, Double Acting, Single Rod.
- Reduced labour when mounting the switch.
- Auto-switch doesn't protrude.
- It's possible to mount the autoswitches in four directions.
- A maximum 62% width reduction.

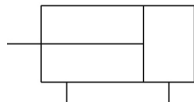

Double-acting, single-rod cylinder

### Standard specifications

Magnet	D (Built-in)
Mounting	B (Basic)
Size	32 (Equiv. Ø32 Piston Area)
Port Thread Type	M thread: ø25, Rc: 32 to 63
Stroke	25
Rod End	M (Male Thread)
Auto Switch	None
Lead Wire or Prewired Connector	0.5m (Or None in the Case of No Switch)
Number	2 pcs. (Or None in the Case of No Switch)
Maximum operating pressure	0.7 MPa
Minimum operating pressure	0.05 MPa
Proof pressure	1.05 MPa
Conform to the European RoHS Directive	Conform
Mode of operation of drive	Double acting
Theoretical cylinder force, advance stroke (at 0.5 MPa)	402 N
Theoretical cylinder force, return stroke (at 0.5 MPa)	325 N
Maximum piston speed	500 mm/s
Type of cushioning	Rubber Bumper
Minimum piston speed	50 mm/s

Lubrication	Not required (non-lube)
Allowable rotational torque	0.25 N·m
Maximum ambient and fluid temperature	60 °C
Minimum ambient and fluid temperature	- 10 °C
Fluid	Air
Rod non-rotating accuracy	±0.8°
Stroke length tolerance	+1.4 0
Weight	0.393 Kg

# Dimensions

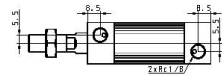
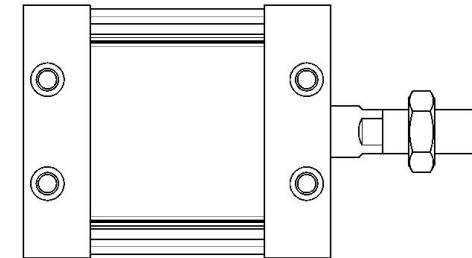
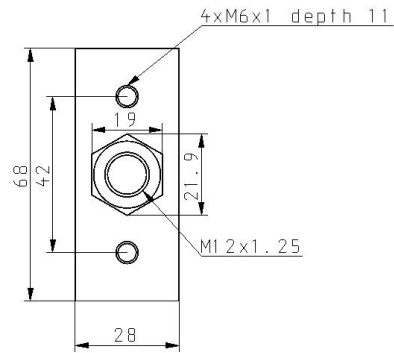
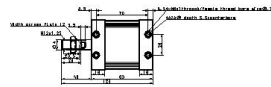
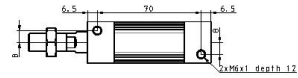

Specifications are subject to change without prior notice and any obligation on the part of the manufacturer.

## Constructions

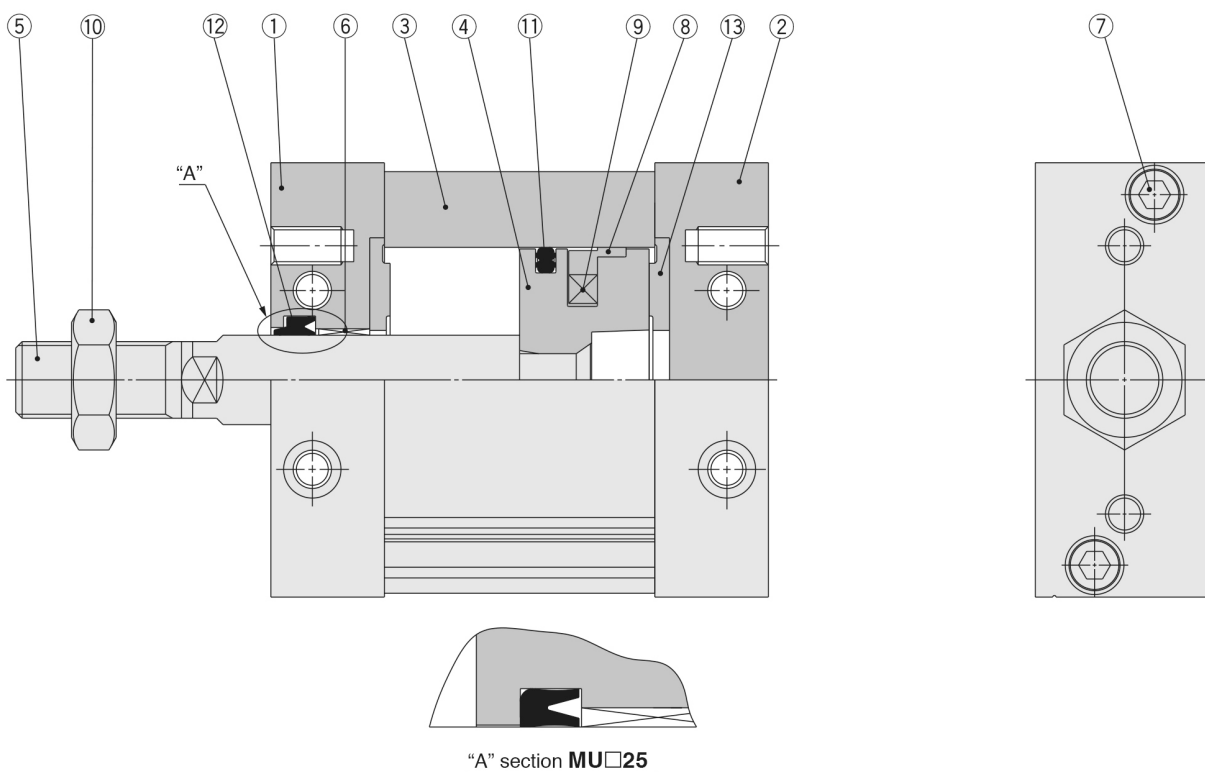

### Component Parts

No.	Description	Material	Note
1	Rod cover	Aluminum alloy	Anodised
2	Head cover	Aluminum alloy	Anodised
3	Cylinder tube	Aluminum alloy	Hard anodised
4	Piston	Aluminum die-casted	Chromated
5	Piston rod	Carbon steel	Hard chrome plated
6	Bushing	Oil-impregnated sintered alloy	
7	Hexagon socket head bolt	Stainless steel	
8	Wear ring	Resin	
9	Magnet	—	Only built-in magnet type
10	Rod end nut	Rolled steel	Only attached to rod end male thread
11	Piston seal	NBR	
12	Rod seal	NBR	
13	Bumper	Urethane	

## Additional information

Catalogue

[MU\\_EU.pdf](#)