



Rotary Table/ Rack-and-Pinion Type



**High Precision type and Clean series
are added to size: 1, 2, 3, 7**

Series *MSQ*

Size: 1, 2, 3, 7, 10, 20, 30, 50, 70, 100, 200

Compact rotary table with Low Table Height

Easy mounting of work piece.

- Table I.D/O.D tolerances
Basic type: **MSQB H9/h9**
High precision type: **MSQA H8/h8**
- Positioning pin hole
- Hollow axis
Accommodates wiring and piping for equipment mounted on the table

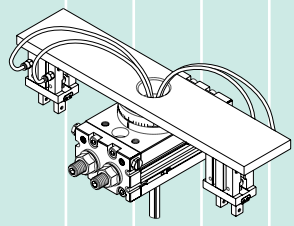

Table inside and outside diameters
For alignment of rotation center and work piece

Positioning pin hole
For position of rotation direction

Hollow axis	
Size	1 2 3 7
Hollow axis	ø3.5 ø3.8 ø5 ø6
Size	10 20 30 50 70 100 200
Hollow axis	ø5 ø9 ø9 ø10 ø16 ø19 ø24

Large rolling element bearing

3 to 4 times higher axial load
(compared with series CRQ)

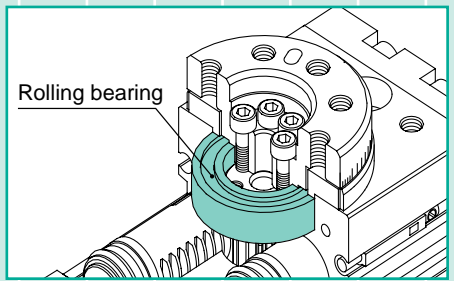

Basic type **MSQB**

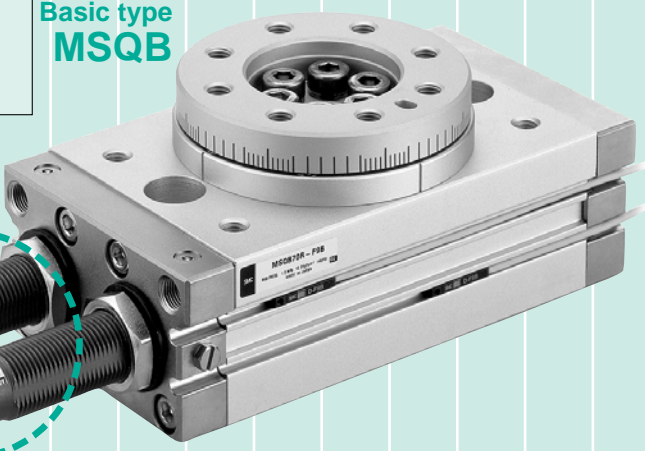

Pivoting angle adjustment range: 0 to 190°

With internal shock absorber

2 to 5 times more kinetic energy
(compared with an adjustment bolt)

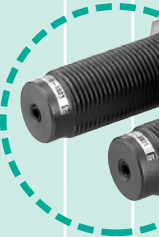

Easy mounting of body

- Reference dia: Boss, Hole
- Mounting from 2 directions
- Positioning pin hole

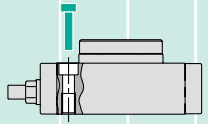
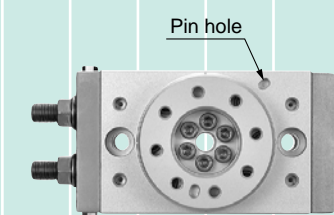

High precision type **MSQA**

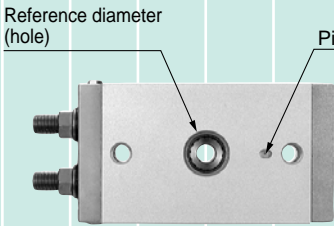
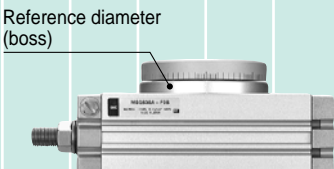

Movement in direction of table's radial thrust: 0.01 mm or less

By using high precision bearing, the movement in the direction of table's radial thrust is reduced.

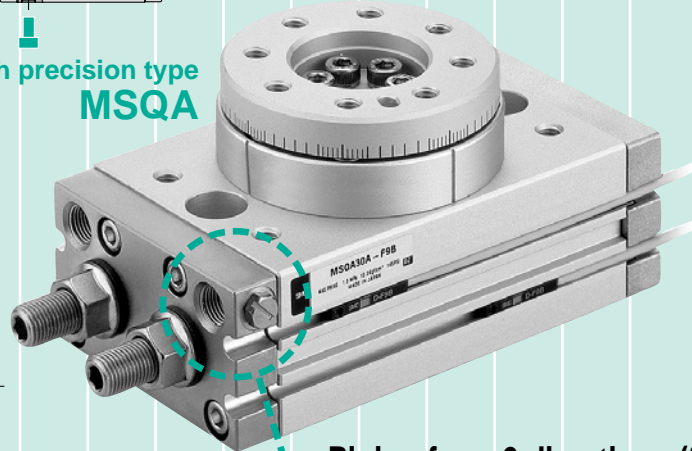
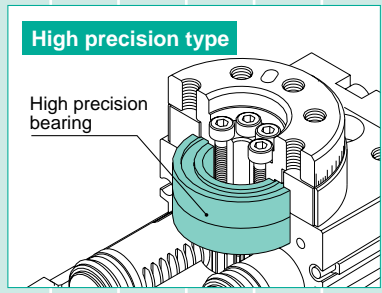

Piping from 2 directions (front and side) is possible

Piping position can be selected to accommodate mounting conditions

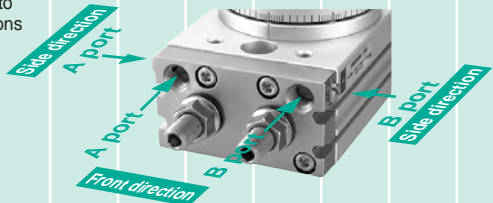

Rotary Table
Series MSQ
 Rack-and-Pinion Type



Small sizes 1, 2, 3, and 7

Small size and light weight

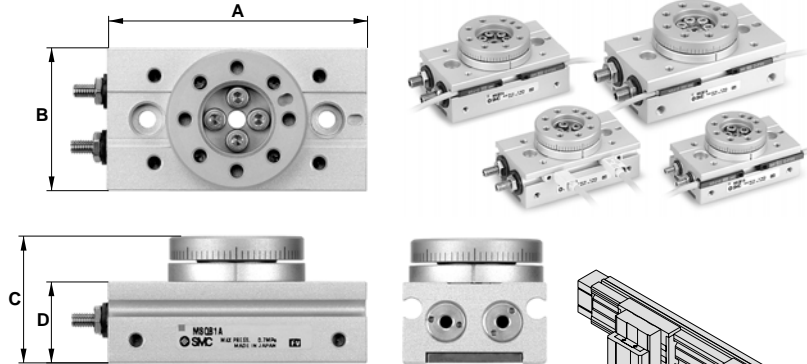

Full size (Picture of MSQB1A)

Measure		mm				Mass (g)
Size	Model	A	B	C	D	
1	MSQB1A	50.5	28	25	16	70
2	MSQB2A	56	30	28	18	105
3	MSQB3A	60	34.5	30.5	20.5	150
7	MSQB7A	73.5	41	34.5	23	250

Variety of installation options for space saving

Offers maximum space saving installation by taking advantage of the compact body, space saving wiring and piping.

Free mount

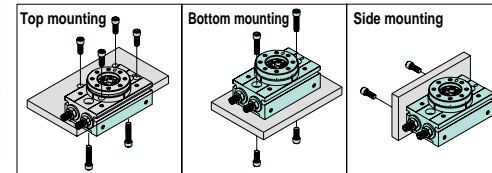

Easy centre alignment at mounting

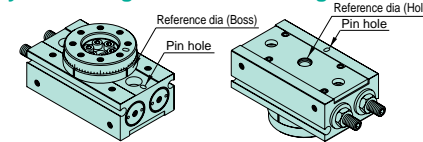

Wiring and piping can be selected according to mounting conditions

Example of auto switch and speed controller mounting

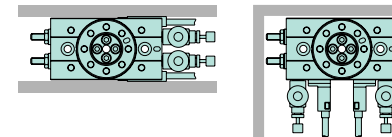

External shock absorber types

4 to 10 times more allowable kinetic energy

(Compared with internal shock absorber type)

2 types of shock absorbers are available, for low energy and high energy.

Allowable kinetic energy comparison (for size 30)

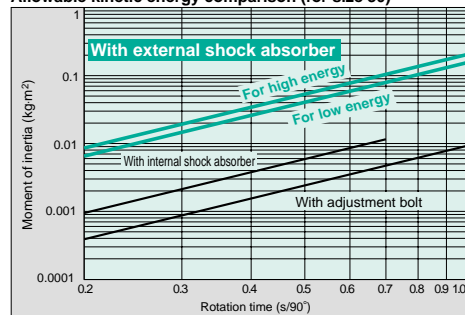

Total length shortened

Longitudinal mounting space is reduced because there is no protrusion from adjustment bolts or internal shock absorbers.

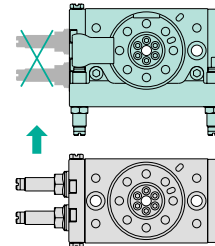
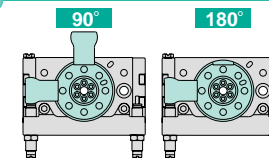
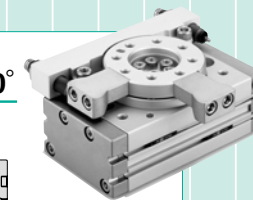
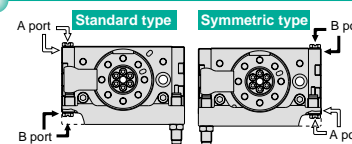

Table height is the same for both types with adjustment bolts or internal shock absorbers.

Rotation angle: 90°, 180°



Left / Right symmetric type



Series MSQ Model Selection

Basic type/MSQB

Additional series

Size	With adjustment bolt		With internal shock absorber		With external shock absorber
	●	Clean	—	Clean	
1	●	●	—	—	—
2	●	●	—	—	—
3	●	●	—	—	—
7	●	●	—	—	—
10	●	●	●	●	●
20	●	●	●	●	●
30	●	●	●	●	●
50	●	●	●	●	●
70	●	—	●	—	—
100	●	—	●	—	—
200	●	—	●	—	—

High precision/MSQA

Additional series

Size	With adjustment bolt		With internal shock absorber		With external shock absorber
	●	Clean	—	Clean	
1	●	●	—	—	—
2	●	●	—	—	—
3	●	●	—	—	—
7	●	●	—	—	—
10	●	●	●	●	●
20	●	●	●	●	●
30	●	●	●	●	●
50	●	●	●	●	●

High Precision type and Clean series are added to size: 1, 2, 3, 7



INDEX

P.7



Size: 1, 2, 3, 7

P.12



Size: 10, 20, 30
50, 70, 100
200

P.19



With external shock absorber
Size: 10, 20
30, 50

Features 3

Model Selection Procedure

Formula

Selection Example

1 Operating conditions

Enumerate the operating conditions according to the mounting position.

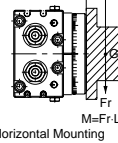
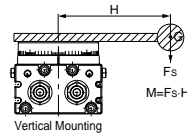

- Model used
- Operating pressure
- Mounting orientation
- Load type
- Ts (N·m)
- Tf (N·m)
- Ta (N·m)

- Load configuration
- Rotation time t (s)
- Rotation angle θ (rad)
- Load mass m (kg)
- Distance between central axis and center of gravity H (mm)
- Mass point distance L (mm)

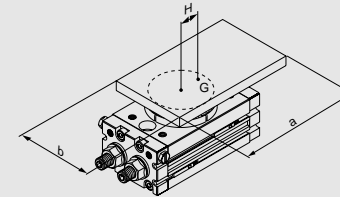

Rotary table: MSQB50A, Pressure: 0.5 MPa
Mounting orientation: Vertical
Load type: Inertial load Ta
Load configuration: 100 mm x 60 mm (Rectangular plate)
Rotation time t: 0.3s, Rotation angle: 90°
Load mass m: 0.4 kg
Distance between central axis and centre of gravity H: 40 mm

2 Required torque

Confirm the type of load as shown below, and select an actuator that satisfies the required torque.

- Static load: Ts
- Resistance load: Tf
- Inertial load: Ta

Load types

Effective torque $\geq Ts$
Effective torque $\geq (3 \text{ to } 5) \cdot Tf$
Effective torque $\geq 10 \cdot Ta$
Effective torque

Inertial load
 $10 \times Ta = 10 \times I \times \dot{\omega}$
 $= 10 \times 0.00109 \times (2 \times (\pi/2) / 0.3)^2$
 $= 0.380 \text{ N}\cdot\text{m} < \text{Effective torque} \quad \text{OK}$
Note) I substitutes for \odot the value for inertial moment.

3 Rotation time

Confirm that it is within the adjustable range of rotation time.

0.2 to 1.0 s / 90°

0.3 s / 90° OK

4 Allowable load

Confirm that the radial load, thrust load and moment are within the allowable ranges.

Thrust load: $m \times 9.8 \leq \text{Allowable load}$
Moment: $m \times 9.8 \times H \leq \text{Allowable moment}$
Allowable load

$0.4 \times 9.8 = 3.92 \text{ N} < \text{Allowable load} \quad \text{OK}$
 $0.4 \times 9.8 \times 0.04 = 0.157 \text{ N}\cdot\text{m}$
 $0.157 \text{ N}\cdot\text{m} < \text{Allowable moment} \quad \text{OK}$

5 Inertial moment

Find the load's inertial moment "I" for the energy calculation.

$I = m \times (a^2 + b^2) / 12 + m \times H^2$
Inertial moment

$I = 0.4 \times (0.10^2 + 0.06^2) / 12 + 0.4 \times 0.04^2$
 $= 0.00109 \text{ kg}\cdot\text{m}^2$

6 Kinetic energy

Confirm that the load's kinetic energy is within the allowable value.

$1/2 \times I \times \omega^2 \leq \text{allowable energy}$
 $\omega = 2\theta / t$ (ω : Terminal angular velocity)
 θ : Rotation angle (rad)
t: Rotation time (s)
Allowable kinetic energy/Rotation time

$1/2 \times 0.00109 \times (2 \times (\pi/2) / 0.3)^2$
 $= 60 \text{ mJ} < \text{Allowable energy} \quad \text{OK}$

Effective Torque

Unit: N·m

Size	Operating pressure (MPa)									
	0.1	0.2	0.3	0.4	0.5	0.6	0.7	0.8	0.9	1.0
1	0.017	0.035	0.052	0.070	0.087	0.10	0.12	—	—	—
2	0.035	0.071	0.11	0.14	0.18	0.21	0.25	—	—	—
3	0.058	0.12	0.17	0.23	0.29	0.35	0.41	—	—	—
7	0.11	0.22	0.33	0.45	0.56	0.67	0.78	—	—	—
10	0.18	0.36	0.53	0.71	0.89	1.07	1.25	1.42	1.60	1.78
20	0.37	0.73	1.10	1.47	1.84	2.20	2.57	2.93	3.29	3.66
30	0.55	1.09	1.64	2.18	2.73	3.19	3.82	4.37	4.91	5.45
50	0.9	1.85	2.78	3.71	4.64	5.57	6.50	7.43	8.35	9.28
70	1.36	2.72	4.07	5.43	6.79	8.15	9.50	10.9	12.2	13.6
100	2.03	4.05	6.08	8.11	10.1	12.2	14.2	16.2	18.2	20.3
200	3.96	7.92	11.9	15.8	19.8	23.8	27.7	31.7	35.6	39.6

Note) Effective torque values are representative values and not to be considered as guaranteed values. Use them as a guide.

Size: 1 to 7

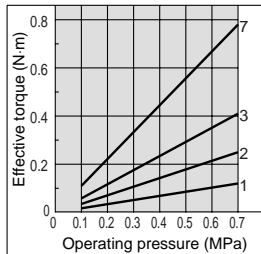

Size: 10 to 50

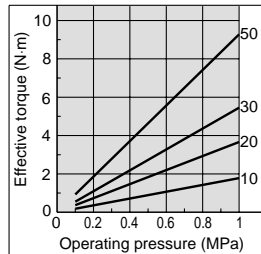

Size: 70 to 200

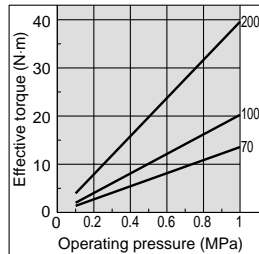

Allowable Load

Do not allow the load and moment applied to the table to exceed the allowable values shown in the table below. (Operation beyond the allowable values can cause adverse effects on service life, such as play in the table and loss of accuracy.)

Size	Allowable radial load (N)		Allowable thrust load (N)				Allowable moment (N·m)	
	Basic type	High precision type	(a)		(b)		Basic type	High precision type
			Basic type	High precision type	Basic type	High precision type		
1	31	31	41	41	41	41	0.56	0.84
2	32	32	45	45	45	45	0.82	1.2
3	33	33	48	48	48	48	1.1	1.6
7	54	54	71	71	71	71	1.5	2.2
10	78	86	74	74	78	107	2.4	2.9
20	147	166	137	137	137	197	4.0	4.8
30	196	233	197	197	363	398	5.3	6.4
50	314	378	296	296	451	517	9.7	12.0
70	333	—	296	—	476	—	12.0	—
100	390	—	493	—	708	—	18.0	—
200	543	—	740	—	1009	—	25.0	—

Load Types

● Static load: Ts

A load as represented by the clamp which requires pressing force only

(During examination if it is decided to consider the mass of the clamp itself in the drawing below, it should be regarded as an inertial load.)

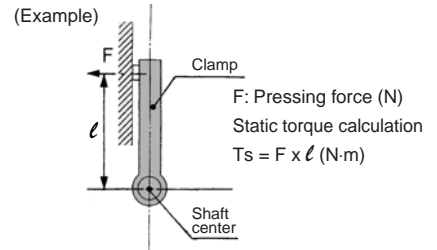

● Resistance load: Tf

A load that is affected by external forces such as friction or gravity

Since the object is to move the load, and speed adjustment is necessary, allow an extra margin of 3 to 5 times in the effective torque.

*Actuator effective torque $\geq (3 \text{ to } 5) T_f$
(During examination if it is decided to consider the mass of the lever itself in the drawing below, it should be regarded as an inertial load.)

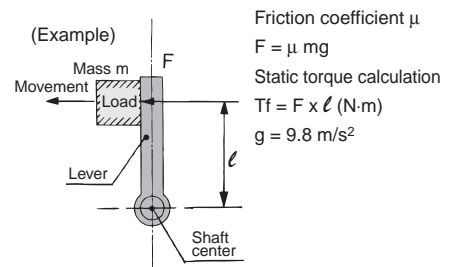

● Inertial load: Ta

A load that must be rotated by the actuator. Since the object is to rotate the inertial load, and speed adjustment is necessary, allow an extra margin of 10 times or more in the effective torque.

*Actuator effective torque $\geq S \cdot T_a$
(S is 10 times or more)

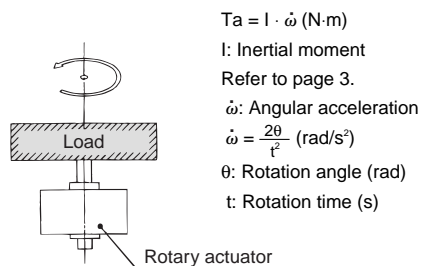

Inertial Moment Formula (Calculation of Inertial Moment I)

I: Inertial moment kg·m² m: Load mass kg

① Thin shaft

Position of rotational axis:
Perpendicular to the shaft
through one end

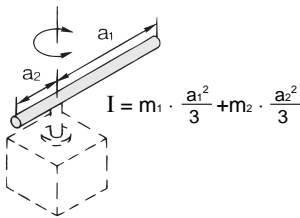

② Thin shaft

Position of rotational axis:
Through the shaft's centre of
gravity

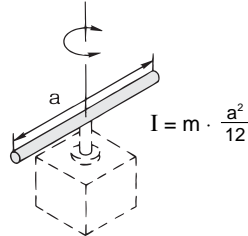

③ Thin rectangular plate (Rectangular parallelepiped)

Position of rotational axis:
Through the plate's centre of
gravity

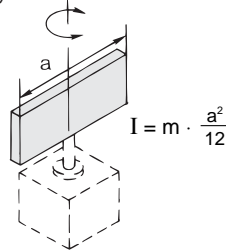

④ Thin rectangular plate (Rectangular parallelepiped)

Position of rotational axis:
Perpendicular to the plate through
one of its points (also the
same in case of a thicker plate)

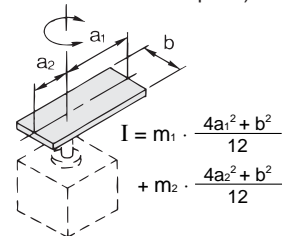

⑤ Thin rectangular plate (Rectangular parallelepiped)

Position of rotational axis:
Through the centre of gravity and
perpendicular to the plate (also
the same in case of a thicker
plate)

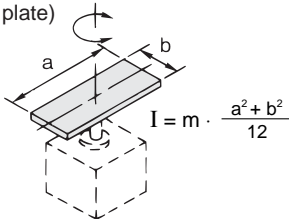

⑥ Cylinder (Including thin round plate)

Position of rotational axis:
Centre axis

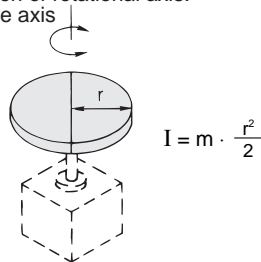

⑦ Solid sphere

Position of rotational axis:
Diameter

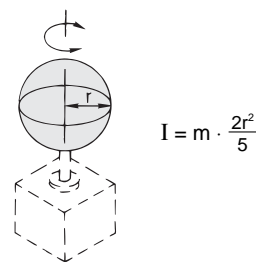

⑧ Thin round plate

Position of rotational axis: Diameter

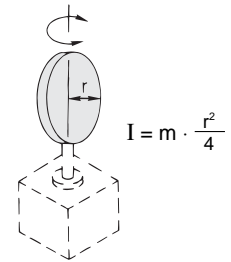

⑨ Load at lever end

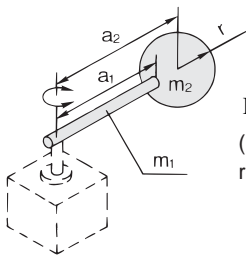

$$I = m_1 \cdot \frac{a_1^2}{3} + m_2 \cdot a_2^2 + K$$

(Example) When shape of m_2 is a sphere,
refer to 7, and $K = m_2 \cdot \frac{2r^2}{5}$

⑩ Gear transmission

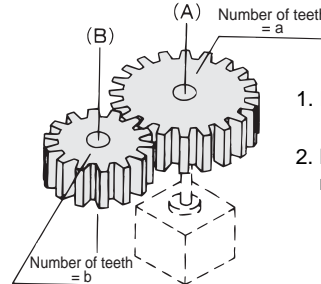

1. Find the inertial moment I_B for the rotation of shaft (B).
2. Next, I_B is entered to find I_A the inertial moment for the rotation of shaft (A) as $I_A = \left(\frac{a}{b}\right)^2 \cdot I_B$

Kinetic Energy/Rotation Time

Even in cases where the torque required for rotation of the load is small, damage to internal parts may result from the inertial force of the load.

Select models giving consideration to the load's inertial moment and rotation time during operation.

(The inertial moment and rotation time charts can be used for your convenience in making model selections on page 4.)

① Allowable kinetic energy and rotation time adjustment range

From the table below, set the rotation time within the adjustment range for stable operation. Note that operation exceeding the rotation time adjustment range, may lead to sticking or stopping of operation.

Size	Allowable kinetic energy (mJ)				Rotation time adjustment range for stable operation s/90°		
	With adjustment bolt	With internal shock absorber	With external shock absorber		With adjustment bolt	With internal shock absorber	With external shock absorber
			For low energy	For high energy			
1	1	-	-	-	0.2 to 0.7	-	-
2	1.5						
3	2						
7	6						
10	7	39	161	231	0.2 to 1.0	0.2 to 0.7	0.2 to 1.0 ^{Note)}
20	25	116	574	1060			
30	48	116	805	1210			
50	81	294	1310	1820			
70	240	1100	-	-	0.2 to 1.5	0.2 to 1.0	-
100	320	1600			0.2 to 2.0		
200	560	2900			0.2 to 2.5		

Note) Refer to the note regarding the rotation time adjustment range on page 20.

② Inertial moment calculation

Since the formula for inertial moment differ depending on the configuration of the load, refer to the inertial moment calculation formula on this page.

Kinetic Energy/Rotation Time

③ **Model selection** Select models by applying the inertial moment and rotation time which have been found to the charts below.

With adjustment bolt

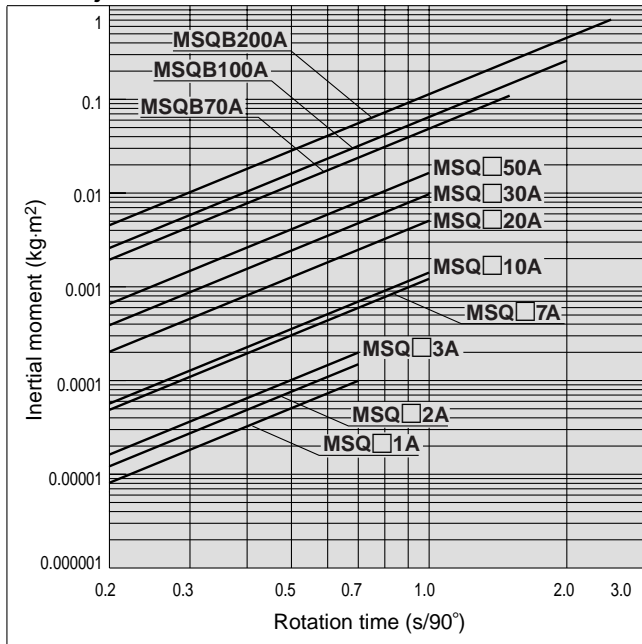

With internal shock absorber

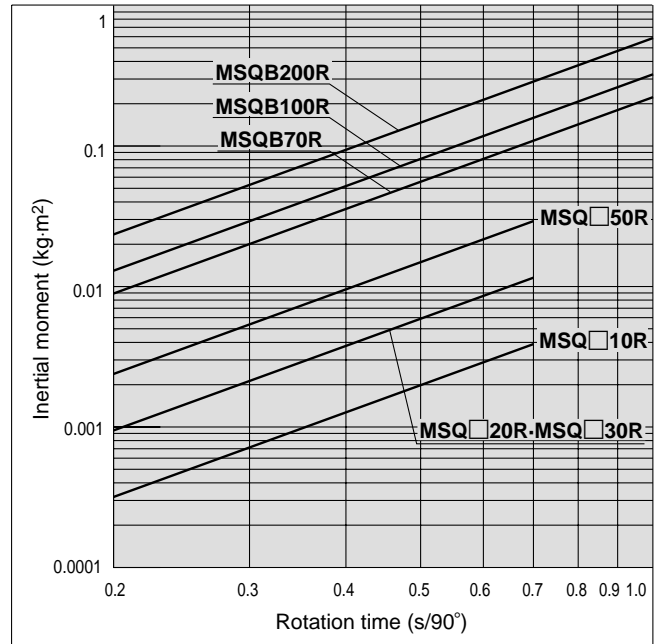

With external shock absorber

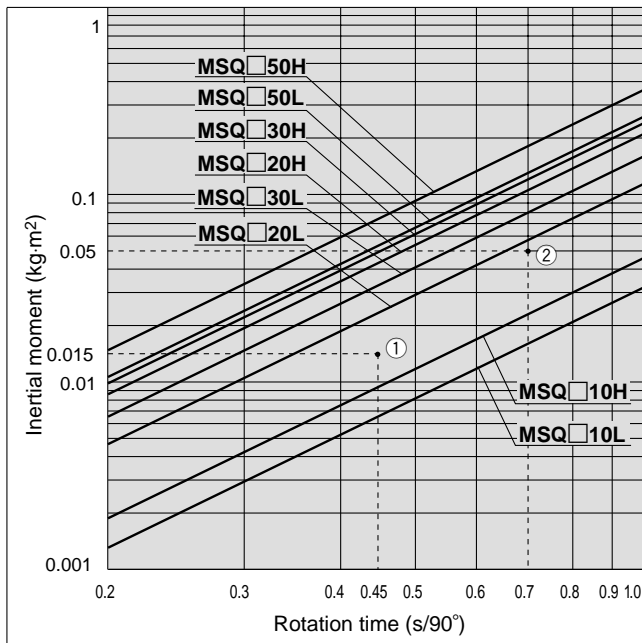

① <Viewing the charts>

- Inertial moment 0.015 kg·m²
 - Rotation time 0.45 s/90°
- MSQ□20L is selected for the above.

② <Example>

Load configuration: A cylinder of radius 0.5 m and mass 0.4 kg
 Rotation time: 0.7 s/90°

$$I = 0.4 \times \frac{0.5^2}{2} = 0.05 \text{ kg}\cdot\text{m}^2$$

In the inertial moment and rotation time chart, find the intersection of the lines extended from the points corresponding to 0.05 kg·m² on the vertical axis (inertial moment) and 0.7 s/90° on the horizontal axis (rotation time). Since the resulting intersection point lines within the MSQ□20L selection range, MSQ□20L can be selected.

Rotation Accuracy: Displacement Value at 180° (reference value)

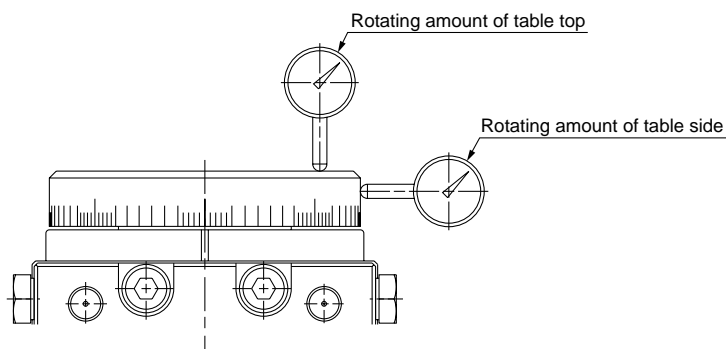

Measuring plate	MSQA	MSQB
Rotating amount of table top	0.03	0.1
Rotating amount of table side	0.03	0.1

Values in the table are actual values and not guaranteed values.

Series MSQ

Table Displacement (reference values)

- The following graphs show the displacement at point A, which is 100 mm apart from the center of rotation, where the load is applied.

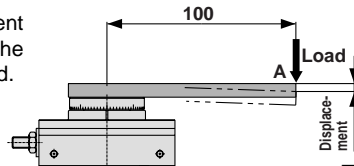

MSQ□1A

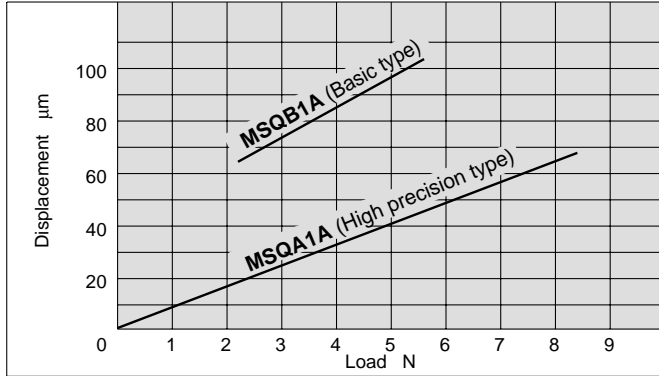

MSQ□10□

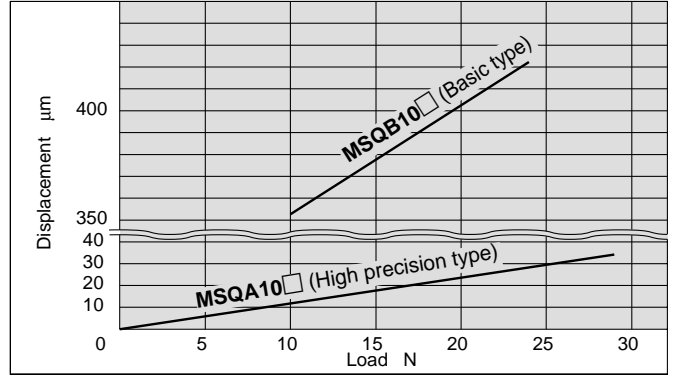

MSQ□2A

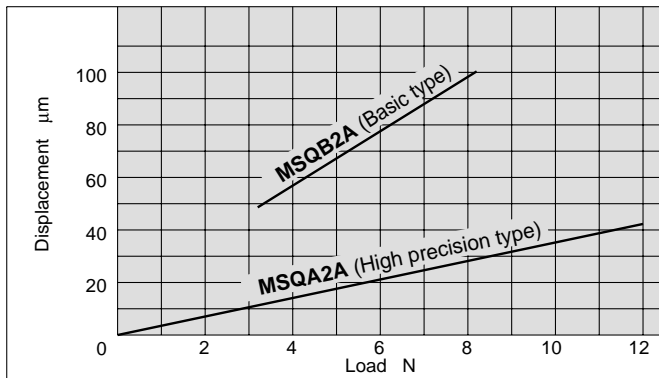

MSQ□20□

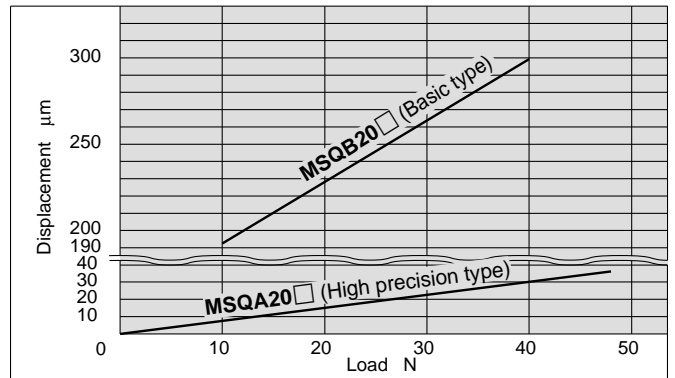

MSQ□3A

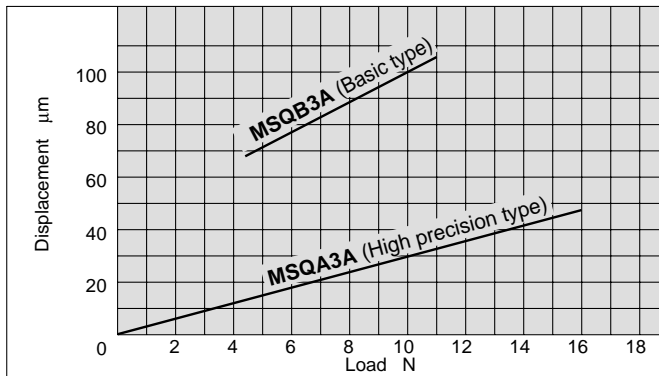

MSQ□30□

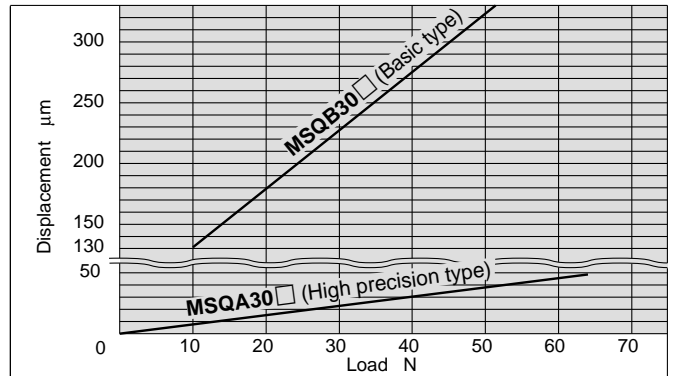

MSQ□7A

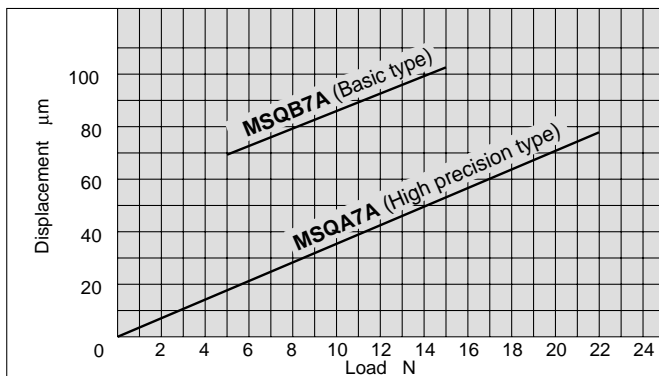

MSQ□50□

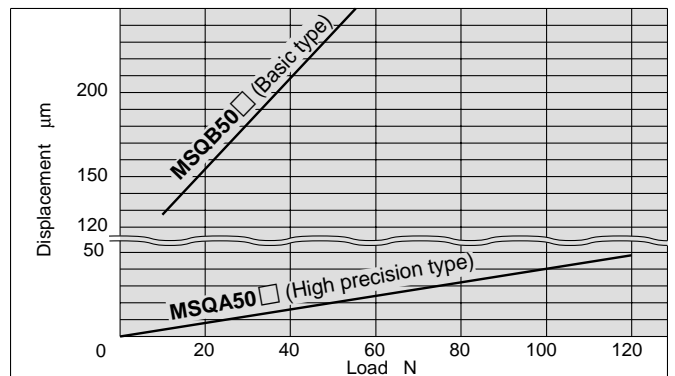

Rotary Table Air Consumption

Air consumption is the volume of air which is expended by the rotary table's reciprocal operation inside the actuator and in the piping between the actuator and the switching valve, etc. This is necessary for selection of a compressor and for calculation of its running cost.

*The air consumption (Q_{CR}) required for one reciprocation of the rotary table alone is shown in the table below, and can be used to simplify the calculation.

Formulae

$$Q_{CR} = 2V \times \left(\frac{P+0.1}{0.1} \right) \times 10^{-3}$$

$$Q_{CP} = 2 \times a \times \ell \times \frac{P}{0.1} \times 10^{-6}$$

$$Q_C = Q_{CR} + Q_{CP}$$

Q_{CR} =	Air consumption of rotary table	[ℓ (ANR)]
Q_{CP} =	Air consumption of tubing or piping	[ℓ (ANR)]
V =	Internal volume of rotary table	[cm ³]
P =	Operating pressure	[MPa]
ℓ =	Length of piping	[mm]
a =	Internal cross section of piping	[mm ²]
Q_C =	Air consumption required for one reciprocation of rotary table	[ℓ (ANR)]

When selecting a compressor, it is necessary to choose one which has sufficient reserve for the total air consumption of all pneumatic actuators downstream. This is affected by factors such as leakage in piping, consumption by drain valves and pilot valves, etc., and reduction of air volume due to drops in temperature.

Formula

$$Q_{C2} = Q_C \times n \times \text{Number of actuators} \times \text{Reserve factor}$$

Q_{C2} = Compressor discharge flow rate [ℓ/min(ANR)]
 n = Actuator reciprocations per minute

Internal cross section of tubing and steel piping

Nominal size	O. D. (mm)	I. D. (mm)	Internal cross section a (mm ²)
T□0425	4	2.5	4.9
T□0604	6	4	12.6
TU 0805	8	5	19.6
T□0806	8	6	28.3
1/8B	—	6.5	33.2
T□1075	10	7.5	44.2
TU 1208	12	8	50.3
T□1209	12	9	63.6
1/4B	—	9.2	66.5
TS 1612	16	12	113
3/8B	—	12.7	127
T□1613	16	13	133
1/2B	—	16.1	204
3/4B	—	21.6	366
1B	—	27.6	598

Air Consumption

Air consumption of rotary table: Q_{CR} ℓ (ANR)

Size	Rotation angle	Internal volume (cm ³)	Operating pressure (MPa)									
			0.1	0.2	0.3	0.4	0.5	0.6	0.7	0.8	0.9	1.0
1	190°	0.66	0.0026	0.0039	0.0052	0.0065	0.0078	0.0091	0.010	—	—	—
2		1.3	0.0052	0.0077	0.010	0.013	0.015	0.018	0.021	—	—	—
3		2.2	0.0087	0.013	0.017	0.022	0.026	0.030	0.035	—	—	—
7		4.2	0.017	0.025	0.033	0.042	0.050	0.058	0.066	—	—	—
10		6.6	0.026	0.040	0.053	0.066	0.079	0.092	0.106	0.119	0.132	0.145
20		13.5	0.054	0.081	0.108	0.135	0.162	0.189	0.216	0.243	0.270	0.297
30		20.1	0.080	0.121	0.161	0.201	0.241	0.281	0.322	0.362	0.402	0.442
50		34.1	0.136	0.205	0.273	0.341	0.409	0.477	0.546	0.614	0.682	0.750
70		50.0	0.200	0.300	0.400	0.500	0.600	0.700	0.800	0.900	1.000	1.100
100		74.7	0.299	0.448	0.598	0.747	0.896	1.046	1.195	1.345	1.494	1.643
200		145.9	0.584	0.875	1.167	1.459	1.751	2.043	2.334	2.626	2.918	3.210

Rotary Table/Rack-and-Pinion Type Series MSQ

Size: 1, 2, 3, 7

How to Order

High Precision Type

MSQA 1 A [] M9B []

Basic Type

MSQB 1 A [] M9B []

Size

1
2
3
7

A With adjustment bolt

Number of auto switches

Nil	2 pcs.
S	1 pc.
n	n pcs.

Auto switch type

Nil Without auto switch (built-in magnet)

* Refer to the table below for auto switch types.

* The auto switch is included in the package (unmounted).

Port location

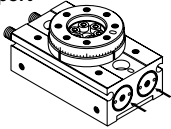
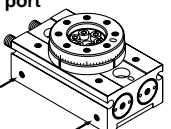
Nil	Side port 
E	Front port 

Applicable auto switches: Refer to pages 25 through 31 for detailed auto switch specifications.

Type	Special function	Electrical entry	Indicator light	Wiring (Output)	Load voltage			Auto switch type		Lead wire length (m)*			Applicable load	
					DC	AC		Electrical entry direction		0.5 (Nil)	3 (L)	5 (Z)		
								Perpendicular	In-line					
Solid state switch	—	Grommet	Yes	3-wire (NPN)	24 V	12 V	—	F8N	M9N	●	●	○	IC circuit	Relay, PLC
				3-wire (PNP)				F8P	M9P	●	●	○		
				2-wire				F8B	M9B	●	●	○		
	Diagnostic indication (2-colour display)			3-wire (NPN)				—	M9NW	●	●	○	IC circuit	
				3-wire (PNP)				—	M9PW	●	●	○		
				2-wire				—	M9BW	●	●	○		

* Lead wire length symbols: 0.5 m Nil (Example) M9N
 3 m L (Example) M9NL
 5 m Z (Example) M9NZ

* Solid state switches marked "○" are produced upon receipt of order.

Made to Order → Contact SMC.

- -50 Without indicator light
- -61 Flexible lead wire
- Pre-wire connector

Specifications



Basic type



High precision type

JIS symbol

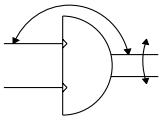

Size	1	2	3	7
Fluid	Air (non-lube)			
Maximum operating pressure	0.7 MPa			
Minimum operating pressure	0.1 MPa			
Ambient and fluid temperature	0 to 60°C (with no freezing)			
Cushion	None		Rubber bumper	
Angle adjustment range	0 to 190°			
Maximum rotation	190°			
Cylinder bore size	ø6	ø8	ø10	ø12
Port size	M3			M5

Allowable Kinetic Energy and Rotation Time Adjustment Range

Size	Allowable kinetic energy (mJ)	Rotation time adjustment range for suitable operation (s/90°)
1	1	0.2 to 0.7
2	1.5	
3	2	
7	6	0.2 to 1.0

Weight

(g)

Size	1	2	3	7
Basic type	75	105	150	250
High precision type	80	115	165	265

Note) Excluding the weight of auto switches

Clean Series

Prevents dispersion of the particles generated inside of the product into the clean room by sucking them out of the vacuum port on the body side.

How to Order

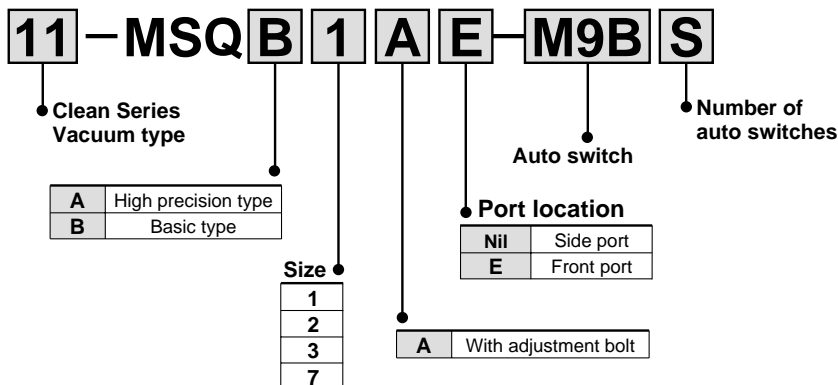

Specifications and allowable load

Particle generation grade	Grade 1 <small>Note 1)</small>
Suction flow rate (example)	1 l/min (ANR)

11-MSQA is identical to the high precision type and 11-MSQB is identical to the basic type.

Note) Please refer to "Pneumatic Clean Series" catalogue for further details.

Dimensions

Clean series products do not have a hollow axis.

Basic type
11-MSQB□A

High precision type
11-MSQA□A

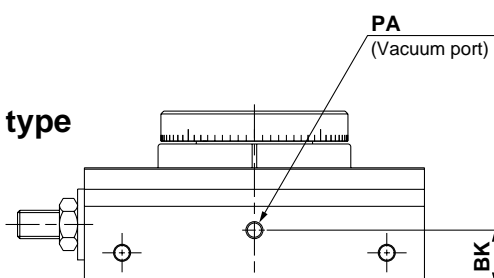

Size	BK	PA
1	5.3	M3
2	7.5	M3
3	9.5	M3
7	7	M5

Dimensions other than above are identical to the basic type and the high precision type.

Series MSQ

Rotation Direction and Rotation Angle

- The rotary table turns in the clockwise direction when the A port is pressurized, and in the counter-clockwise direction when the B port is pressurized.
- By adjusting the adjustment bolt, the rotation end can be set within the range shown in the drawing for the desired rotation angle.

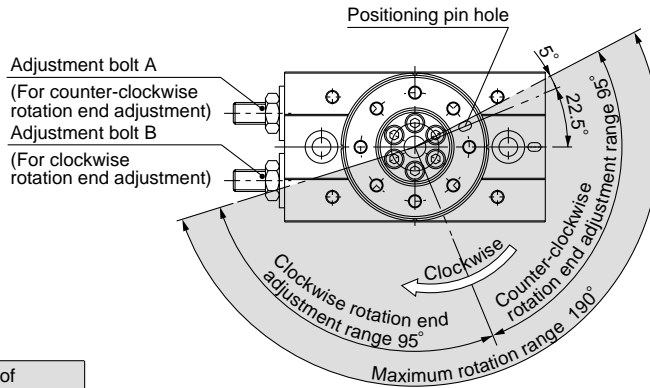
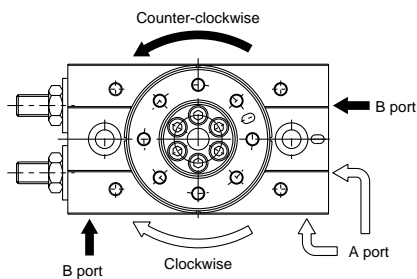

With adjust bolt, internal shock absorber

Size	Adjustment angle per rotation of angle adjustment screw
1	8.2°
2	10.0°
3	10.9°
7	10.2°

- Note) • The drawing shows the rotation range of the positioning pin hole.
 • The pin hole position in the drawing shows the counter-clockwise rotation end when the adjustment bolts A and B are tightened equally and the rotation is adjusted 180°.

Rotation Range Example

- Various rotation ranges are possible as shown in the drawings below using adjustment bolts A and B. (The drawings also show the rotation ranges of the positioning pin hole.)

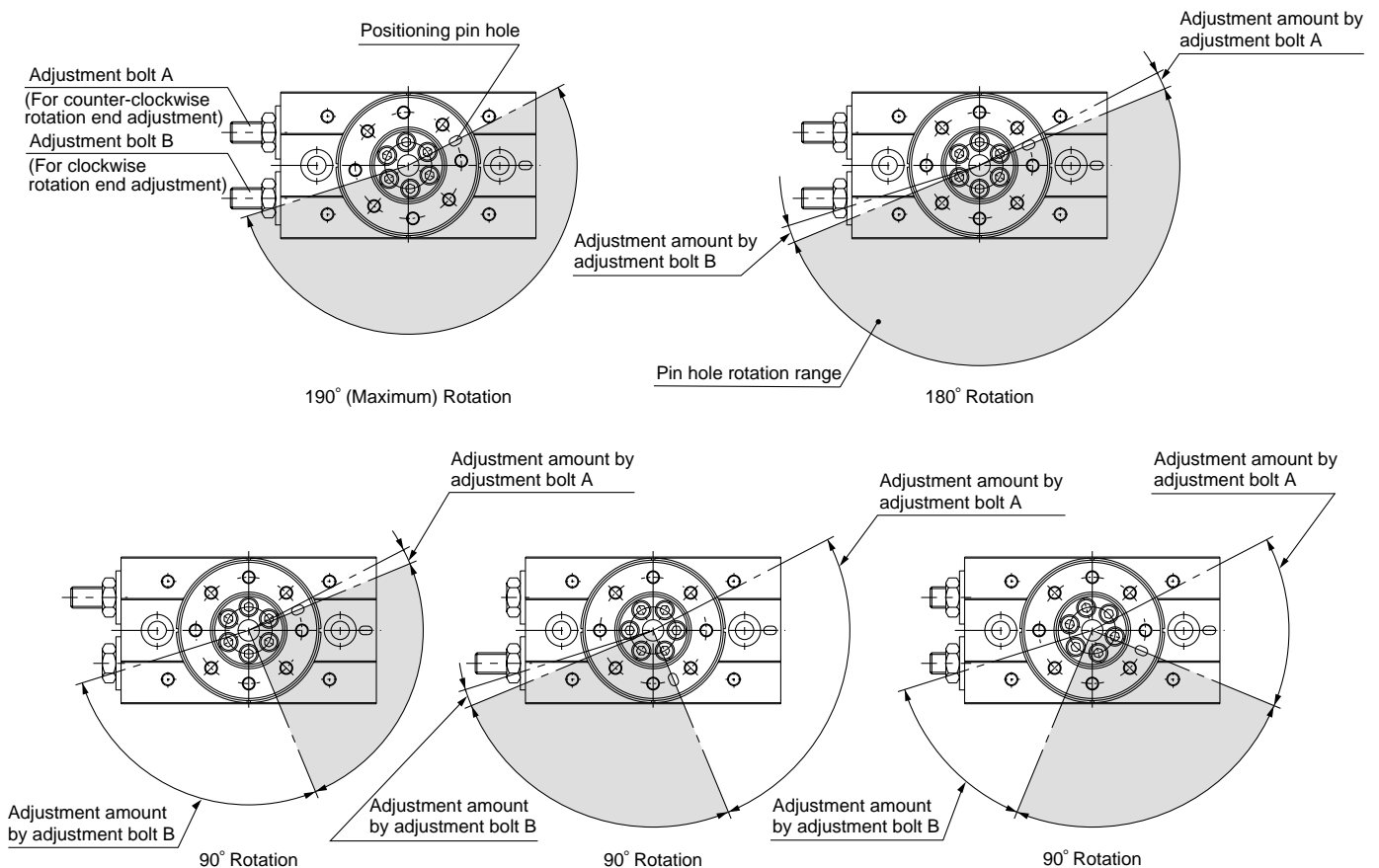

Construction

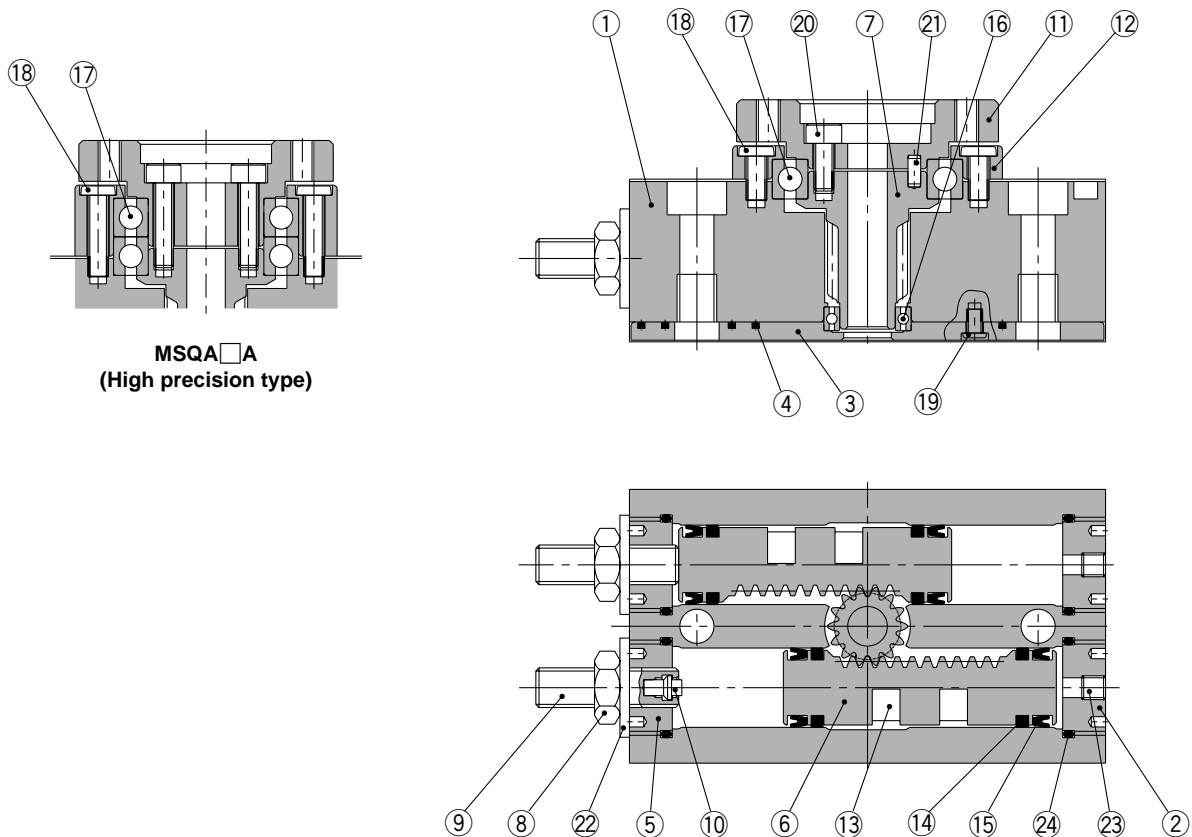

MSQA□A
(High precision type)

Component parts

No.	Description	Material
1	Body	Aluminium alloy
2	Cover	Aluminium alloy
3	Plate	Aluminium alloy
4	Seal	NBR
5	End cover	Aluminium alloy
6	Piston	Stainless steel
7	Pinion	Chrome molybdenum steel
8	Hexagon nut	Steel wire
9	Adjustment bolt	Steel wire
10	Cushion pad	Size: 3, 7 Rubber material
11	Table	Aluminium alloy
12	Bearing retainer	Aluminium alloy
13	Magnet	Magnetic material
14	Wear ring	Resin

No.	Description	Material
15	Piston seal	NBR
16	Deep groove ball bearing	Bearing steel
17	Basic type	Deep groove ball bearing
	High precision type	Special bearing
18	Round head Philips screw No.0	Basic type Size: 1 to 3
	Round head Philips screw	
	Round head Philips screw	High precision type
19	Round head Philips screw No.0	Steel wire
20	Hexagon socket head set bolt	Stainless steel
21	Parallel pin	Carbon steel
22	Seal washer	NBR
23	Hexagon socket head set screw	Stainless steel
24	O-ring	NBR

*23 The hexagon socket head set screws are tightened at different positions depending on the position of the connecting port.

Series MSQ

Dimensions/Size 1, 2, 3, 7

Basic type/MSQB□A

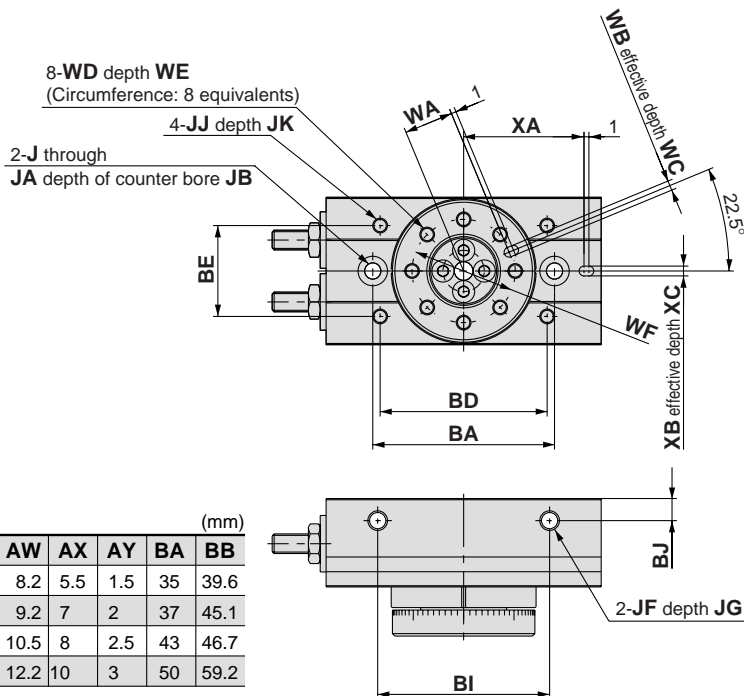
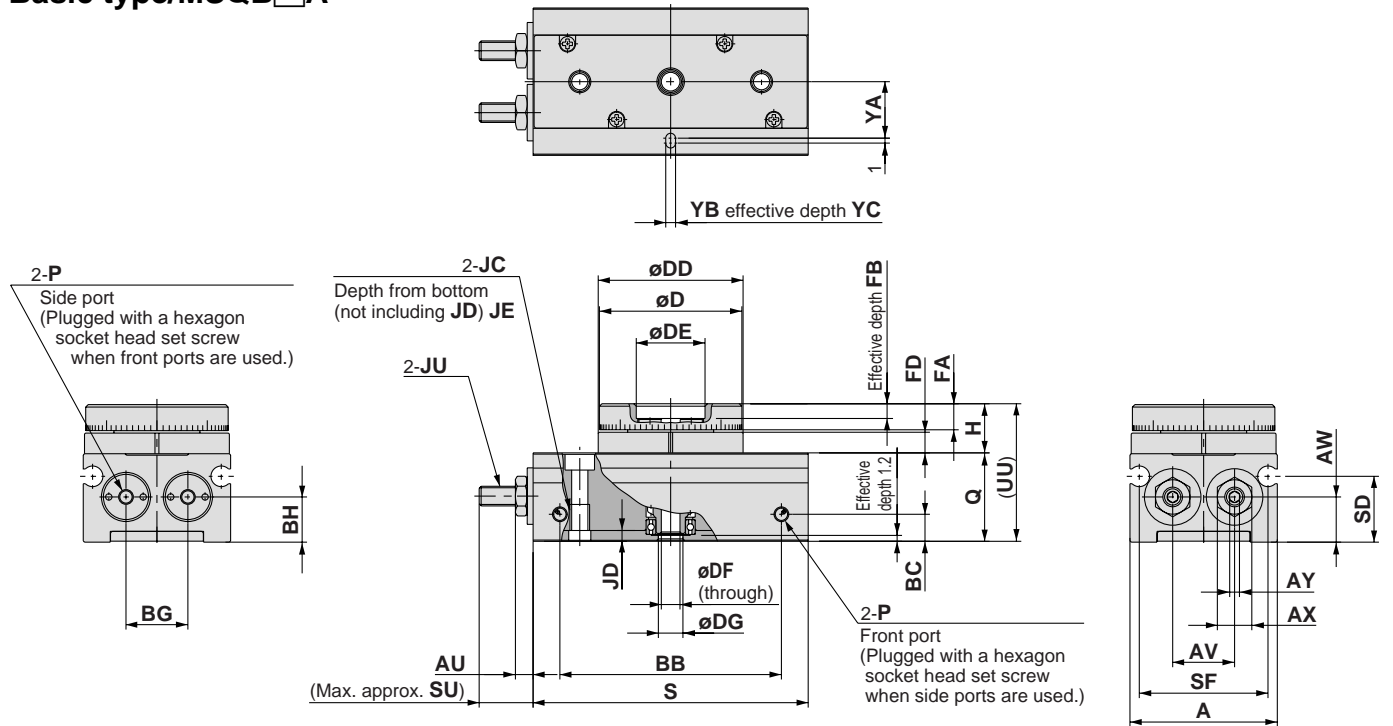

Size	DH	DI	DJ	DL	FE	HA	UV
1	27h8	27.5h8	14H8	4.5H8	8.2	13.5	29.5
2	29h8	29.5h8	14H8	5 H8	9.7	15.5	33.5
3	33h8	34h8	17H8	6 H8	9.7	15.5	36
7	39h8	40h8	20H8	7 H8	9.5	16.5	39.5

High precision type/MSQA□A

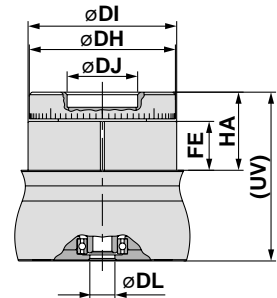

Size	A	AU	AV	AW	AX	AY	BA	BB
1	28	2.8	11	8.2	5.5	1.5	35	39.6
2	30	3.6	12.6	9.2	7	2	37	45.1
3	34.5	4.4	15.5	10.5	8	2.5	43	46.7
7	41	4.8	18.4	12.2	10	3	50	59.2

Size	BC	BD	BE	BG	BH	BI	BJ	D	DD	DE	DF	DG	FA	FB	FD	H	J	JA	JB	JC	JD	JE	JF	JG
1	4.5	32	17	11	8.2	30	4.5	27h9	27.5h9	14H9	3.5	4.5H9	4.8	2	3.7	9	3.3	6	3.5	M4	2.2	5.3	M4	4
2	5.5	34	18.5	12.6	9.2	35	4.5	29h9	29.5h9	14H9	3.8	5 H9	5.3	2.5	4.2	10	3.3	6	3.5	M4	2.2	5.3	M4	4
3	5.5	38	23	15.5	10.5	40	4.5	33h9	34 h9	17H9	5	6 H9	5.3	2.5	4.2	10	4.2	7.5	4.5	M5	2.5	6	M4	4
7	5.5	45	30	18.4	12.2	50	5	39h9	40 h9	20H9	6	7 H9	6.5	2.5	4.5	11.5	4.2	7.5	4.5	M5	2.5	6	M5	5

Size	JJ	JK	JU	P	Q	S	SD	SF	SU	UU	WA	WB	WC	WD	WE	WF	XA	XB	XC	YA	YB	YC
1	M3	3.5	M3	M3	16	50.5	10.8	24.4	9.4	25	9.5	2H9	2	M3	4.8	20	22.5	2H9	2	11	2H9	2
2	M3	3.5	M4	M3	18	56	13.4	26.2	11.3	28	10	2H9	2	M3	5.3	21	24.5	2H9	2	11.5	2H9	2
3	M3	3.5	M5	M3	20.5	60	15.2	31	11.8	30.5	12	2H9	2	M3	5.3	25	27	2H9	2	13.5	2H9	2
7	M4	4.5	M6	M5	23	73.5	15.4	37.4	14.9	34.5	14	3H9	3	M4	6.5	29	32.5	3H9	3	15.5	3H9	3

Rotary Table/Rack-and-Pinion Type Series *MSQ*

Size: 10, 20, 30, 50, 70, 100, 200

How to Order

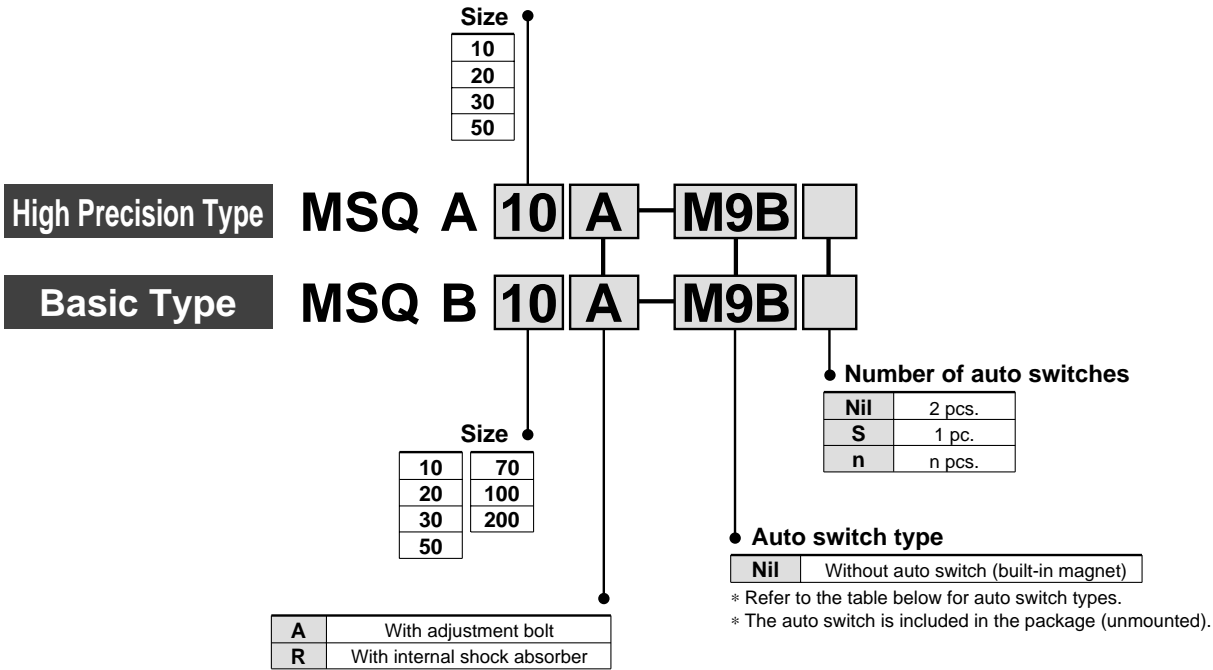

Applicable auto switches

Refer to pages 25 through 31 for detailed auto switch specifications.

Type	Special function	Electrical entry	Indicator light	Wiring (Output)	Load voltage			Auto switch type		Lead wire length (m)*			Applicable load	
					DC		AC	Perpendicular	In-line	0.5 (Nil)	3 (L)	5 (Z)		
					24 V	5 V, 12 V	100 V or less							
Reed switch	—	Grommet	No	2-wire	24 V	5 V, 12 V	100 V or less	A90V	A90	●	●	—	—	Relay, PLC
			Yes	3-wire (NPN equiv.)	—	5 V	—	A96V	A96	●	●	—	IC circuit	—
				2-wire	24 V	12 V	100 V	A93V	A93	●	●	—	—	Relay, PLC
Solid state switch	Diagnostic indication (2-colour display) Improved water resistance (2-colour display)	Grommet	Yes	3-wire (NPN)	24 V	5 V, 12 V	—	M9NV	M9N	●	●	○	—	Relay, PLC
				3-wire (PNP)				M9PV	M9P	●	●	○	—	
				2-wire				M9BV	M9B	●	●	○	—	
				3-wire (NPN)	M9NVV	M9NW	●	●	○	—	IC circuit			
				3-wire (PNP)	M9PWV	M9PW	●	●	○	—	IC circuit			
				2-wire	M9BVV	M9BW	●	●	○	—	—			
				—	M9BA**	—	●	○	—	—				

** Though it is possible to mount water resistant auto switch, the rotary table itself is not water resistance type.

* Lead wire length symbols: 0.5 m Nil (Example) M9N
3 m L (Example) M9NL
5 m Z (Example) M9NZ

* Solid state switches marked "○" are produced upon receipt of order.

Made to Order → Contact SMC.

- -50 Without indicator light
- -61 Flexible lead wire
- Pre-wire connector

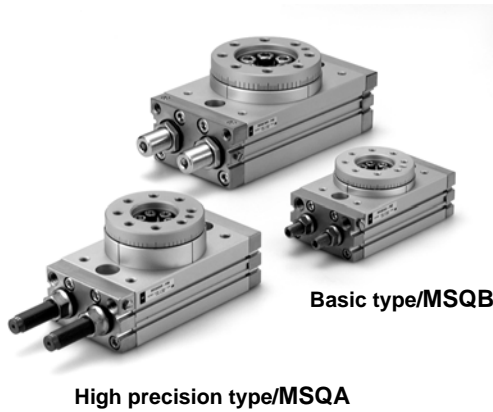

Specifications

Size	10	20	30	50	70	100	200
Fluid	Air (non-lube)						
Maximum operating pressure	With adjustment bolt	1 MPa					
	With internal shock absorber	0.6 MPa ^{Note 1)}					
Minimum operating pressure	Basic type	0.1 MPa					
	High precision type	0.2 MPa	0.1 MPa			—	
Ambient and fluid temperature	0 to 60°C (with no freezing)						
Cushion	With adjustment bolt	Rubber bumper					
	With internal shock absorber	Shock absorber					
	Shock absorber model	RBA0805-X692	RBA1006-X692	RBA1411-X692	RBA2015-X821	RBA2725-X821	
Angle adjustment range	0 to 190° ^{Note 2)}						
Maximum rotation	190°						
Cylinder bore size	ø15	ø18	ø21	ø25	ø28	ø32	ø40
Port size	End ports	M5		Rc 1/8			
	Side ports	M5					

Note 1) The maximum operating pressure of the actuator is restricted by the maximum allowable thrust of the shock absorber.

Note 2) Be careful if the rotation angle of a type with internal shock absorber is set below the value in the table below, the piston stroke will be smaller than the shock absorber's effective stroke, resulting in decreased energy absorption ability.

JIS symbol

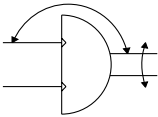

Size	10	20	30	50	70	100	200
Minimum rotation angle that will not allow decrease of energy absorption ability	52°	43°	40°	60°	71°	62°	82°

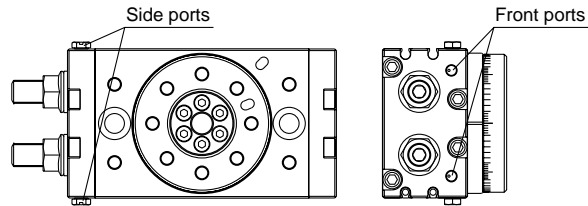

Allowable Kinetic Energy and Rotation Time Adjustment Range

Size	Allowable kinetic energy (mJ)		Rotation time adjustment range for stable operation (s/90°)	
	With adjustment bolt	With internal shock absorber	With adjustment bolt	With ^{Note 1)} internal shock absorber
10	7	39	0.2 to 1.0	0.2 to 0.7
20	25	116		
30	48	116		
50	81	294	0.2 to 1.5	0.2 to 1.0
70	240	1100		
100	320	1600	0.2 to 2.0	
200	560	2900	0.2 to 2.5	

Note 1) Be careful if a type with internal absorber is used below the minimum speed, the energy absorption ability will decrease drastically.

Weight

(g)

Size	10	20	30	50	70	100	200
Basic type	With adjustment bolt	530	990	1290	2080	2880	7580
	With internal shock absorber	540	990	1290	2100	2890	7650
High precision type	With adjustment bolt	560	1090	1410	2240	—	
	With internal shock absorber	570	1090	1410	2260	—	

Note) Values above do not include auto switch weights.

Rotation Direction and Rotation Angle

- The rotary table turns in the clockwise direction where the A port is pressurized, and in the counter-clockwise direction when the B port is pressurized.
- By adjusting the adjustment bolt, the rotation end can be set within the ranges shown in the drawing for the desired rotation angle.
- The rotation angle can also be set on a type with internal absorber.

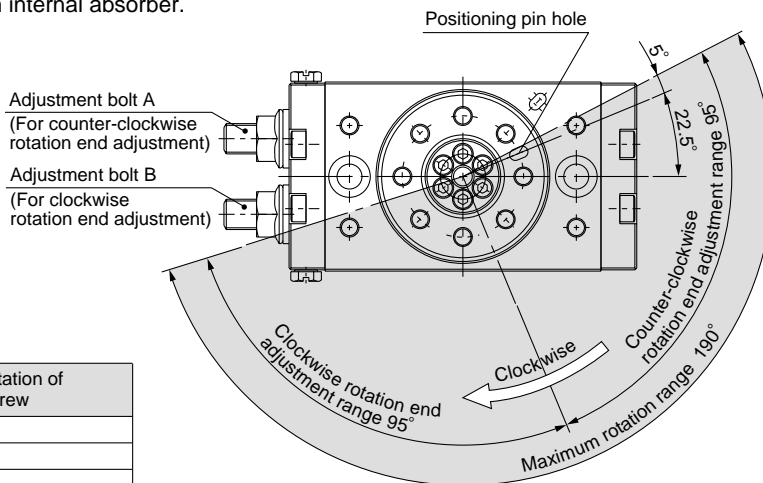
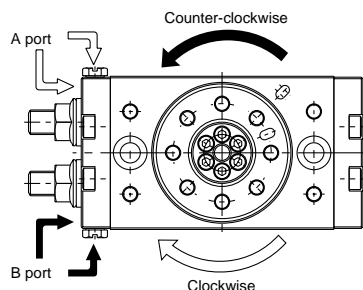

With adjust bolt, internal shock absorber

Size	Adjustment angle per rotation of angle adjustment screw
10	10.2°
20	7.2°
30	6.5°
50	8.2°
70	7.0°
100	6.1°
200	4.9°

- Note) • The drawing shows the rotation range of the positioning pin hole.
 • The pin hole position in the drawing shows the counter-clockwise rotation end when the adjustment bolts A and B are tightened equally and the rotation is adjusted 180°.

Rotation Range Example

- Various rotation ranges are possible as shown in the drawings below using adjustment bolts A and B. (The drawings also show the rotation ranges of the positioning pin hole.)
- The rotation angle can also be set on a type with inertial absorber.

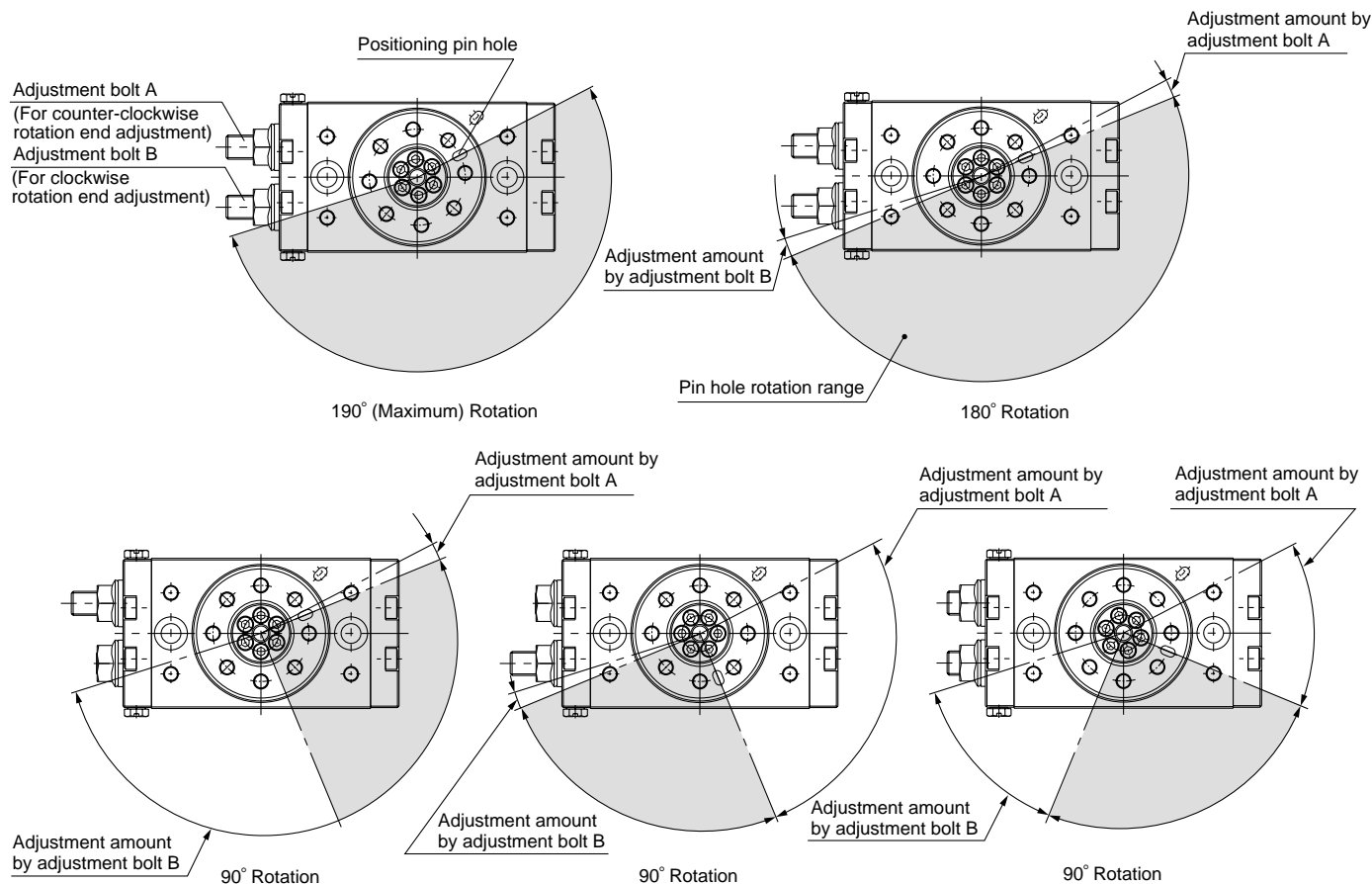

Series MSQ

Clean Series

Prevents dispersion of the particles generated inside of the product into the clean room by sucking them out of the vacuum port on the body side.

How to Order

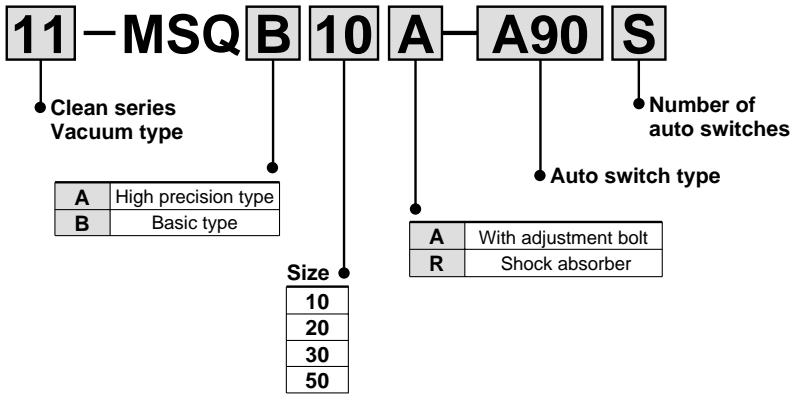

Specifications and Allowable Load

Particle generation grade	Grade 1 ^{Note 1)}
Suction flow rate (example)	1 ℓ/min (ANR)

11-MSQA is identical to the high precision type and 11-MSQB is identical to the basic type.

Note) Please refer to "Pneumatic Clean Series" catalogue for further details.



Dimensions

Clean series products do not have a hollow axis.

Basic type
 11-MSQB□A
 11-MSQB□R

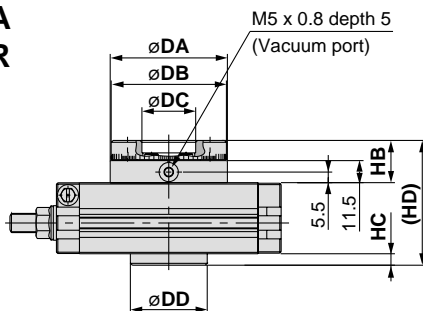

Size	DA(h9)	DB(h9)	DC(H9)	DD(h9)	HB	HC	HD
10	46	45	20	35	20	5	59
20	61	60	28	40	22	6	65
30	67	65	32	48	22	6	68
50	77	75	35	54	24	7	77

Dimensions other than above are identical to the basic type.

High precision type
 11-MSQA□A
 11-MSQA□R

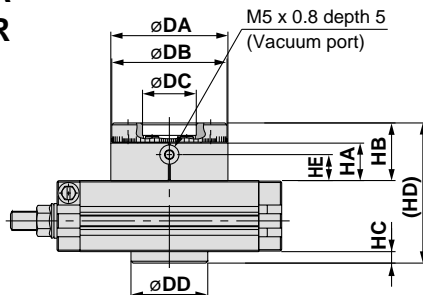

Size	DA(h8)	DB(h8)	DC(H8)	DD(h8)	HA	HB	HC	HD	HE
10	46	45	20	35	15.5	24	5	63	9.5
20	61	60	28	40	19.5	30	6	73	13.5
30	67	65	32	48	19.5	30	6	76	13.5
50	77	75	35	54	21.5	34	7	87	15.5

Dimensions other than above are identical to the high precision type.

Construction

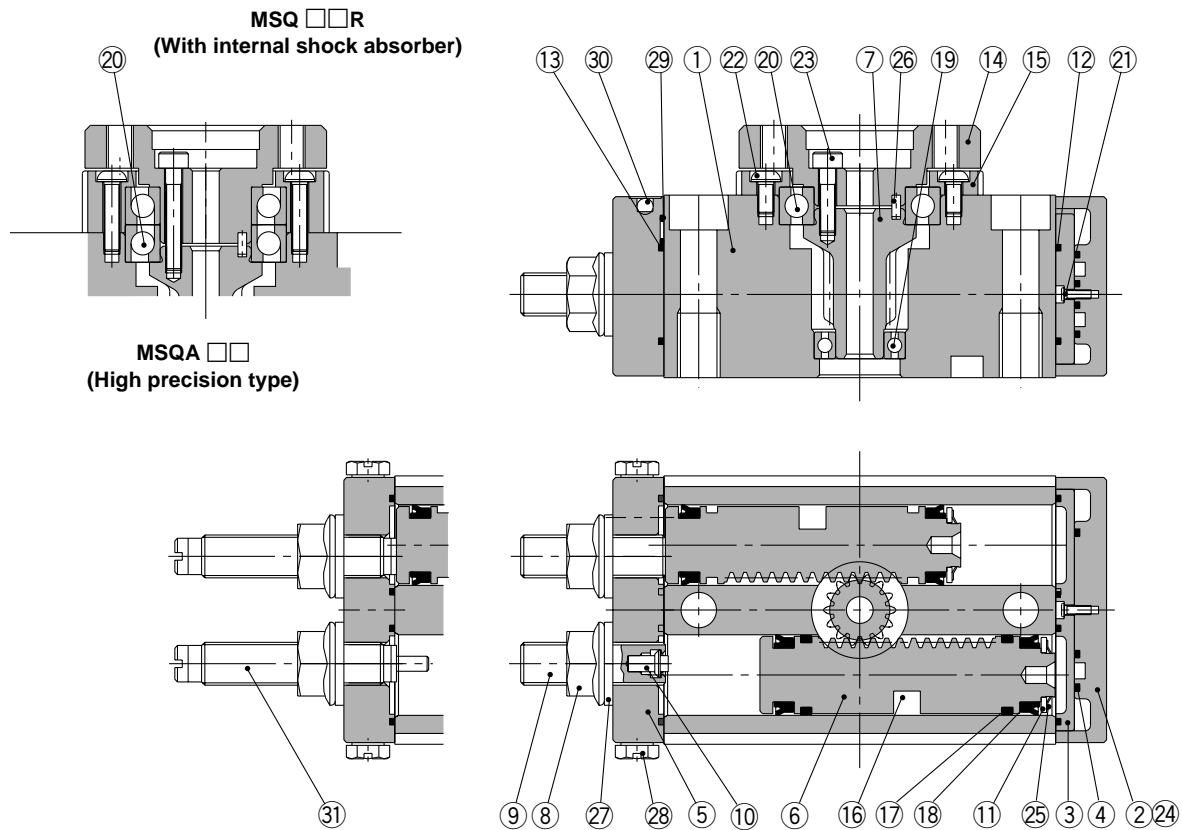

Parts list

No.	Description	Material
1	Body	Aluminium alloy
2	Cover	Aluminium alloy
3	Plate	Aluminium alloy
4	Seal	NBR
5	End cover	Aluminium alloy
6	Piston	Stainless steel
7	Pinion	Chrome molybdenum steel
8	Hexagon nut with flange	Steel wire
	Hexagon nut	
9	Adjustment bolt	Chrome molybdenum steel
10	Cushion pad	Rubber material
11	Seal retainer	Aluminium alloy
12	Gasket	NBR
13	Gasket	NBR
14	Table	Aluminium alloy
15	Bearing retainer	Aluminium alloy
16	Magnet	Magnetic material
17	Wear ring	Resin
18	Piston seal	NBR

No.	Description	Material
19	Deep groove ball bearing	Bearing steel
	Needle bearing	
20	Deep groove ball bearing	Bearing steel
	Angular contact ball bearing	
21	Round head philips screw	Steel wire
	Round head philips screw	
22	Low head cap screw	Chrome molybdenum steel
	Hexagon socket head set bolt	
23	Hexagon socket head set bolt	Stainless steel
24	Hexagon socket head set bolt	Carbon steel
	Hexagon socket head set bolt	
25	CS type snap ring	Spring steel
26	Parallel pin	Carbon steel
	Parallel key	
27	Seal washer	NBR
28	Plug	Brass
29	O-ring	NBR
30	Steel balls	Stainless steel
31	Shock absorber	—

Replacement parts

Description	Kit no.							Note
	10	20	30	50	70	100	200	
Seal kit	KT-MSQ10	KT-MSQ20	KT-MSQ30	KT-MSQ50	KT-MSQ70	KT-MSQ100	KT-MSQ200	A set of above numbers ④, ⑫, ⑬, ⑰, ⑱ and ⑳

Series MSQ

Dimensions/Size 10, 20, 30, 50

Basic type/MSQB□A

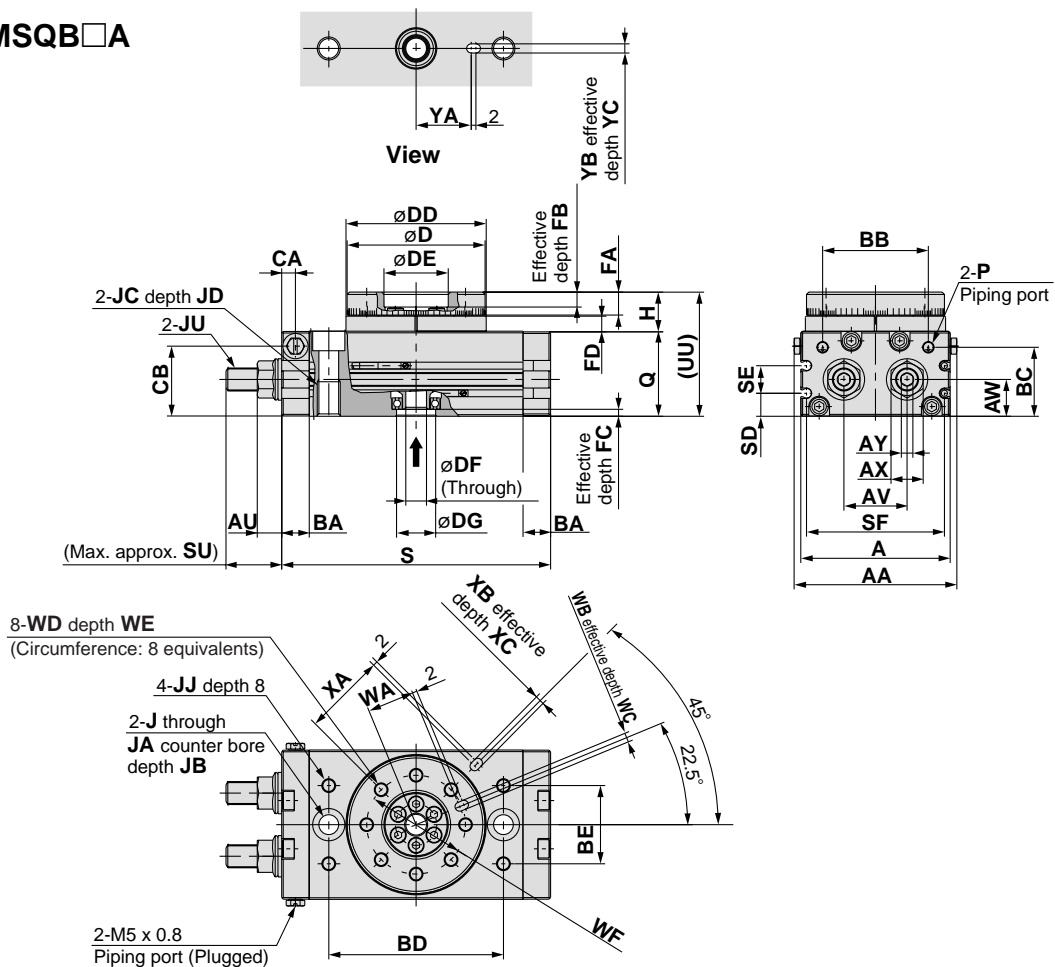

With internal shock absorber
MSQA□R
MSQB□R

High precision type
MSQA□A/With adjustment bolt
MSQA□R/With internal shock absorber

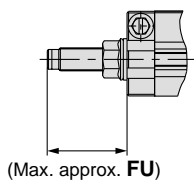

Size	FU (mm)
10	31.5
20	34.7
30	34.7
50	51.7

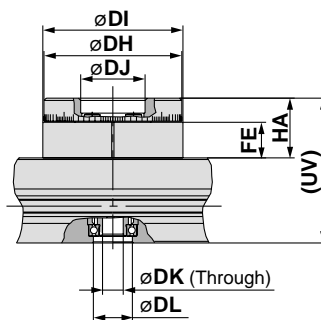

Size	DH	DI	DJ	DK	DL	FE	HA	UV
10	45h8	46h8	20H8	5	15H8	10	18.5	52.5
20	60h8	61h8	28H8	9	17H8	15.5	26	63
30	65h8	67h8	32H8	9	22H8	16.5	27	67
50	75h8	77h8	35H8	10	26H8	17.5	30	76

Size	AA	A	AU	AV	AW	AX	AY	BA	BB	BC	BD	BE	CA	CB	D	DD	DE	DF	DG	FA	FB	FC	FD	H	J	JA	JB
10	55.4	50	8.6	20	15.5	12	4	9.5	34.5	27.8	60	27	4.5	28.5	45h9	46h9	20H9	5	15H9	8	4	3	4.5	13	6.8	11	6.5
20	70.8	65	10.6	27.5	16	14	5	12	46	30	76	34	6	30.5	60h9	61h9	28H9	9	17H9	10	6	2.5	6.5	17	8.6	14	8.5
30	75.4	70	10.6	29	18.5	14	5	12	50	32	84	37	6.5	33.5	65h9	67h9	32H9	9	22H9	10	4.5	3	6.5	17	8.6	14	8.5
50	85.4	80	14	38	22	19	6	15.5	63	37.5	100	50	10	37.5	75h9	77h9	35H9	10	26H9	12	5	3	7.5	20	10.5	18	10.5

Size	JC	JD	JJ	JU	P	Q	S	SD	SE	SF	SU	UU	WA	WB	WC	WD	WE	WF	XA	XB	XC	YA	YB	YC
10	M8	12	M5	M8 x 1	M5	34	92	9	13	45	17.7	47	15	3H9	3.5	M5	8	32	27	3H9	3.5	19	3H9	3.5
20	M10	15	M6	M10 x 1	M5	37	117	10	12	60	25	54	20.5	4H9	4.5	M6	10	43	36	4H9	4.5	24	4H9	4.5
30	M10	15	M6	M10 x 1	Rc 1/8	40	127	11.5	14	65	25	57	23	4H9	4.5	M6	10	48	39	4H9	4.5	28	4H9	4.5
50	M12	18	M8	M14 x 1.5	Rc 1/8	46	152	14.5	15	75	31.4	66	26.5	5H9	5.5	M8	12	55	45	5H9	5.5	33	5H9	5.5

Dimensions/Size 70, 100, 200

Basic type/MSQB□A

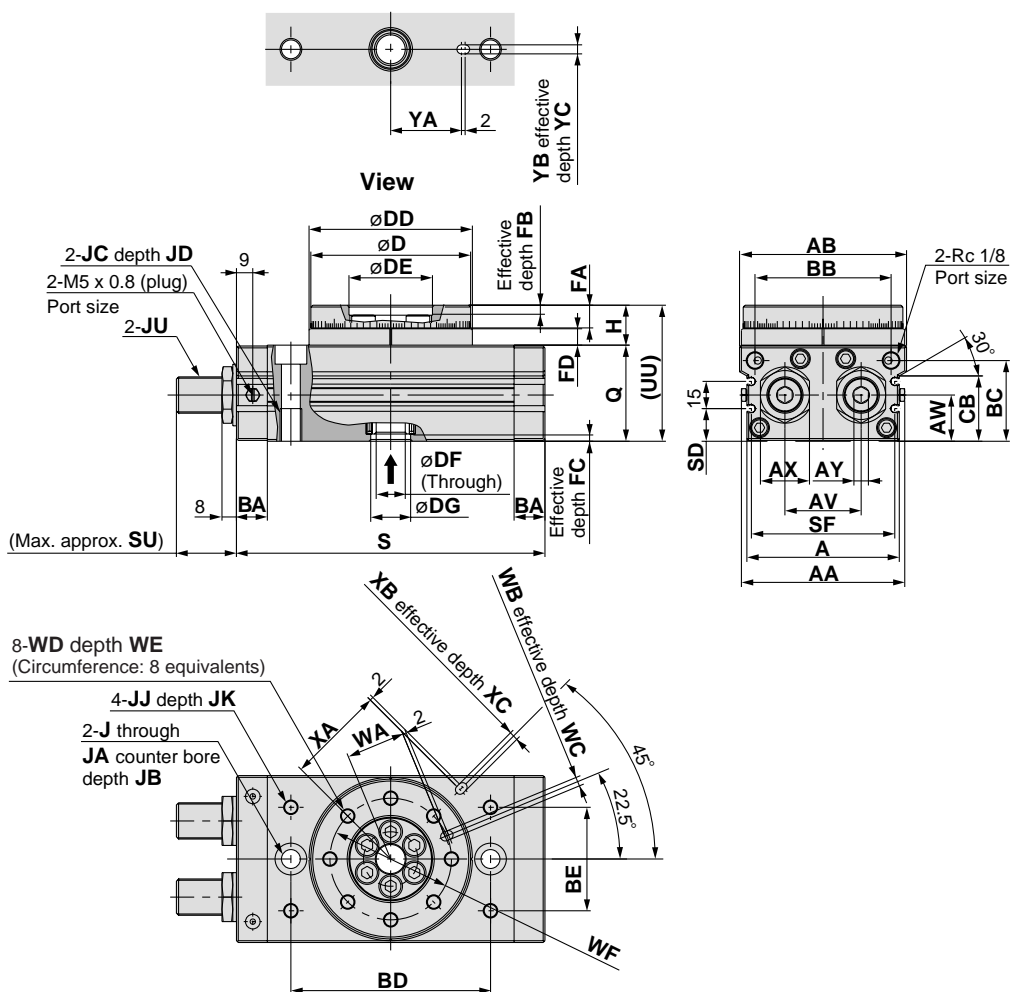

With shock absorber MSQB□R

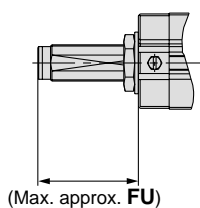

Size	FU
70	55.4
100	55.5
200	74.7

Size	AA	AB	A	AV	AW	AX	AY	BA	BB	BC	BD	BE	CB	D	DD	DE	DF	DG	FA	FB	FC	FD	H	J	JA	JB
70	90	92	84	42	25.5	27	8	17	75	44.5	110	57	36	88h9	90h9	46H9	16	22H9	12.5	5	3.5	9	22	10.4	17.5	10.5
100	101	102	95	50	29.5	27	8	17	85	50.5	130	66	42	98h9	100h9	56H9	19	24H9	14.5	6	3.5	12	27	10.4	17.5	10.5
200	119	120	113	60	36.5	36	10	24	103	65.5	150	80	57	116h9	118h9	64H9	24	32H9	16.5	9	5.5	15	32	14.2	20	12.5

Size	JC	JD	JJ	JK	JU	Q	S	SD	SF	SU	UU	WA	WB	WC	WD	WE	WF	XA	XB	XC	YA	YB	YC
70	M12	18	M8	10	M20 x 1.5	53	170	18	79	34.2	75	32.5	5H9	5.5	M8	12.5	67	54	5H9	3.5	39	5H9	3.5
100	M12	18	M8	10	M20 x 1.5	59	189	22	90	34.3	86	37.5	6H9	6.5	M10	14.5	77	59	6H9	4.5	49	6H9	4.5
200	M16	25	M12	13	M27 x 1.5	74	240	29	108	40.2	106	44	8H9	8.5	M12	16.5	90	69	8H9	4.5	54	8H9	6.5

Rotary Table/Rack-and-Pinion Type

Series MSQ

With External Shock Absorber

Size: 10, 20, 30, 50

How to Order

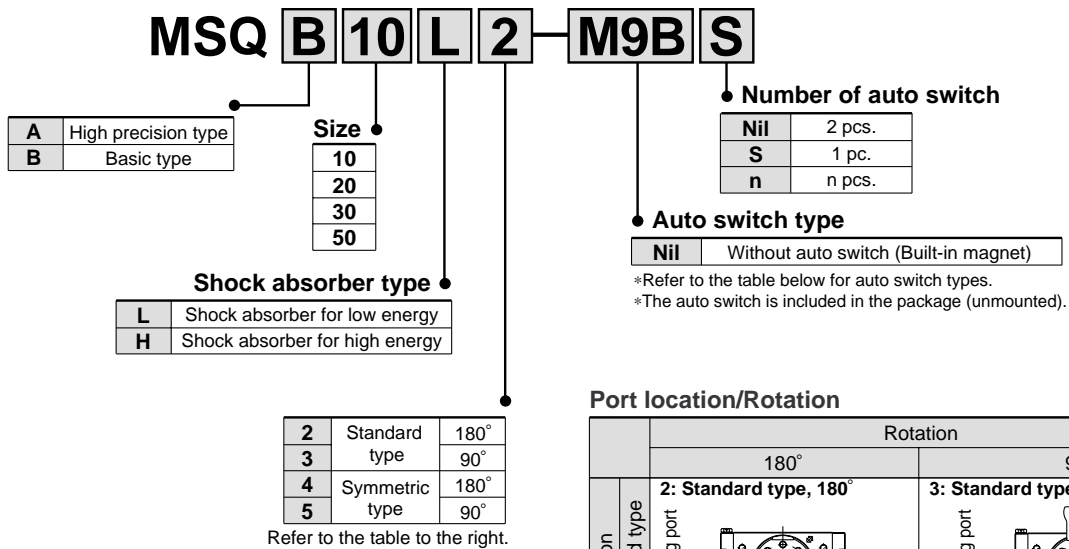

Port location/Rotation

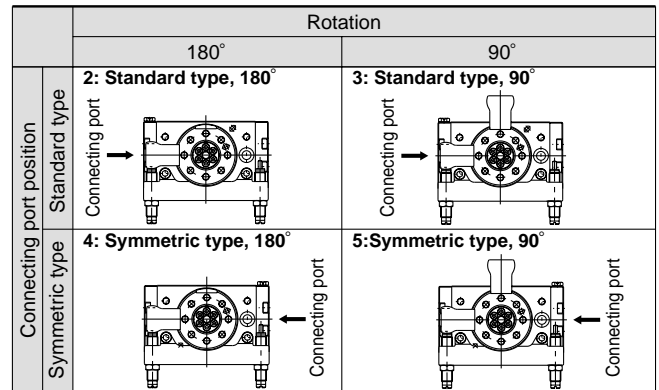

Applicable auto switches

Refer to pages 25 through 31 for detailed auto switch specifications.

Type	Special function	Electrical entry	Indicator light	Wiring (Output)	Load voltage			Auto switch type		Lead wire length (m)*			Applicable load	
					DC		AC	Perpendicular	In-line	0.5 (Nil)	3 (L)	5 (Z)		
					24 V	5 V, 12 V	100 V or less						A90V	A90
Reed switch	-	Grommet	No	2-wire	24 V	5 V, 12 V	100 V or less	A90V	A90	●	●	-	IC circuit	Relay, PLC
			Yes	3-wire (NPN equiv.)	-	5 V	-	A96V	A96	●	●	-		
			Yes	2-wire	24 V	12 V	100 V	A93V	A93	●	●	-	-	Relay, PLC
Solid state switch	-	Grommet	Yes	3-wire (NPN)	24 V	5 V, 12 V	-	M9NV	M9N	●	●	○	IC circuit	Relay, PLC
				3-wire (PNP)				M9PV	M9P	●	●	○		
				2-wire				M9BV	M9B	●	●	○	-	
				Diagnostic indication (2-colour display)	3-wire (NPN)	5 V, 12 V	-	M9NWV	M9NW	●	●	○	IC circuit	
				3-wire (PNP)	M9PWV			M9PW	●	●	○	-		
				Improved water resistance (2-colour display)	2-wire	12 V	M9BWV	M9BW	●	●	○	-		
				-	-	-	-	M9BA**	-	●	○	-		

** Though it is possible to mount water resistant auto switch, the rotary table itself is not water resistance type.

* Lead wire length symbols: 0.5 m ····· Nil (Example) M9N
3 m ····· L (Example) M9NL
5 m ····· Z (Example) M9NZ

*Solid state switches marked "O" are produced upon receipt of order.

Made to Order → Contact SMC.

- 50 Without indicator light
- 61 Flexible lead wire
- Pre-wire connector

Specifications

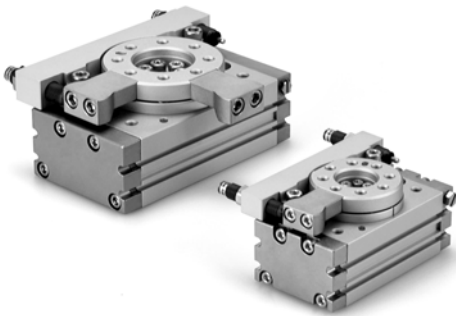

Size	10	20	30	50
Fluid	Air (non-lube)			
Maximum operating pressure	1 MPa			
Minimum operating pressure	0.2 MPa			
Ambient and fluid temperature	0 to 60°C (with no freezing)			
Cushion	Shock absorber			
Shock absorber type	For low energy	RB0805	RB1006	RB1411
	For high energy	RB0806	RB1007	RB1412
Rotation	90°, 180°			
Angle adjusting range	Each rotation end ±3°			
Cylinder bore size	ø15	ø18	ø21	ø25
Port size	End ports	M5		Rc 1/8
	Side ports	M5		

JIS symbol

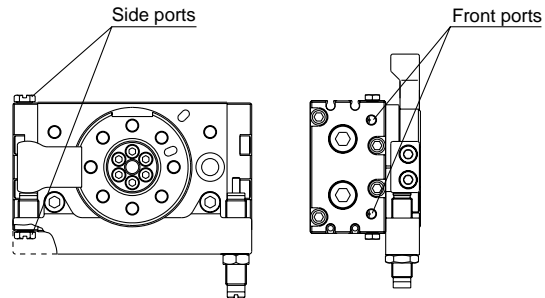
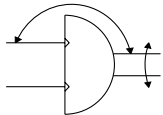

Allowable Kinetic Energy and Rotation Time Adjustment Range

Size	Allowable kinetic energy (mJ)		Rotation time adjustment range for stable operation (s/90°)
	Shock absorber for low energy	Shock absorber for high energy	
10	161	231	0.2 to 1.0 ^{Note)}
20	574	1060	
30	805	1210	
50	1310	1820	

Note) Values above indicate the time between the start of rotation and the deceleration caused by the shock absorber. Although the time required by the rotary table to reach the rotation end after deceleration differs depending on the operating conditions (inertial moment of the load, rotation speed and operating pressure), approximately 0.2 to 2 seconds are required. The range of angles within which the shock absorber operates is between the rotation end and the values shown below.

Size	10	20	30	50
For low energy	7.1°	6.9°	6.2°	9.6°
For high energy	8.6°	8.0°	7.3°	10.5°

Weight

(g)

Size		10	20	30	50
Basic type	90° specification	630	1200	1520	2480
	180° specification	600	1140	1450	2370
High precision type	90° specification	700	1390	1750	2810
	180° specification	670	1340	1680	2690

Note) Values above do not include auto switch weights.

Series MSQ

Rotation Direction and Rotation Angle

- The rotary table turns in the clockwise direction where the A port is pressurized, and in the counter-clockwise direction when the B port is pressurized.
- By adjusting the shock absorber, the rotation end can be set within the ranges shown in the drawing.

Standard type

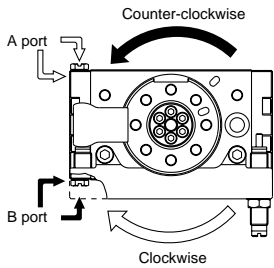

For 180°

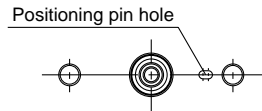
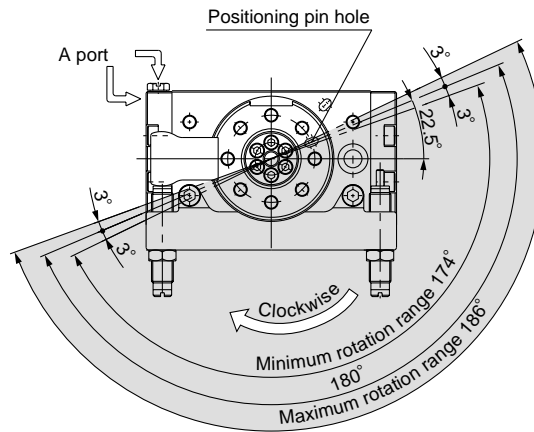

Position of bottom positioning pin hole

For 90°

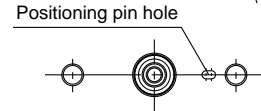
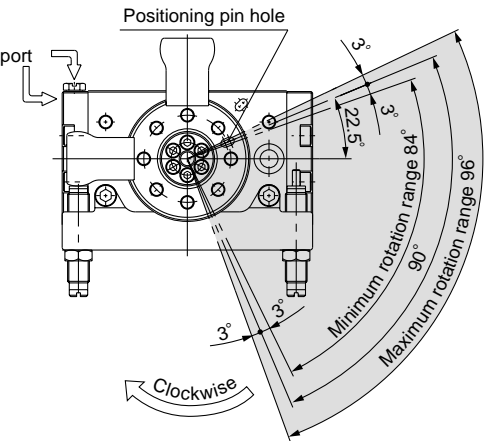

Position of bottom positioning pin hole

Symmetric type

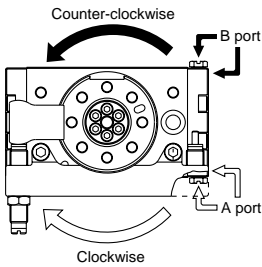

For 180°

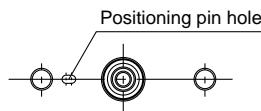
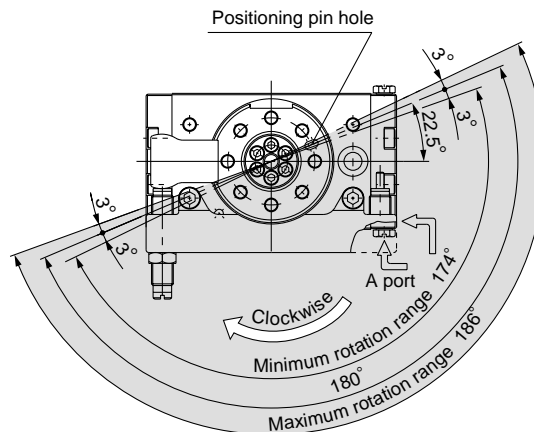

Position of bottom positioning pin hole

For 90°

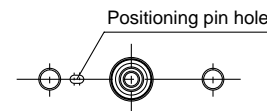
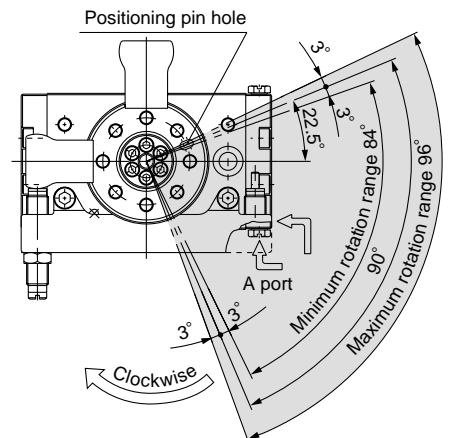

Position of bottom positioning pin hole

With external shock absorber

Size	Adjustment angle per rotation of angle adjustment screw
10	1.4°
20	1.2°
30	1.1°
50	1.3°

Note) · The drawings show the rotation range for the top positioning pin hole of the table.

· The pin hole position in the drawing shows the counter-clockwise rotation end when the shock absorbers are tightened equally and the rotation is adjusted to 180° and 90°.

Construction

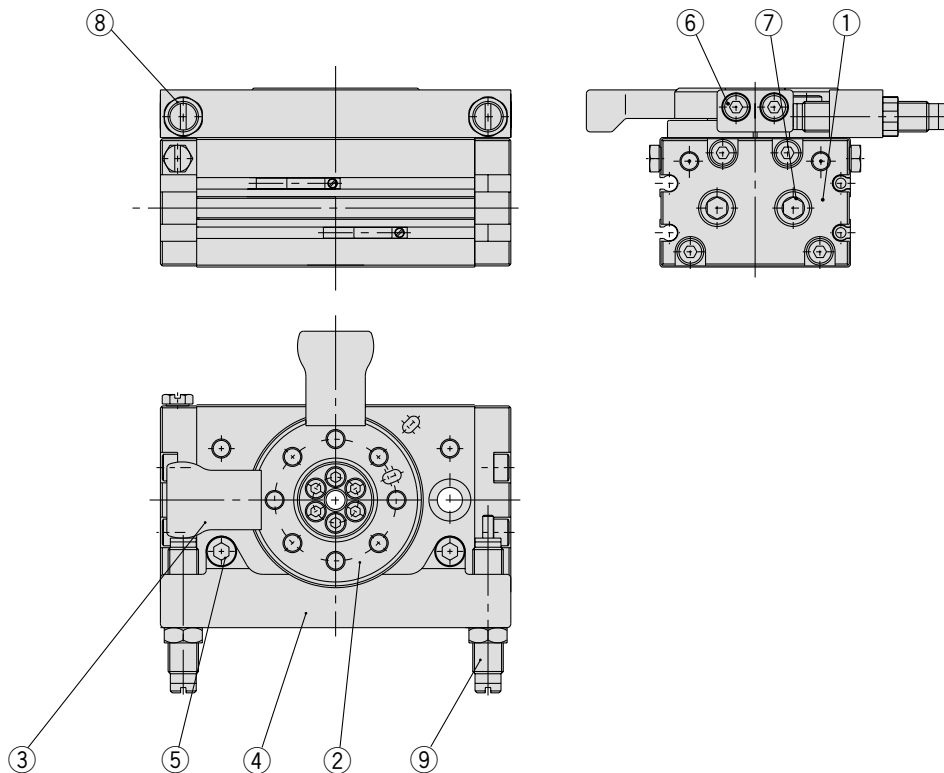

Component parts

No.	Description	Material
1	End cover	Aluminium alloy
2	Table	Aluminium alloy
3	Arm	Chrome molybdenum steel
4	Shock absorber holder	Aluminium alloy
5	Hexagon socket head set bolt	Stainless steel
6	Hexagon socket head set bolt	Stainless steel
7	Taper plug	Steel wire
8	Hexagon nut	Steel wire
9	Shock absorber	—

Replacement parts

Description	Kit no.				Note
	10	20	30	50	
Seal kit	P523010-6	P523020-6	P523030-6	P523040-6	Seal washer ⑰ is excluded from the kit contents described on page 16.

Proper Auto Switch Mounting Position at Rotation End

• Size: 1 to 7

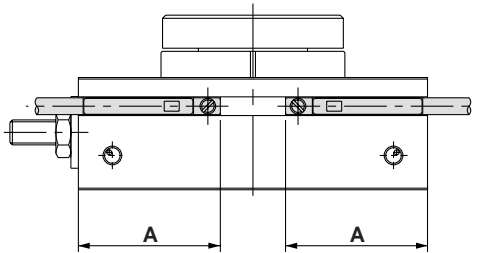

When D-M9 and M9 are used

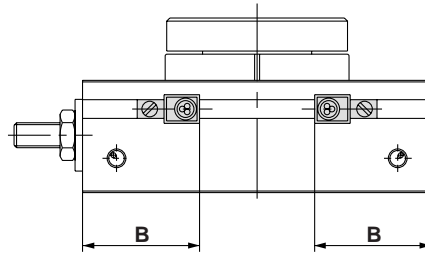

When D-F8 is used

Size	Rotation	Solid state switch								
		D-M9□W			D-M9□			D-F8□		
		A	Operating angle θ m	Hysteresis angle	A	Operating angle θ m	Hysteresis angle	B	Operating angle θ m	Hysteresis angle
1	190°	20.9	40°	10°	20.9	55°	10°	16.9	20°	10°
2	190°	22.8	35°	10°	22.8	45°	10°	18.8	20°	10°
3	190°	24.4	30°	10°	24.4	40°	10°	20.4	15°	10°
7	190°	28.7	25°	10°	28.7	40°	10°	24.7	15°	10°

Operating angle θ m: Value of the operating range Lm of a single auto switch converted to an axial rotation angle.
 Hysteresis angle : Value of auto switch hysteresis converted to an angle.

• Size: 10 to 200

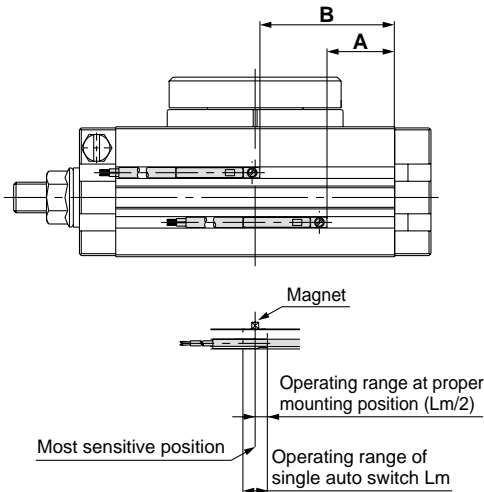

Size	Rotation	Reed switch				Solid state switch							
		D-A9□, D-A9□V				D-M9□W, D-M9□WV, D-M9BAL				D-M9□			
		A	B	Operating angle θ m	Hysteresis angle	A	B	Operating angle θ m	Hysteresis angle	A	B	Operating angle θ m	Hysteresis angle
10	190°	17	36	90°	10°	21	40	90°	10°	21	40	60°	10°
20	190°	23	50	80°	10°	27	54	80°	10°	27	54	50°	10°
30	190°	27	66	65°	10°	31	60	65°	10°	31	60	50°	10°
50	190°	33	68	50°	10°	37	72	50°	10°	37	72	40°	10°
70	190°	37	78	45°	10°	41	82	45°	10°	41	82	40°	10°
100	190°	44	91	40°	10°	48	95	40°	10°	48	95	30°	10°
200	190°	57	115	35°	10°	61	119	35°	10°	61	119	20°	10°

Operating angle θ m: Value of the operating range Lm of a single auto switch converted to an axial rotation angle.
 Hysteresis angle : Value of auto switch hysteresis converted to an angle.

Series MSQ

Auto Switch Specifications

Auto Switch Common Specifications

Type	Reed switch	Solid state switch
Leakage current	None	3-wire: 100 μ A or less, 2-wire: 0.8 mA or less
Operating time	1.2 ms	1 ms or less
Impact resistance	300 m/s ²	1000 m/s ²
Insulation resistance	50 M Ω or more at 500 VDC (Between lead wire and case)	
Withstand voltage	1000 VAC for 1 min. (Between lead wire and case)	1000 VAC for 1 min. (Between lead wire and case)
Ambient temperature	-10 to 60°C	
Enclosure	IEC529 standard IP67, JISC0920 watertight construction	

Lead Wire Length

Lead wire length indication

(Example) D-M9P **L**

Lead wire length

Nil	0.5 m
L	3 m
Z	5 m

Note 1) Lead wire length Z: Auto switch applicable to 5 m length
Solid state switch: All types are produced upon receipt of order (standard procedure).

Note 2) For solid state switches with flexible lead wire specification, add "-61" at the end of the lead wire length.

Contact Protection Boxes/CD-P11, CD-P12

<Applicable switches>

D-A9/A9□V

The above auto switches do not have internal contact protection circuits.

1. The operating load is an induction load.
2. The length of wiring to the load is 5 m or more.
3. The load voltage is 100 VAC.

Use a contact protection box in any of the above situations.

The life of the contacts may otherwise be reduced. (They may stay ON all the time.)

Specifications

Part number	CD-P11		CD-P12
Load voltage	100 VAC	200 VAC	24 VDC
Maximum load current	25 mA	12.5 mA	50 mA

* Lead wire length — Switch connection side 0.5 m
Load connection side 0.5 m



Internal circuits

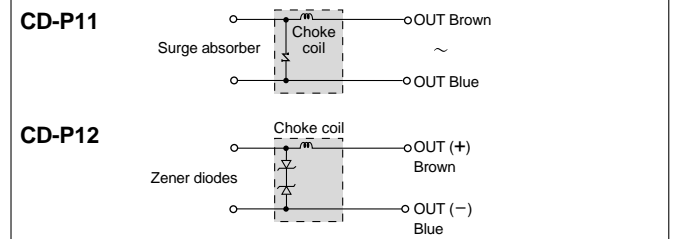

Dimensions

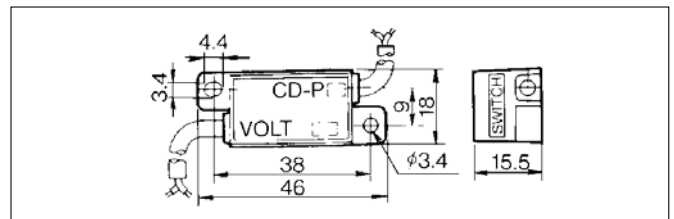

Connection

To connect a switch to a contact protection box, connect the lead wire from the side of the contact protection box marked SWITCH to the lead wire coming out of the switch. Furthermore, the switch unit should be kept as close as possible to the contact protection box, with a lead wire length of no more than 1 meter between them.

Auto Switch Connections and Examples

Basic Wiring

Solid state 3-wire, NPN

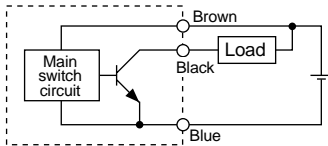

Solid state 3-wire, PNP

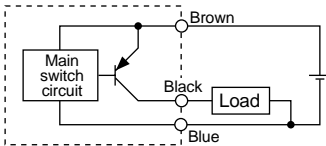

2-wire <Solid state switch>

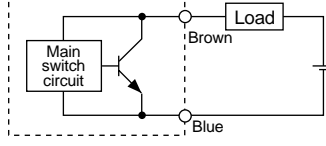

2-wire <Reed switch>

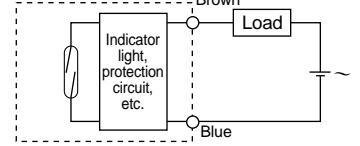

(Power supplies for switch and load are separate.)

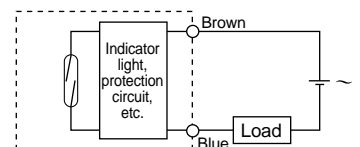
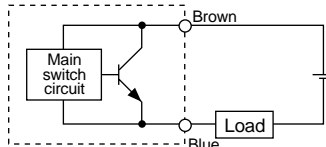
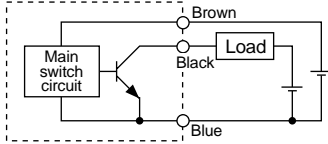

Examples of Connection to PLC (Programmable Logic Controller)

Sink input specifications

3-wire, NPN

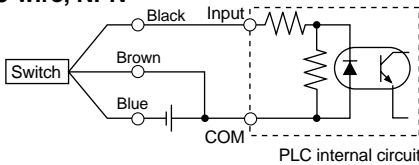

2-wire

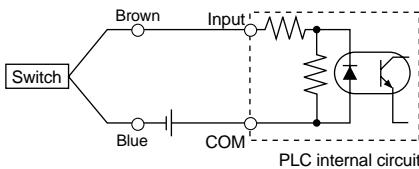

Source input specifications

3-wire, PNP

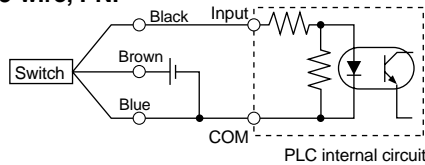

2-wire

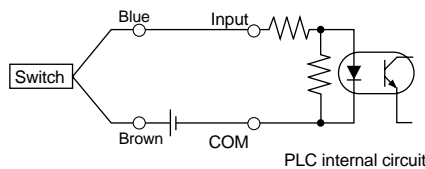

Connect according to the applicable PLC input specifications, as the connection method will vary depending on the PLC input specifications.

Connection Examples for AND (Series) and OR (Parallel)

3-wire AND connection for NPN output (using relays)

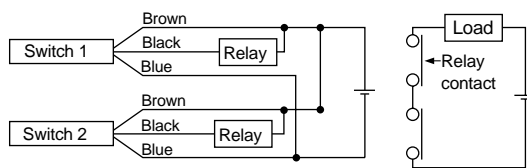

AND connection for NPN output (performed with switches only)

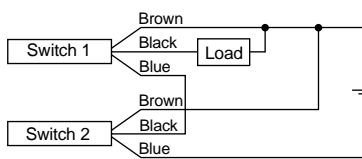

OR connection for NPN output

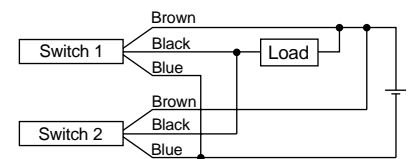

The indicator lights will light up when both switches are turned ON.

2-wire with 2 switch AND connection

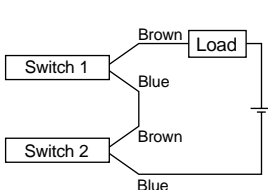

When two switches are connected in series, a load may malfunction because the load voltage will decline when in the ON state. The indicator lights will light up if both of the switches are in the ON state.

2-wire with 2 switch OR connection

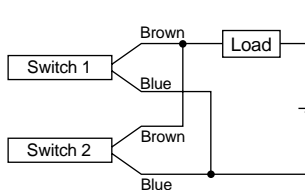

<Solid state switch> When two switches are connected in parallel, malfunction may occur because the load voltage will increase when in the OFF state.

<Reed switch> Because there is no current leakage, the load voltage will not increase when turned OFF. However, depending on the number of switches in the ON state, the indicator lights may sometimes get dark or not light up, because of dispersion and reduction of the current flowing to the switches.

$$\begin{aligned} \text{Load voltage at ON} &= \text{Power supply voltage} - \text{Residual voltage} \times 2 \text{ pcs.} \\ &= 24 \text{ V} - 4 \text{ V} \times 2 \text{ pcs.} \\ &= 16 \text{ V} \end{aligned}$$

Example: Power supply is 24 VDC
Voltage drop in switch is 4 V

$$\begin{aligned} \text{Load voltage at OFF} &= \text{Leakage current} \times 2 \text{ pcs.} \times \text{Load impedance} \\ &= 1 \text{ mA} \times 2 \text{ pcs.} \times 3 \text{ k}\Omega \\ &= 6 \text{ V} \end{aligned}$$

Example: Load impedance is 3 kΩ
Leakage current from switch is 1 mA

Reed Switches: Direct Mounting Type

D-A90(V), D-A93(V), D-A96(V)



For details about certified products conforming to international standards, visit us at www.smcworld.com.

Grommet
Electrical entry: In-line



⚠ Caution

Precautions

- When securing the switch, be sure to use the fixing screws attached to the auto switch body. The switch may be damaged if screws other than specified ones are used.

Auto Switch Internal Circuits

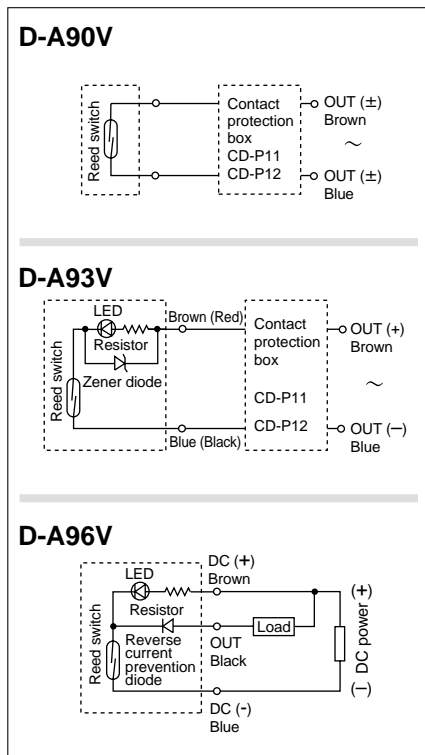

- Note) ① The operating load is the induction load.
 ② The wiring length to the load is 5 m or more.
 ③ The load voltage is 100 VAC

Under any of the above conditions, the life time of the contact may be shortened. Please use a contact protection box. (Please refer to page 19 for more information on the contact protection box.)

Auto Switch Specifications

PLC: Programmable Logic Controller

D-A90, D-A90V (without indicator light)			
Auto switch part no.	D-A90, D-A90V		
Applicable load	IC circuit, Relay, PLC		
Load voltage	24 V _{DC} ^{AC} or less	48 V _{DC} ^{AC} or less	100 V _{DC} ^{AC} or less
Max. load current	50 mA	40 mA	20 mA
Contact protection circuit	None		
Internal resistance	1 Ω or less (Includes the lead wire length of 3 m)		
D-A93, D-A93V, D-A96, D-A96V (with indicator light)			
Auto switch part no.	D-A93, D-A93V		D-A96, D-A96V
Applicable load	Relay, PLC		IC circuit
Load voltage	24 VDC	100 VAC	4 to 8 VDC
Load current range and Max. load current	5 to 40 mA	5 to 20 mA	20 mA
Contact protection circuit	None		
Internal voltage drop	D-A93 — 2.4 V or less (to 20 mA)/3 V or less (to 40 mA) D-A93V — 2.7 V or less		0.8 V or less
Indicator light	Red LED lights when ON		

● Lead wire

D-A90(V), D-A93(V) — Oil proof heavy duty vinyl cable, $\phi 2.7$, 0.18 mm² x 2 cores (brown, blue), 0.5 m
 D-A96(V) — Oil proof heavy duty vinyl cable, $\phi 2.7$, 0.15 mm² x 3 cores (brown, black, blue), 0.5 m

Note 1) Refer to page 25 for reed switch common specifications.

Note 2) Refer to page 25 lead wire length.

Weight

Unit: g

Model	D-A90	D-A90V	D-A93	D-A93V	D-A96	D-A96V
Lead wire length 0.5 m	6	6	6	6	8	8
Lead wire length 3 m	30	30	30	30	41	41

Dimensions

D-A90, D-A93, D-A96

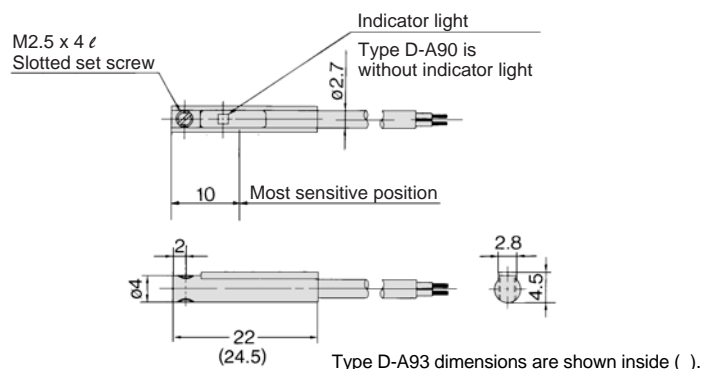

D-A90V, D-A93V, D-A96V

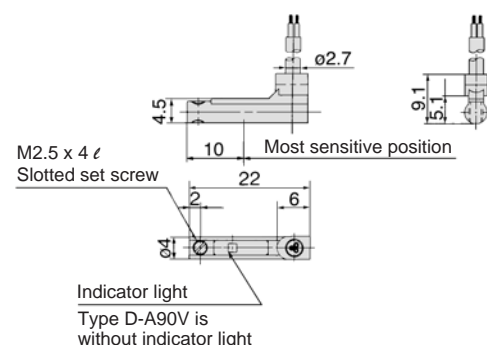

Solid State Switches/Direct Mounting Type D-M9N, D-M9P, D-M9B



For details about certified products conforming to international standards, visit us at www.smcworld.com.

Auto Switch Specifications

PLC: Programmable Logic Controller

D-M9□ (with indicator light)			
Switch model	D-M9N	D-M9P	D-M9B
Wiring type	3-wire		2-wire
Output type	NPN	PNP	—
Applicable load	IC circuit, Relay, PLC		24 VDC relay, PLC
Power supply voltage	5, 12, 24 VDC (4.5 to 28 V)		—
Current consumption	10 mA or less		—
Load voltage	28 VDC or less	—	24 VDC (10 to 28 VDC)
Load current	40 mA or less		2.5 to 40 mA
Internal voltage drop	0.8 V or less		4 V or less
Leakage current	100 μA or less at 24 VDC		0.8 mA or less
Indicator light	Red LED lights when ON		

- Lead wire Oil proof heavy duty vinyl cable: 2.7 x 3.2 ellipse
 D-M9B 0.15 mm² x 2 cores
 D-M9N, D-M9P 0.15 mm² x 3 cores

Note 1) Refer to page 25 for solid state auto switch common specifications.
 Note 2) Refer to page 25 for lead wire length.

Grommet

- 2-wire load current is reduced (2.5 to 40 mA).
- Lead-free
- Use of lead wire compliant with UL standards (style 2844)



Caution

Operating Precautions

When the cable sheath is stripped, confirm the stripping direction. The insulator may be split or damaged depending on the direction.

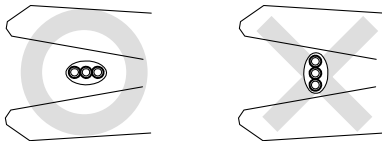

Auto Switch Internal Circuit

D-M9N

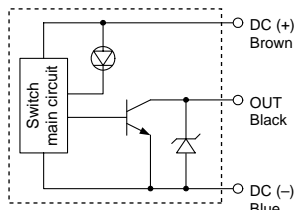

D-M9P

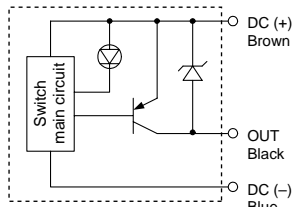

D-M9B

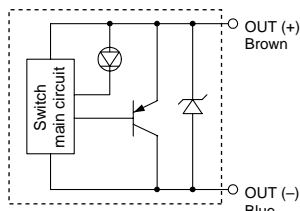

Weight

Unit: g

Auto switch model	D-M9N	D-M9P	D-M9B
Lead wire length (m)	0.5	8	7
	3	41	38
	5	68	63

Dimensions

D-M9□ D-M9B, N, P

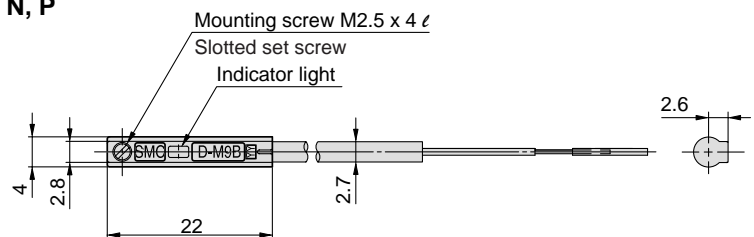

D-M9N, P (3-wire)

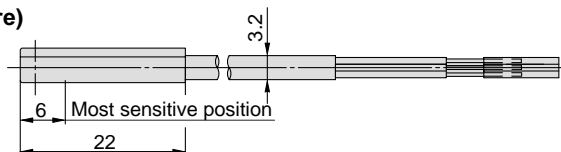

D-M9B (2-wire)

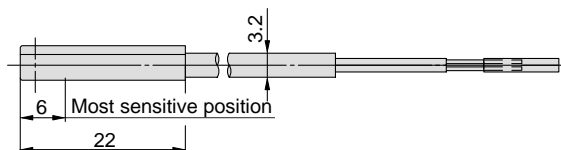

Solid State Switches: Direct Mounting Type D-M9NV, D-M9PV, D-M9BV



Refer to www.smcworld.com for details of products compatible with overseas standards.

Auto Switch Specifications

PLC: Programmable Logic Controller

D-M9□ (with indicator light)			
Switch model	D-M9N	D-M9P	D-M9B
Wiring type	3-wire		2-wire
Output type	NPN	PNP	—
Applicable load	IC circuit, Relay, PLC		24 VDC relay, PLC
Power supply voltage	5, 12, 24 VDC (4.5 to 28 V)		—
Current consumption	10 mA or less		—
Load voltage	28 VDC or less	—	24 VDC (10 to 28 VDC)
Load current	40 mA or less		2.5 to 40 mA
Internal voltage drop	0.8 V or less		4 V or less
Leakage current	100 μA or less at 24 VDC		0.8 mA or less
Indicator light	Red LED lights when ON		

- Lead wire Oil proof heavy duty vinyl cord: 2.7 × 3.2 ellipse
 D-M9B 0.15 mm² × 2 cores
 D-M9N, D-M9P 0.15 mm² × 3 cores

Note 1) Refer to page 15 for solid state auto switch common specifications and lead wire length.

Weight

Unit: g

Auto switch model	D-M9N(V)	D-M9P(V)	D-M9B(V)
Lead wire length m	0.5	8	7
	3	41	38

Dimensions

D-M9□V

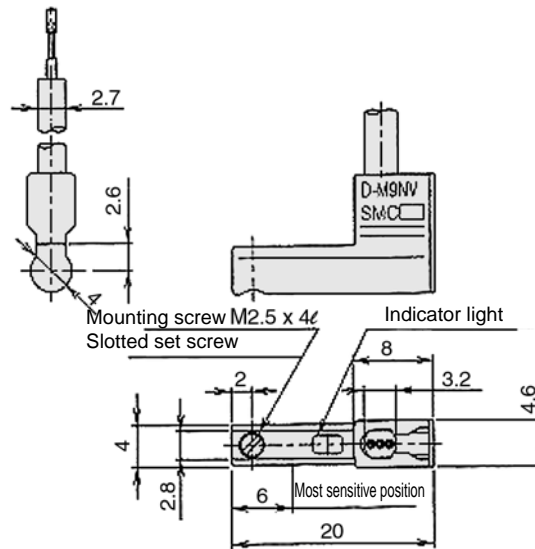

Grommet

- 2-wire load current is reduced (2.5 to 40 mA).
- Lead-free
- Use of lead wire compliant with UL standards (style 2844)
- 1.5 times the flexibility compared with conventional products (comparison with other SMC products)

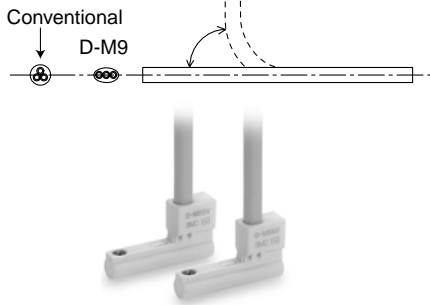

Caution

Operating Precautions

When the cable sheath is stripped, confirm the stripping direction. The insulator may be split or damaged depending on the direction.

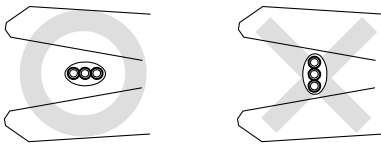

Auto Switch Internal Circuit

D-M9N, D-M9NV

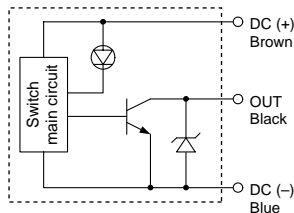

D-M9P, D-M9PV

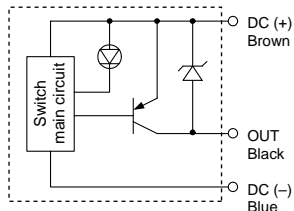

D-M9B, D-M9BV

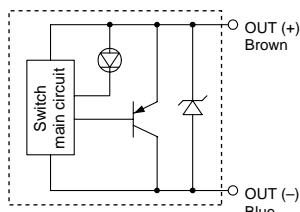

2-color Display Solid State Switches/ Direct Mounting Type

D-M9NW(V), D-M9PW(V), D-M9BW(V)



For details about certified products conforming to international standards, visit us at www.smcworld.com.

Auto Switch Specifications

PLC: Programmable Logic Controller

D-M9□W, D-M9□WV (with indicator light)						
Auto switch part no.	D-M9NW	D-M9NWV	D-M9PW	D-M9PWV	D-M9BW	D-M9BWV
Electrical entry direction	In-line	Perpendicular	In-line	Perpendicular	In-line	Perpendicular
Wiring type	3-wire				2-wire	
Output type	NPN		PNP		—	
Applicable load	IC circuit, Relay, PLC				24 VDC relay, PLC	
Power supply voltage	5, 12, 24 VDC (4.5 to 28 V)				—	
Current consumption	10 mA or less				—	
Load voltage	28 VDC or less		—		24 VDC (10 to 28 VDC)	
Load current	40 mA or less		80 mA or less		5 to 40 mA	
Internal voltage drop	1.5 V or less (0.8 V or less at 10 mA load current)		0.8 V or less		4 V or less	
Leakage voltage	100 μA or less at 24 VDC				0.8 mA or less	
Indicator light	Actuated position Red LED light up Optimum operating position Green LED light up					

Grommet



Auto Switch Internal Circuits

D-M9NW, M9NWV

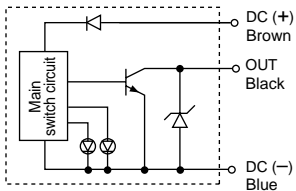

D-M9PW, M9PWV

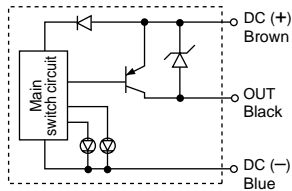

D-M9BW, M9BWV

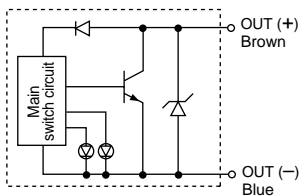

Indicator light/Display method

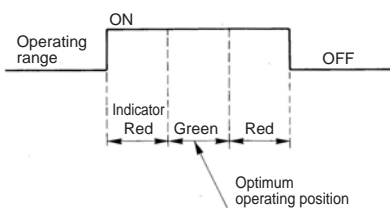

●Lead wire — Oil proof heavy duty vinyl cable, $\phi 2.7$, 0.15 mm² x 3 cores (brown, black, blue), 0.18 mm² x 2 cores (brown, blue), 0.5 m

Note 1) Refer to page 25 for solid state switch common specifications.

Note 2) Refer to page 25 for lead wire length.

Weight

Unit: g

Auto switch model	D-M9NW(V)	D-M9PW(V)	D-M9BW(V)
Lead wire length (m)	0.5	7	7
	3	34	32
	5	56	52

Dimensions

D-M9□W

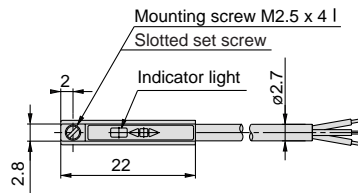
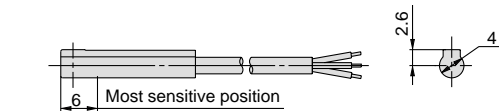

D-M9□WV

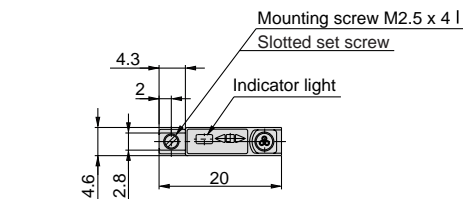
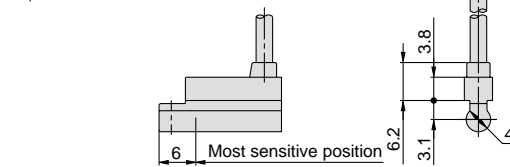

Solid State Switches/Direct Mounting Type D-F8N, D-F8P, D-F8B

 For details about certified products conforming to international standards, visit us at www.smcworld.com.

Auto Switch Specifications

PLC: Programmable Logic Controller

Auto switch part no.	D-F8N	D-F8P	D-F8B
Electrical entry direction	Perpendicular	Perpendicular	Perpendicular
Wiring type	3-wire		2-wire
Output type	NPN	PNP	—
Applicable load	IC circuit, 24 VDC relay, PLC		24 VDC relay, PLC
Power supply voltage	5, 12, 24 VDC (4.5 to 28 V)		—
Current consumption	10 mA or less		—
Load voltage	28 VDC or less	—	24 VDC (10 to 28 V)
Load current	40 mA or less	80 mA or less	2.5 to 40 mA
Internal voltage drop	1.5 V or less (0.8 V or less at 10 mA load current)	0.8 V or less	4 V or less
Leakage current	100 μ A or less at 24 VDC		0.8 mA or less at 24 VDC
Indicator light	Red LED light when ON		

- Lead wire — Heavy duty oil resistant vinyl cable, ϕ 2.7, 0.5 m
 - D-F8N, D-F8P 0.15 mm² x 3 wire (Brown, Black, Blue)
 - D-F8B 0.18 mm² x 2 wire (Brown, Blue)

Note 1) Refer to page 25 for solid state switch common specifications.

Note 2) Refer to page 25 for lead wire length.

Grommet



Caution

Precautions

When securing the switch, be sure to use the fixing screws attached to the auto switch body. The switch may be damaged if screws other than specified ones are used.

Auto Switch Internal Circuits

D-F8N

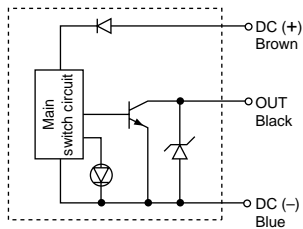

D-F8P

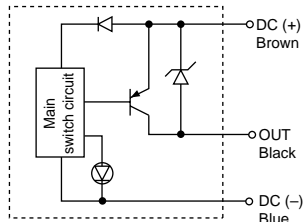

D-F8B

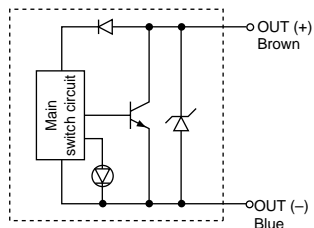

Weight

Unit: g

Auto switch model	D-F8N	D-F8P	D-F8B
Lead wire length (m)	0.5	7	7
	3	32	32
	5	52	52

Dimensions

D-F8N, D-F8P, D-F8B

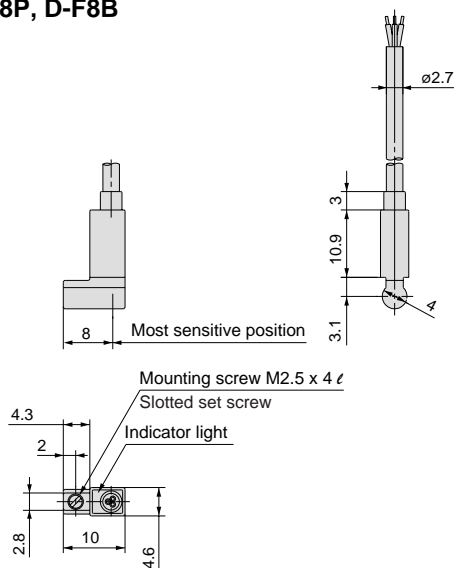



Series MSQ

Safety Instructions

These safety instructions are intended to prevent a hazardous situation and/or equipment damage. These instructions indicate the level of potential hazard by labels of "**Caution**", "**Warning**" or "**Danger**". To ensure safety, be sure to observe ISO 4414 ^{Note 1)}, JIS B 8370 ^{Note 2)} and other safety practices.

⚠ Caution : Operator error could result in injury or equipment damage.

⚠ Warning: Operator error could result in serious injury or loss of life.

⚠ Danger : In extreme conditions, there is a possible result of serious injury or loss of life.

Note 1) ISO 4414 : Pneumatic fluid power – General rules relating to systems

Note 2) JIS B 8370 : Pneumatic system axion

⚠ Warning

1. The compatibility of pneumatic equipment is the responsibility of the person who designs the pneumatic system or decides its specifications.

Since the products specified here are used in various operating conditions, their compatibility with the specific system must be based on specifications or after analysis and/or tests to meet your specific requirements. The expected performance and safety assurance will be the responsibility of the person who has determined the compatibility of the system. This person should continuously review the suitability of all items specified, referring to the latest catalogue information with a view to giving due consideration to any possibility of equipment failure when configuring a system.

2. Only trained personnel should operate pneumatically operated machinery and equipment.

Compressed air can be dangerous if handled incorrectly. Assembly, handling or maintenance of pneumatic systems should be performed by trained and experienced operators.

3. Do not service machinery/equipment or attempt to remove components until safety is confirmed.

1. Inspection and maintenance of machinery/equipment should only be performed once measures to prevent falling or runaway of the driven object have been confirmed.
2. When equipment is to be removed, confirm the safety process as mentioned above. Cut the supply pressure for this equipment and exhaust all residual compressed air in the system.
3. Before machinery/equipment is restarted, take measures to prevent shooting-out of cylinder piston rod, etc.

4. Contact SMC if the product is to be used in any of the following conditions:

1. Conditions and environments beyond the given specifications, or if product is used outdoors.
2. Installation on equipment in conjunction with atomic energy, railway, air navigation, vehicles, medical equipment, food and beverages, recreation equipment, emergency stop circuits, clutch and brake circuits in press applications, or safety equipment.
3. An application which has the possibility of having negative effects on people, property, or animals, and therefore requires special safety analysis.



Design

Warning

1. **If the case involves load fluctuations, lifting or lowering operations or changes in frictional resistance, employ a safety design which allows for these factors.**

Increases in operating speed can cause human injury as well as damage to equipment and machinery.

2. **Install a protective cover when there is a risk of human injury.**

If a driven object and moving parts of a cylinder pose a danger of human injury, design the structure to avoid contact with the human body.

3. **Securely tighten all stationary parts and connected parts so that they will not become loose.**

Especially when a cylinder operates with high frequency or is installed where there is a lot of vibration, ensure that all parts remain secure.

4. **A deceleration circuit or shock absorber, etc., may be required.**

When a driven object is operated at high speed or the load is heavy, a cylinder's cushion will not be sufficient to absorb the impact. Install a deceleration circuit to reduce the speed before cushioning, or install an external shock absorber to relieve the impact. In this case, the rigidity of the machinery should also be examined.

5. **Consider a possible drop in operating pressure due to a power outage, etc.**

When a cylinder is used in a clamping mechanism, there is a danger of work piece dropping if there is a decrease in clamping force due to a drop in circuit pressure caused by a power outage, etc. Therefore, safety equipment should be installed to prevent damage to machinery and/or human injury.

6. **Consider a possible loss of power source.**

Measures should be taken to protect against human injury and equipment damage in the event that there is a loss of power to equipment controlled by air pressure, electricity or hydraulics, etc.

7. **When a speed controller is mounted as an exhaust throttle, employ a safety design which considers residual pressure.**

If the air supply side is pressurized when there is no residual pressure on the exhaust side, operation will be abnormally fast and this can cause human injury as well as damage to equipment and machinery.

8. **Consider emergency stops.**

Design so that human injury and/or damage to machinery and equipment will not be caused by operation of a rotary actuator when machinery is stopped by a safety device under abnormal conditions, a power outage or a manual emergency stop.

9. **Consider the action when operation is restarted after an emergency stop or abnormal stop.**

Design the machinery so that human injury or equipment damage will not occur upon restart of operation. When the rotary actuator has to be reset at the starting position, install safe manual control equipment.

10. **Do not use the product as a shock absorbing mechanism.**

If abnormal pressure or air leakage occurs, there may be a drastic loss of deceleration effectiveness, leading to a danger of human injury as well as damage to equipment and machinery.

Selection

Warning

1. **Keep the speed setting within the product's allowable energy value.**

Operation with the kinetic energy of the load exceeding the allowable value can cause damage to the product, leading to human injury as well as damage to equipment and machinery.

2. **Provide a shock absorbing mechanism when kinetic energy applied to the product exceeds the allowable value.**

Operation exceeding the allowable kinetic energy can cause damage to the product and lead to human injury and damage to equipment and machinery.

3. **Do not perform stops or holding operations by containing air pressure inside the product.**

If intermediate stops are performed by containing air with a directional control valve when the product does not have an external stopping mechanism, the stopping position may not be held due to leakage, etc. This can cause human injury and damage to equipment and machinery.

Caution

1. **Do not operate the product at low speeds which are below the prescribed speed adjustment range.**

If operated at low speeds below the speed adjustment range, this may cause sticking and slipping or stopping of operation.

2. **Do not apply external torque exceeds the product's rated output.**

If external force is applied which exceeds the product's rated output, the product can be damaged.

3. **Rotation end holding torque for double piston type.**

With a double piston type product, if the internal piston is stopped by contact with the angle adjustment screw or cover, the holding torque at the rotation end is half the effective output.

4. **When repeatability of the rotation angle is required, the load should be directly stopped externally.**

The initial rotation angle may vary even in products equipped with angle adjustment.

5. **Avoid operation with oil hydraulics**

Operation with oil hydraulics can cause damage to the product.



Series MSQ

Rotary Table Precautions 2

Be sure to read before handling.

Mounting

⚠ Warning

1. When angle adjustment is performed while applying pressure, make advance preparations to keep equipment from rotating any more than necessary.

When adjustment is performed with pressure applied, there is a possibility of rotation and dropping during adjustment depending on the mounting position of the equipment, etc. This can cause human injury and damage to equipment and machinery.

2. Do not loosen the angle adjustment screw above the adjustment range.

If the angle adjustment screw is loosened above the adjustment range, it may come out causing human injury and damage to equipment and machinery.

3. Do not allow external magnetism close to the product.

Since the auto switches used are types sensitive to magnetism, external magnetism in close proximity to the product can cause malfunction leading to human injury and damage to equipment and machinery.

4. Do not perform additional machining to the product.

Additional machining of the product can result in insufficient strength and cause damage to the product leading to human injury and damage to equipment and machinery.

5. Do not enlarge the fixed throttle on the piping port by reworking, etc.

If the bore is enlarged, rotation speed and impact force will increase, which can cause damage to the product leading to human injury and damage to equipment and machinery.

6. When using a shaft coupling, use one with a sufficient degree of freedom.

If a shaft coupling is used which does not have a sufficient degree of freedom, twisting will occur due to eccentricity, and this can cause malfunction and product damage leading to human injury and damage to equipment and machinery.

7. Do not apply loads to the rotary table exceeding the values shown on page 2.

If loads exceeding the allowable values are applied to the product, this can cause malfunction and product damage leading to human injury and damage to equipment and machinery.

Precautions when using external stoppers

When the kinetic energy generated by the load exceeds the limit value of the actuator, an external shock absorbing mechanism must be provided to absorb the energy. The correct method for mounting external stopper is explained in the figure below.

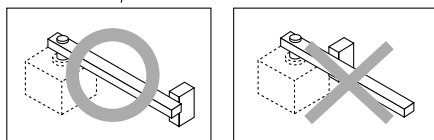
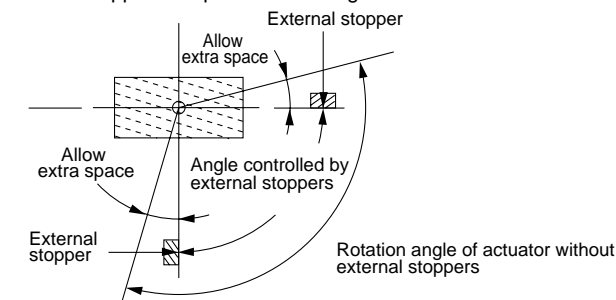

External stopper becomes a fulcrum, and load's inertial force is applied to shaft as bending moment.

⚠ Caution

1. Do not secure the body and strike the rotary table or secure the rotary table and strike the body, etc.

This can bend the rotary table and cause damage to the bearing. When installing a load, etc., on the rotary table, secure the rotary table.

2. Do not step directly on the rotary table or the equipment installed on the rotary table.

Stepping directly on the rotary table can cause damage to the rotary table and bearing, etc.

3. Operate products equipped with the angle adjustment function within the prescribed adjustment range.

Operation outside the adjustment range can cause malfunction and product damage. Refer to product specifications for the adjustment range of each product.

4. When connecting pipes, thoroughly clean the pipes and fittings by blowing with clean air.

5. When screwing together pipes and fittings, etc., be certain that chips from the pipe threads and sealing material do not get inside the piping.

Also, when a pipe tape is used, leave 1.5 to 2 thread ridges exposed at the end of the threads.

Air Supply

⚠ Warning

1. Use clean air.

Do not use compressed air which includes chemicals, synthetic oils containing organic solvents, salt or corrosive gases, etc., as it can cause damage or malfunction.

⚠ Caution

1. Install air filters.

Install air filters at the upstream side of valves. The rated filtration should be 5 μm or finer.

2. Install an after cooler, air dryer or water separator (Drain catch), etc.

Air that includes excessive drainage may cause malfunction of rotary actuators and other pneumatic equipment. To prevent this, install an after cooler air dryer or water separator, etc.

3. Use the product within the specified range of fluid and ambient temperature.

Take measures to prevent freezing, since moisture in circuits may be frozen under 5°C, and this can cause damage to seals and lead to malfunction.

Refer to SMC's "Best Pneumatic vol.4" catalogue for further details on compressed air quality.



Series MSQ

Rotary Table Precautions 3

Be sure to read before handling.

Operating Environment

⚠ Warning

1. Do not use in environments where there is a danger of corrosion.
Refer to the construction drawings regarding rotary actuator materials.
2. Do not use in dusty locations or where water and oil, etc., splash on the equipment.

Speed Adjustment

⚠ Warning

1. Perform speed adjustment gradually from the low speed side.
Speed adjustment from the high speed side can cause product damage leading to human injury and damage to equipment and machinery.

⚠ Caution

1. When operating at high speed with a large load weight, a large amount of energy is applied to the actuator and can cause damage.
Refer to the model selection on page 1 to find the proper operating time.
2. Do not machine the fixed orifice of the port to enlarge its size. If the fixed orifice size is enlarged, the actuator operating speed and impact force will increase and cause damage.

Lubrication

⚠ Caution

1. Use the product without lubrication.
This product is lubricated with grease at the factory, and further lubrication will result in a failure to meet the product's specifications.

Maintenance

⚠ Warning

1. Maintenance should be performed according to the procedure indicated in the instruction manual. Improper handling can cause damage and malfunction of equipment and machinery.
2. During maintenance, do not disassemble while the electric power and supply air are turned ON.
3. Conduct suitable function tests after the product has been disassembled for maintenance.
Failure to test functions can result in inability to satisfy the product specifications.

Maintenance

⚠ Caution

1. For lubrication use the grease specified for each product.
Use of a lubricant other than that specified can cause damage to seals, etc.

Rotation Adjustment

⚠ Caution

1. As a standard feature, the rotary table is equipped with a rotation adjustment screw (adjustment bolt or shock absorber) that can be used to adjust the rotation. The table below shows the rotation adjustment per single rotation of the rotation adjustment screw. Please refer to following pages for the rotation direction, rotation angle and rotation angle range.
MSQ size 1 to 7 → page 9
MSQ size 10 to 200 → page 14
MSQ with external shock absorber → page 21

With adjustment bolt, With external shock absorber

Size	Rotation adjustment per single rotation of rotation adjustment screw
1	8.2°
2	10.0°
3	10.9°
7	10.2°
10	10.2°
20	7.2°
30	6.5°
50	8.2°
70	7.0°
100	6.1°
200	4.9°

With external shock absorber

Size	Rotation adjustment per single rotation of rotation adjustment screw
10	1.4°
20	1.2°
30	1.1°
50	1.3°

The rotation adjustment range for the external shock absorber is $\pm 3^\circ$ at each rotation end. When adjusted beyond this range, note that the shock absorber's durability may decrease.

2. Series MSQ is equipped with a rubber bumper or shock absorber. Therefore, perform rotation adjustment in the pressurized condition (minimum operation pressure: 0.1 MPa or more for adjustment bolt and internal shock absorber types, and 0.2 MPa or more for external shock absorber type.)



Series MSQ

Rotary Table Precautions 4

Be sure to read before handling.

Shock Absorber

⚠ Caution

1. Refer to the table below for tightening torques of the shock absorber setting nut.

Size	10	20	30	50	70	100	200
Tightening torque N · m	1.67	3.14		10.8		23.5	62.8

2. Never rotate the bottom screw of the shock absorber. (It is not an adjustment screw.) This may cause oil leakage.

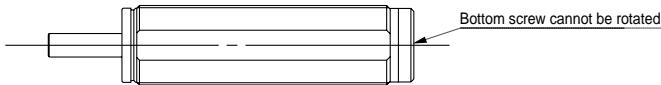

3. When rotation of the rotary table with internal shock absorber is set at a value smaller than the table below, the piston stroke becomes smaller than the shock absorber's effective stroke and energy absorption capacity decreases.

Size	10	20	30	50	70	100	200
Minimum rotation without energy absorption capacity decrease	52°	43°	40°	60°	71°	62°	82°

4. Products with shock absorber are not designed to smooth stop but to absorb the kinetic energy of the load. If the load has to be stopped smoothly, a shock absorber of the optimum size meeting the operating conditions must be installed external to the equipment.
5. Shock absorbers are consumable parts. When a decrease in energy absorption capacity is noticed, it must be replaced.

With internal shock absorber

Size	Shock absorber model
10	RBA0805-X692
20	RBA1006-X692
30	
50	RBA1411-X692
70	RBA2015-X821
100	
200	RBA2725-X821

With external shock absorber

Size	Type	Shock absorber model
10	For low energy	RB0805
	For high energy	RB0806
20	For low energy	RB1006
	For high energy	RB1007
30	For low energy	RB1006
	For high energy	RB1007
50	For low energy	RB1411
	For high energy	RB1412

External Shock Absorber

⚠ Caution

The threaded orifices shown below are not connecting ports. Never remove the plugs as this will cause malfunction.

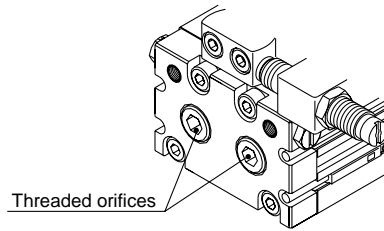

Speed Controller and Fittings

⚠ Caution

Size 1, 2, and 3 use M3 x 0.5 piping ports. When connecting a speed controller or fittings directly, use the following series.

- Speed controller
 - AS12□1F/Elbow type
 - AS13□1F/Universal type
- One-touch fitting
 - One-touch miniature fittings Series K J
- Miniature fittings Series M3

Auto switch

⚠ Caution

In case of sizes 1, 2, 3 and 7, when 2 pieces of auto switches are installed in one switch groove, the minimum detectable rotation angles are as follows.

Size	Minimum detectable rotation
1	25°
2	25°
3	20°
7	20°

Maintenance and Inspection

⚠ Caution

Because sizes 1, 2, 3 and 7 require special tools, they cannot be disassembled.

Because sizes 10, 20, 30 and 50 have the table press fit into an angular type bearing, they cannot be disassembled.



Series MSQ

Auto Switch Precautions 1

Be sure to read before handling.

Design and Selection

Warning

1. Confirm the specifications.

Read the specifications carefully and use this product appropriately. The product may be damaged or malfunction if it is used outside the range of specifications for current load, voltage, temperature or impact.

2. Take precautions when multiple cylinders are used close together.

When multiple auto switch cylinders are used in close proximity, magnetic field interference may cause the switches to malfunction. Maintain a minimum cylinder separation of 40 mm. (When the allowable separation is indicated for each cylinder series, use the specified value.)

3. Pay attention to the length of time that a switch is ON at an intermediate stroke position.

When an auto switch is placed at an intermediate position of the stroke and a load is driven at the time the piston passes, the auto switch will operate, but if the speed is too great the operating time will be shortened and the load may not operate properly. The maximum detectable piston speed is:

$$V \text{ (mm/s)} = \frac{\text{Auto switch operating range (mm)}}{\text{Load operating time (ms)}} \times 1000$$

4. Keep wiring as short as possible.

<Reed switch>

As the length of the wiring to a load gets longer, the rush current at switching ON becomes greater, and this may shorten the product's life. (The switch will stay ON all the time.)

1) For an auto switch without a contact protection circuit, use a contact protection box when the wire length is 5 m or longer.

<Solid state switch>

2) Although wire length does not affect switch function, use wiring 100 m or shorter.

5. Take precautions for the internal voltage drop of the switch.

<Reed switch>

1) Switches with an indicator light (Except D-A96, A96V)

• If auto switches are connected in series as shown below, take note that there will be a large voltage drop because of internal resistance in the light emitting diodes. (Refer to internal voltage drop in the auto switch specifications.)

[The voltage drop will be "n" times larger when "n" auto switches are connected.]

Even though an auto switch operates normally, the load may not operate.

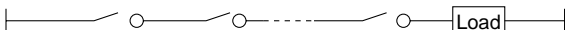

• In the same way, when operating under a specified voltage, although an auto switch may operate normally, the load may not operate. Therefore, the formula below should be satisfied after confirming the minimum operating voltage of the load.

$$\text{Supply voltage} - \text{Internal voltage drop of switch} > \text{Minimum operating voltage of load}$$

2) If the internal resistance of a light emitting diode causes a problem, select a switch without an indicator light (Model A90, A90V).

<Solid state switch>

3) Generally, the internal voltage drop will be greater with a 2-wire solid state auto switch than with a reed switch. Take the same precautions as in 1).

Also, note that a 12 VDC relay is not applicable.

6. Pay attention to leakage current.

<Solid state switch>

With a 2-wire solid state auto switch, current (leakage current) flows to the load to operate the internal circuit even when in the OFF state.

$$\text{Operating current of load (Input OFF current in case of a controller)} > \text{Leakage current}$$

If the criteria given by the above formula are not met, it will not reset correctly (stays ON). Use a 3-wire switch if this specification will not be satisfied.

Moreover, leakage current flow to the load will be "n" times larger when "n" auto switches are connected in parallel.

7. Do not use a load that generates surge voltage.

<Reed switch>

If driving a load such as a relay that generates a surge voltage, use a switch with a built-in contact protection circuit or use a contact protection box.

<Solid state switch>

Although a zener diode for surge protection is connected at the output side of a solid state auto switch, damage may still occur if the surge is applied repeatedly. When a load, such as a relay or solenoid valve, which generates surge is directly driven, use a type of switch with a built-in surge absorbing element.

8. Cautions for use in an interlock circuit

When an auto switch is used for an interlock signal requiring high reliability, devise a double interlock system to avoid trouble by providing a mechanical protection function, or by also using another switch (sensor) together with the auto switch. Also perform periodic maintenance and confirm proper operation.

9. Ensure sufficient clearance for maintenance activities.

When designing an application, be sure to allow sufficient clearance for maintenance and inspections.



Series MSQ

Auto Switch Precautions 2

Be sure to read before handling.

Mounting and Adjustment

⚠ Warning

1. Do not drop or bump.

Do not drop, bump or apply excessive impacts (300 m/s² or more for reed switches and 1000 m/s² or more for solid state switches) while handling.

Although the body of the switch may not be damaged, the inside of the switch could be damaged and cause a malfunction.

2. Do not carry a cylinder by the auto switch lead wires.

Never carry a cylinder by its lead wires. This may not only cause broken lead wires, but it may cause internal elements of the switch to be damaged by the stress.

3. Mount switches using the proper tightening torque.

When a switch is tightened beyond the range of tightening torque, the mounting screws mounting bracket or switch may be damaged. On the other hand, tightening below the range of tightening torque may allow the switch to slip out of position.

4. Mount a switch at the center of the operating range.

Adjust the mounting position of an auto switch so that the piston stops at the center of the operating range (the range in which a switch is ON). (The mounting positions shown in the catalog indicate the optimum positions at stroke end.) If mounted at the end of the operating range (around the borderline of ON and OFF), operation may be unstable.

Wiring

⚠ Warning

1. Avoid repeatedly bending or stretching lead wires.

Broken lead wires will result from repeatedly applying bending stress or stretching force to the lead wires.

2. Be sure to connect the load before power is applied.

<2-wire type>

If the power is turned ON when an auto switch is not connected to a load, the switch will be instantly damaged because of excess current.

3. Confirm proper insulation of wiring.

Be certain that there is no faulty wiring insulation (contact with other circuits, ground fault, improper insulation between terminals, etc.). Damage may occur due to excess current flow into a switch.

4. Do not wire with power lines or high voltage lines.

Wire separately from power lines or high voltage lines, avoiding parallel wiring or wiring in the same conduit with these lines. Control circuits containing auto switches may malfunction due to noise from these other lines.

Wiring

⚠ Warning

5. Do not allow short circuit of loads.

<Reed switch>

If the power is turned ON with a load in a short circuit condition, the switch will be instantly damaged because of excess current flow into the switch.

<Solid state switch>

Model D-M9□(V), M9□W(V), D-M9□ and all models of PNP output type switches do not have built-in short circuit protection circuits. If loads are short circuited, the switches will be instantly damaged, as in the case of reed switches.

Take special care to avoid reverse wiring with the brown [red] power supply line and the black [white] output line on 3-wire type switches.

6. Avoid incorrect wiring.

<Reed switch>

A 24 VDC switch with indicator light has polarity. The brown [red] lead wire is (+), and the blue [black] lead wire is (-).

1) If connections are reversed, a switch will operate, however, the light emitting diode will not light up.

Also note that a current greater than that specified will damage a light emitting diode and it will no longer operate.

Applicable models: D-A93, A93V

<Solid state switch>

1) If connections are reversed on a 2-wire type switch, the switch will not be damaged if protected by a protection circuit, but the switch will be in a normally ON state.

However, note that the switch will be damaged if reversed connections are made while the load is in a short circuited condition.

2) If connections are reversed (power supply line + and power supply line -) on a 3-wire type switch, the switch will be protected by a protection circuit. However, if the power supply line (+) is connected to the blue [black] wire and the power supply line (-) is connected to the black [white] wire, the switch will be damaged.

* Lead wire colour changes

Lead wire colours of SMC switches have been changed in order to meet NECA Standard 0402 for production beginning September, 1996 and thereafter. Please refer to the tables provided.

Special care should be taken regarding wire polarity during the time that the old colors still coexist with the new colours.

2-wire

	Old	New
Output (+)	Red	Brown
Output (-)	Black	Blue

3-wire

	Old	New
Power supply	Red	Brown
GND	Black	Blue
Output	White	Black

Solid state with diagnostic output

	Old	New
Power supply	Red	Brown
GND	Black	Blue
Output	White	Black
Diagnostic output	Yellow	Orange

Solid state with latch type diagnostic output

	Old	New
Power supply	Red	Brown
GND	Black	Blue
Output	White	Black
Latch type diagnostic output	Yellow	Orange



Series MSQ

Auto Switch Precautions 3

Be sure to read before handling.

Operating Environment

Warning

1. Never use in an atmosphere of explosive gases.

The structure of auto switches is not intended to prevent explosion. Never use in an atmosphere with an explosive gas since this may cause a serious explosion.

2. Do not use in an area where a magnetic field is generated.

Auto switches will malfunction or magnets inside cylinders will become demagnetized. (Consult SMC regarding the availability of a magnetic field resistant auto switch.)

3. Do not use in an environment where the auto switch will be continually exposed to water.

Although switches, except for some models, satisfy IEC standard IP67 construction (JIS C 0920: watertight construction), do not use switches in applications where continually exposed to water splash or spray. Poor insulation or swelling of the potting resin inside switches may cause malfunction.

4. Do not use in an environment with oil or chemicals.

Consult SMC if auto switches will be used in an environment with coolant, cleaning solvent, various oils or chemicals. If auto switches are used under these conditions for even a short time, they may be adversely affected by improper insulation, malfunction due to swelling of the potting resin, or hardening of the lead wires.

5. Do not use in an environment with temperature cycles.

Consult SMC if switches are used where there are temperature cycles other than normal temperature changes, as they may be adversely affected internally.

6. Do not use in environment where there is excessive impact shock.

<Reed switch>

When excessive impact (300 m/s² or more) is applied to a reed switch during operation, the contact will malfunction and generate or cut off a signal momentarily (1 ms or less). Consult SMC regarding the need to use a solid state switch depending upon the environment.

7. Do not use in an area where surges are generated.

<Solid state switch>

When there are units (solenoid type lifter, high frequency induction furnace, motor, etc.) which generate a large amount of surge in the area around cylinders with solid state auto switches, this may cause deterioration or damage to internal circuit elements of the switch. Avoid sources of surge generation and crossed lines.

8. Avoid accumulation of iron debris or close contact with magnetic substances.

When a large amount of ferrous debris such as machining chips or welding spatter is accumulated, or a magnetic substance (something attracted by a magnet) is brought into close proximity with an auto switch cylinder, it may cause auto switches to malfunction due to a loss of the magnetic force inside the cylinder.

Maintenance

Warning

1. Perform the following maintenance periodically in order to prevent possible danger due to unexpected auto switch malfunction.

- 1) Securely tighten switch mounting screws.
If screws become loose or the mounting position is dislocated, retighten them after readjusting the mounting position.
- 2) Confirm that there is no damage to lead wires.
To prevent faulty insulation, replace switches or repair lead wires, etc., if damage is discovered.
- 3) Confirm the lighting of the green light on a 2-colour display type switch.
Confirm that the green LED is on when stopped at the established position. If the red LED is on, the mounting position is not appropriate. Readjust the mounting position until the green LED lights up.

Other

Warning

1. Consult SMC concerning water resistance, elasticity of lead wires and usage at welding sites, etc.

**EUROPEAN SUBSIDIARIES:****Austria**

SMC Pneumatik GmbH (Austria).
Girakstrasse 8, A-2100 Korneuburg
Phone: +43 2262-62280, Fax: +43 2262-62285
E-mail: office@smc.at
http://www.smc.at

**France**

SMC Pneumatik, S.A.
1, Boulevard de Strasbourg, Parc Gustave Eiffel
Bussy Saint Georges F-77607 Marne La Vallée Cedex 3
Phone: +33 (0)1-6476 1000, Fax: +33 (0)1-6476 1010
E-mail: contact@smc-france.fr
http://www.smc-france.fr

**Netherlands**

SMC Pneumatics BV
De Ruyterkade 120, NL-1011 AB Amsterdam
Phone: +31 (0)20-5318888, Fax: +31 (0)20-5318880
E-mail: info@smcpneumatics.nl
http://www.smcneumatics.nl

**Spain**

SMC España, S.A.
Zuazobidea 14, 01015 Vitoria
Phone: +34 945-184 100, Fax: +34 945-184 124
E-mail: post@smc.smces.es
http://www.smces.es

**Belgium**

SMC Pneumatics N.V./S.A.
Nijverheidsstraat 20, B-2160 Wommelgem
Phone: +32 (0)3-355-1464, Fax: +32 (0)3-355-1466
E-mail: post@smcpneumatics.be
http://www.smcneumatics.be

**Germany**

SMC Pneumatik GmbH
Boschring 13-15, D-63329 Egelsbach
Phone: +49 (0)6103-4020, Fax: +49 (0)6103-402139
E-mail: info@smc-pneumatik.de
http://www.smc-pneumatik.de

**Norway**

SMC Pneumatics Norway A/S
Vollsvien 13 C, Granfos Næringspark N-1366 Lysaker
Tel: +47 67 12 90 20, Fax: +47 67 12 90 21
E-mail: post@smc-norge.no
http://www.smc-norge.no

**Sweden**

SMC Pneumatics Sweden AB
Ekhagsvägen 29-31, S-141 71 Huddinge
Phone: +46 (0)8-603 12 00, Fax: +46 (0)8-603 12 90
E-mail: post@smcpneumatics.se
http://www.smc.nu

**Bulgaria**

SMC Industrial Automation Bulgaria EOOD
16 Kliment Ohridski Blvd., fl.13 BG-1517 Sofia
Phone: +359 2 9744492, Fax: +359 2 9744519
E-mail: office@smc.bg
http://www.smc.bg

**Greece**

S. Parianopoulos S.A.
7, Konstantinoupoleos Street, GR-11855 Athens
Phone: +30 (0)1-3426076, Fax: +30 (0)1-3455578
E-mail: parianos@hol.gr
http://www.smceu.com

**Poland**

SMC Industrial Automation Polska Sp.z.o.o.
ul. Konstruktorska 11A, PL-02-673 Warszawa,
Phone: +48 22 548 5085, Fax: +48 22 548 5087
E-mail: office@smc.pl
http://www.smc.pl

**Switzerland**

SMC Pneumatik AG
Dorfstrasse 7, CH-8484 Weisslingen
Phone: +41 (0)52-396-3131, Fax: +41 (0)52-396-3191
E-mail: info@smc.ch
http://www.smc.ch

**Croatia**

SMC Industrijska automatika d.o.o.
Črnomerec 12, 10000 ZAGREB
Phone: +385 1 377 66 74, Fax: +385 1 377 66 74
E-mail: office@smc.hr
http://www.smceu.com

**Hungary**

SMC Hungary Ipari Automatizálási Kft.
Budafoki út 107-113, H-1117 Budapest
Phone: +36 1 371 1343, Fax: +36 1 371 1344
E-mail: office@smc-automation.hu
http://www.smc-automation.hu

**Portugal**

SMC Sucursal Portugal, S.A.
Rua de Engº Ferreira Dias 452, 4100-246 Porto
Phone: +351 22-610-89-22, Fax: +351 22-610-89-36
E-mail: postpt@smc.smces.es
http://www.smces.es

**Turkey**

Entek Pnömatik San. ve Tic. Ltd. Sti.
Perpa Tic. Merkezi Kat: 11 No: 1625, TR-80270 Okmeydanı Istanbul
Phone: +90 (0)212-221-1512, Fax: +90 (0)212-221-1519
E-mail: smc-entek@entek.com.tr
http://www.entek.com.tr

**Czech Republic**

SMC Industrial Automation CZ s.r.o.
Hudcova 78a, CZ-61200 Brno
Phone: +420 5 414 24611, Fax: +420 5 412 18034
E-mail: office@smc.cz
http://www.smc.cz

**Ireland**

SMC Pneumatics (Ireland) Ltd.
2002 Citywest Business Campus, Naas Road, Saggart, Co. Dublin
Phone: +353 (0)1-403 9000, Fax: +353 (0)1-464-0500
E-mail: sales@smcpneumatics.ie
http://www.smcneumatics.ie

**Romania**

SMC Romania srl
Str. Frunzei 29, Sector 2, Bucharest
Phone: +40 213205111, Fax: +40 213261489
E-mail: smccadm@canad.ro
http://www.smcromania.ro

**UK**

SMC Pneumatics (UK) Ltd
Vincent Avenue, Crownhill, Milton Keynes, MK8 0AN
Phone: +44 (0)800 1382930 Fax: +44 (0)1908-555064
E-mail: sales@smcpneumatics.co.uk
http://www.smcneumatics.co.uk

**Denmark**

SMC Pneumatik A/S
Knudsminde 4B, DK-8300 Odder
Phone: +45 70252900, Fax: +45 70252901
E-mail: smc@smc-pneumatik.dk
http://www.smcdk.com

**Italy**

SMC Italia S.p.A
Via Garibaldi 62, I-20061 Carugate, (Milano)
Phone: +39 (0)2-92711, Fax: +39 (0)2-9271365
E-mail: mailbox@smcitalia.it
http://www.smcitalia.it

**Russia**

SMC Pneumatik LLC.
36/40 Sredny pr. St. Petersburg 199004
Phone: +812 118 5445, Fax: +812 118 5449
E-mail: smcfa@peterlink.ru
http://www.smc-pneumatik.ru

**Estonia**

SMC Pneumatics Estonia OÜ
Laki 12-101, 106 21 Tallinn
Phone: +372 (0)6 593540, Fax: +372 (0)6 593541
E-mail: smc@smcpneumatics.ee
http://www.smcneumatics.ee

**Latvia**

SMC Pneumatics Latvia SIA
Smerla 1-705, Rīga LV-1006, Latvia
Phone: +371 (0)777-94-74, Fax: +371 (0)777-94-75
E-mail: info@smclv.lv
http://www.smclv.lv

**Slovakia**

SMC Priemysel'na' Automatizacia, s.r.o.
Námestie Martina Benku 10, SK-81 107 Bratislava
Phone: +421 2 444 56725, Fax: +421 2 444 56028
E-mail: office@smc.sk
http://www.smc.sk

**Finland**

SMC Pneumatics Finland OY
PL72, Tiistinniityntie 4, SF-02031 ESPOO
Phone: +358 (0)9-859 580, Fax: +358 (0)9-8595 8595
E-mail: smcfi@smc.fi
http://www.smc.fi

**Lithuania**

UAB Ottensten Lietuva
Savanoriu pr. 180, LT-2600 Vilnius, Lithuania
Phone/Fax: +370-2651602

**Slovenia**

SMC industrijska Avtomatika d.o.o.
Grajski trg 15, SLO-8360 Zuzemberk
Phone: +386 738 85240 Fax: +386 738 85249
E-mail: office@smc-ind-avtom.si
http://www.smc-ind-avtom.si

**OTHER SUBSIDIARIES WORLDWIDE:**

ARGENTINA, AUSTRALIA, BOLIVIA, BRASIL, CANADA, CHILE,
CHINA, HONG KONG, INDIA, INDONESIA, MALAYSIA, MEXICO,
NEW ZEALAND, PHILIPPINES, SINGAPORE, SOUTH KOREA,
TAIWAN, THAILAND, USA, VENEZUELA

<http://www.smceu.com>
<http://www.smcworld.com>