

CP96S(D), ISO 15552 Cylinder, Double Acting, Single/Double Rod with Air cushion on both ends and Bumper cushion CP96SDB63-250C

Datasheet

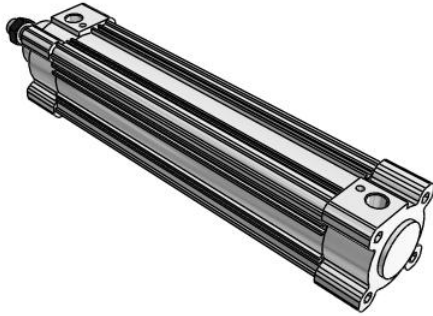

General series information

- Double acting, standard type, single or double rod with Air cushion on both ends and Bumper cushion
- Bore sizes (mm): 32, 40, 50, 63, 80, 100
- Standard stroke up to 2000mm
- Auto switch capable



Double-acting cylinder with cushioning adjustable at both ends, single piston rod

Standard specifications

| | |
|----------------------------------------------------|-------------------------------------------|
| Magnet | D (Built-in) |
| Mounting | B (Basic) |
| Bore Size | Ø63 mm |
| Stroke | 250 |
| Rod Boot | w/o Rod Boot |
| Rod | Single Rod |
| Auto Switch | No Switch |
| Lead Wire or Prewired Connector | 0.5m [Or None in the Case of No Switch] |
| Number | 2 pcs. [Or None in the Case of No Switch] |
| Rod End Options | None |
| Temperature Resistance | None |
| Heavy Duty Scraper | None |
| Tie Rod | None |
| Fluororubber Seal | None |
| Coil Scraper | None |
| Made of Stainless Steel (-XC68) | None |
| Made of Stainless Steel (-XC65) | None |
| Pressure medium | Compressed air |
| Maximum temperature of pressure medium with magnet | 60 °C |

| | |
|---------------------------------------------------------|----------------------|
| Minimum temperature of pressure medium with magnet | -10 °C (no freezing) |
| Maximum operating pressure | 1.0 MPa |
| Minimum operating pressure | 0.05 MPa |
| Proof pressure | 1.5 MPa |
| Maximum ambient temperature with magnet | 60 °C |
| Minimum ambient temperature with magnet | -10 °C (no freezing) |
| Number of pneumatic connections | 2 pcs. |
| Pneumatic input connection | G 3/8 |
| Pneumatic exhaust connection | G 3/8 |
| Mode of operation of drive | Double acting |
| Theoretical cylinder force, advance stroke (at 0.5 MPa) | 1,559 N |
| Theoretical cylinder force, return stroke (at 0.5 MPa) | 1,402 N |
| Maximum piston speed | 1,000 mm/s |
| Piston rod end | Male thread |
| Male thread of rod end | M16 x 1.5 |
| Minimum piston speed | 50 mm/s |
| Weight | 3.080 Kg |

Dimensions

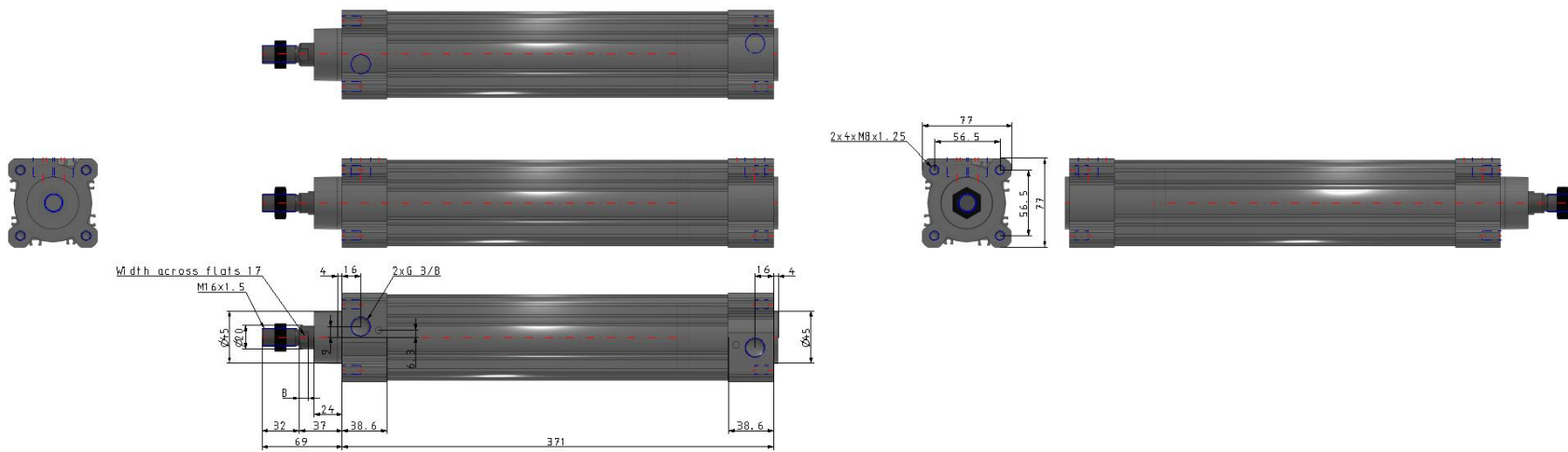

Constructions



Component Parts

| No. | Description | Material | Note |
|-----|----------------------|--------------------|--------------|
| 1 | Rod cover | Aluminium die-cast | |
| 2 | Head cover | Aluminium die-cast | |
| 3 | Cylinder tube | Aluminium alloy | |
| 4 | Piston rod | Carbon steel | |
| 5 | Piston | Aluminium alloy | Ø 32 to Ø 63 |
| | | Aluminium die-cast | Ø 80, Ø 100 |
| 6 | Cushion ring A | Aluminium alloy | |
| 7 | Cushion ring B | Aluminium alloy | |
| 8 | Cushion seal holder | Aluminium alloy | |
| 9 | Tie-rod | Carbon steel | |
| 10 | Tie-rod nut | Steel | |
| 11 | Flat washer | Steel | Ø 80, Ø 100 |
| 12 | Rod end nut | Steel | |
| 13 | Cushion valve | Resin | |
| 14 | Bushing | Bearing alloy | |
| 15 | Cushion seal | Urethane | |
| 16 | Bumper | Urethane | |
| 17 | Wear ring | Resin | |
| 18 | Piston seal | NBR | |
| 19 | Rod seal | NBR | |
| 20 | Cylinder tube gasket | NBR | |
| 21 | Cushion valve seal | NBR | |
| 22 | Magnet | | |

Replacement Parts/Seal Kit (Single rod)

| Bore size [mm] | Kit no. | Contents |
|----------------|----------|-------------------------------------|
| 32 | CS95-32 | Kits include items 15, 17 to 20. |
| 40 | CS95-40 | |
| 50 | CS95-50 | |
| 63 | CS95-63 | |
| 80 | CS95-80 | |
| 100 | CS96-100 | |

Seal Kit (Double rod)

| Bore size [mm] | Kit no. | Contents |
|----------------|-----------|-------------------------------------|
| 32 | CS95W-32 | Kits include items 15, 18 to 20. |
| 40 | CS95W-40 | |
| 50 | CS95W-50 | |
| 63 | CS95W-63 | |
| 80 | CS95W-80 | |
| 100 | CS96W-100 | |

Additional information

Catalogue

[CP96-Bb_EU.pdf](#)

Operation manuals

[OM_CP96-C_OM0002QEN-A.pdf](#)