

CVQ, Compact Cylinder with Solenoid Valve

CVQB32-15-5MO

Datasheet

- Space saving.
- Energy saving.
- Labour saving.
- Improved response speed.
- Different piping directions possible.
- Bore size (mm): 32, 40, 50, 63.
- Stroke (mm): 5~100.

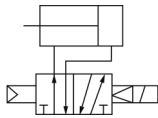

Double acting: single rod compact cylinder with solenoid valve

Standard specifications

Mounting	B (Through Hole)
Bore Size	32mm
Stroke	15mm
Option	Standard (Rod End Female Thread)
Auto Switch	No Switch
Lead Wire or Prewired Connector	0.5m (Or None in the Case of No Switch)
Number	2 pcs. (Or None in the Case of No Switch)
Rated Voltage	5 (24 VDC)
Electrical Entry	MO (M Plug Connector Without Connector)
Surge Voltage Suppressor	W/O Surge Voltage Suppressor
Manual Override	Non-Locking Push Type
Piping	Standard
Port Thread	Rc (32 & 40 Bore: M5; 50 & 63 Bore Rc)
Maximum operating pressure	0.7 MPa
Minimum operating pressure	0.15 MPa
Proof pressure	1.0 MPa
Type of cushioning	Rubber bumper

Actuation type	Double-acting, single-rod
Type of actuation	2 position single
Electrical entry	M-type plug connector
Manual override	Non-looking push type / Locking slotted type
Enclosure	Dustproof
Power Consumption	0.35 (With light: 0.4) W
Fluid	Air (Non-lube)
Rated coil voltage	24/12(VDC)
Allowable voltage range	±10% of the rated voltage
Indicator light	LED
Ambient and fluid temperature	-10 - 50°C
Stroke length tolerance	0 - + 1.0 mm
Rod end thread tolerance	JIS Class 2
Mounting	Through-hole / Both ends tapped
Piston speed	50 - 500 mm/s
Mounting orientation	Unrestricted (based on cylinder mounting orientation)
Pilot exhaust	Main/Pilot valve common exhaust type
Surge voltage suppressor	Diode (Non-polar type: Varistor)
Weight	0.440 Kg

Dimensions

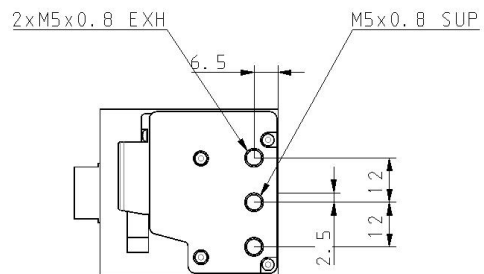
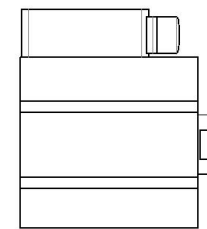
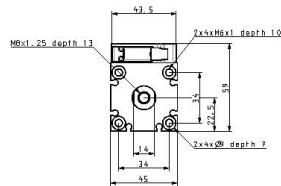
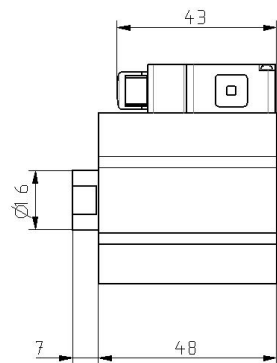
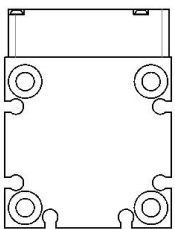
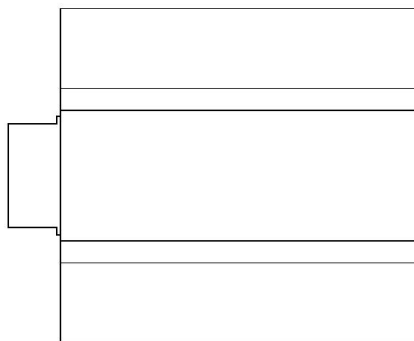

Specifications are subject to change without prior notice and any obligation on the part of the manufacturer.

Constructions

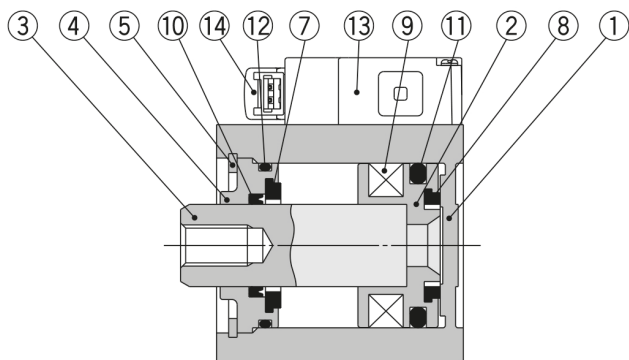

Basic Type

With boss in head end

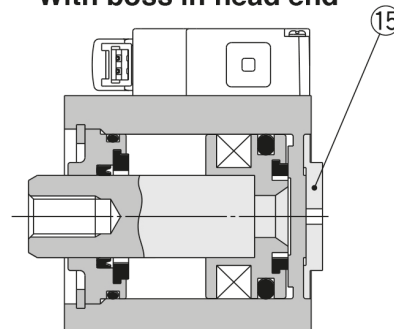

Component Parts

No.	Description	Material	Note
1	Cylinder tube	Aluminum alloy	Hard anodised
2	Piston	Aluminum alloy	Chromated
3	Piston rod	Carbon steel	Hard chrome plated
4	Collar	Aluminum alloy casting	Ø 50, Ø 63, chromate coating
		Aluminum alloy	Anodised
5	Retaining ring	Carbon tool steel	Phosphate coated
6	Bushing	Bearing alloy	Ø 50, Ø 63
7	Bumper A	Urethane	
8	Bumper B	Urethane	
9	Magnet	—	
10	Rod seal	NBR	
11	Piston seal	NBR	
12	Gasket	NBR	
13	Solenoid valve	—	
14	Pilot valve	—	
15	Boss ring	Aluminum alloy	Hard anodised
16	Rod end nut	Carbon steel	Nickel plated

Rod end male thread

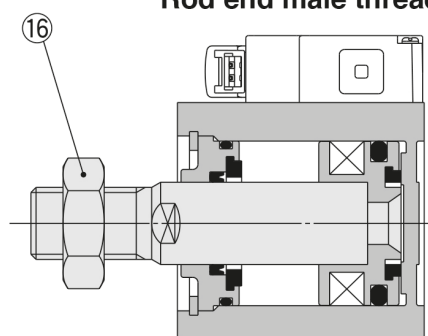

Manual button

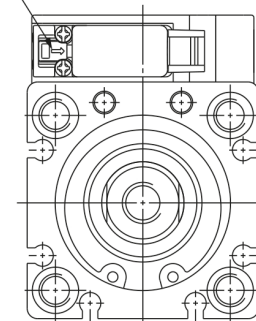

Additional information

Catalogue

[CVQ-B_EU.pdf](#)

Declaration of conformity

[newDoC_CVQx_TF1V309EN.pdf](#)

[newDoC_CVQx_TF1U012EN.pdf](#)