

# CY3R, Magnetically Coupled Rodless Cylinder (with Switch Rail) CY3R32TF-650

Datasheet

## General series information

- Magnetically coupled rodless cylinder
- Direct mount type, with switch rail
- Bore sizes (mm): 6, 10, 15, 20, 25, 32, 40, 50, 63
- Maximum operating pressure: 0.7MPa
- Ambient temperature: -10 to 60°C
- Variety of auto switches available



Magnetically coupled rodless cylinder

## Standard specifications

Piping	Standard
Bore Size	32 mm
Port Thread	TF (G)
Stroke	650
Auto Switch	No Switch
Lead Wire or Prewired Connector	0.5m (Or None in the Case of No Switch)
Number	2 pcs. (Or None in the Case of No Switch)
Maximum operating pressure	0.7 MPa
Minimum operating pressure	0.14 MPa
Proof pressure	1.05 MPa
Type of cushioning	Rubber bumper on both ends
Lubrication	Non-lube
Fluid	Air
Ambient and fluid temperature	-10 - 60 °C
Stroke length tolerance	0 to 250 st: +1.0 , 251 to 1000 st: +1.4, 1001 st to: +1.8
F450 - Mounting	Direct mount type
F452 - Magnetic Holding Force	588 N

Piston speed	50 - 500 mm/s
F454 - Mounting orientation	Horizontal, Inclined, Vertical

# Dimensions

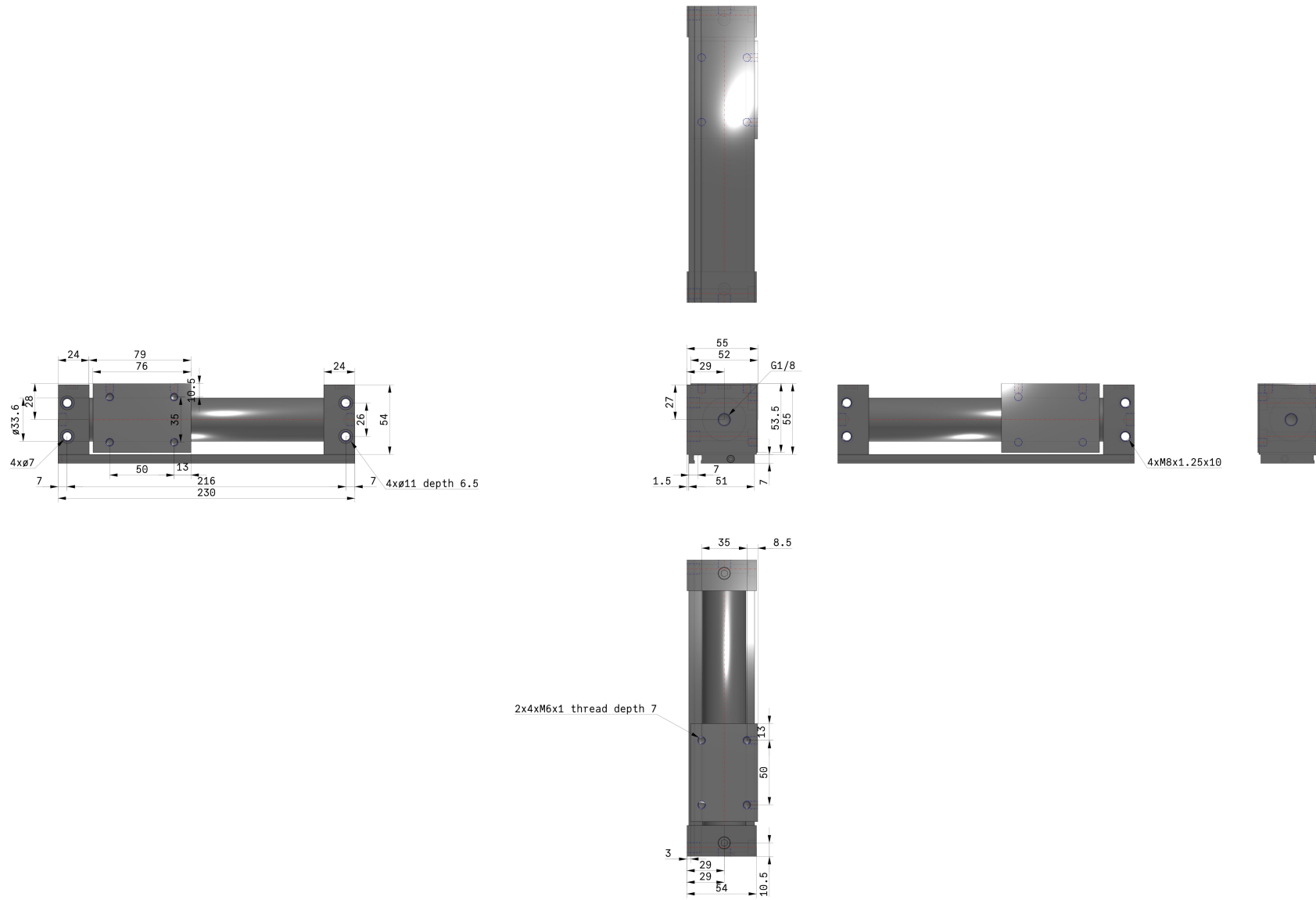

Specifications are subject to change without prior notice and any obligation on the part of the manufacturer.

## Constructions

### Both sides piping type

CY3R15 to 63

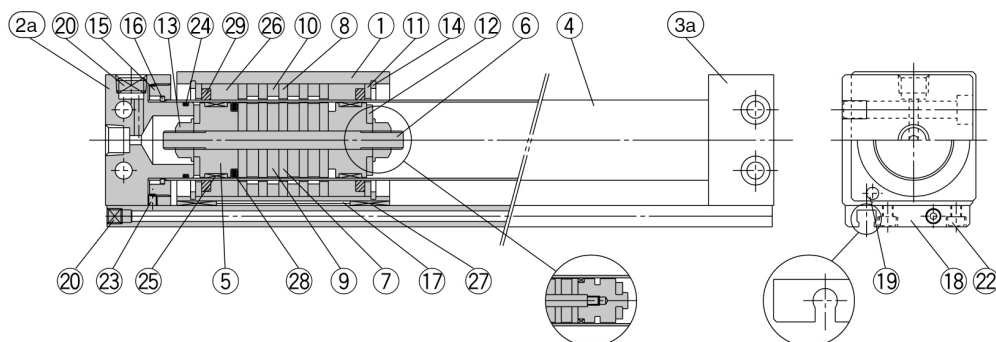

CY3R15, 20

CY3R15

#### Component Parts

No.	Description	Material	Note
1	Body	Aluminum alloy	Hard anodized
2a	End cover A	Aluminum alloy	Electroless nickel plated
2b	End cover C	Aluminum alloy	Electroless nickel plated
3a	End cover B	Aluminum alloy	Electroless nickel plated
3b	End cover D	Aluminum alloy	Electroless nickel plated
4	Cylinder tube	Stainless steel	
5	Piston	ø6 to ø15 Brass	ø6 to ø15 Electroless nickel plated
		ø20 to ø63 Aluminum alloy	ø20 to ø63 Chromate
6	Shaft	Stainless steel	
7	Piston side yoke	Rolled steel plate	Zinc chromated
8	External slider side yoke	Rolled steel plate	Zinc chromated
9	Magnet A	Rare earth magnet	
10	Magnet B	Rare earth magnet	
11	Spacer	Aluminum alloy	Black anodized (ø6: not available)
12	Bumper	Urethane rubber	
13	Piston nut	Carbon steel	Zinc chromate (ø6 to ø15: not available)
14	C type snap ring for hole	Carbon tool steel	Nickel plated
15	Attachment ring	Aluminum alloy	Chromate
16	C type snap ring for shaft	Hard steel wire	
17	Magnetic shielding plate	Rolled steel plate	Chromated (ø6, ø10: not available)
18	Switch rail	Aluminum alloy	White anodized
19	Magnet	Rare earth magnet	
20	Hexagon socket head plug	Chromium steel	Nickel plated

No.	Description	Material	Note
21	Steel balls	Chromium steel	ø40 Hexagon socket head plug
			ø20, ø50, ø63 None
22	Hexagon socket head screw	Chromium steel	Nickel plated
23	Hexagon socket head set screw	Chromium steel	Nickel plated
24*	Cylinder tube Gasket	NBR	
25*	Wear ring A	Special resin	
26*	Wear ring B	Special resin	
27*	Wear ring C	Special resin	
28*	Piston seal	NBR	
29*	Lubretainer	Special resin	
30*	Switch rail gasket	NBR	Both sides piping type: None

\* Seal kits are sets consisting of numbers 24 through 30. Order using the kit number corresponding to each bore size.

## Additional information

Catalogue	<a href="#">CY3-C_EU.pdf</a>
Operation manuals	<a href="#">OM_CYBx_OM0001EN-A.pdf</a> <a href="#">OM_CY3R_OM0001H_EN.pdf</a>