

## C(D)QM, Compact Cylinder, Guide Rod Type CDQMB20-10

### Datasheet

The CQM is a compact cylinder integrated with a guide rod and plate. The series is available in 12, 16, 20, 25, 32, 40, 50, 63, 80 and 100mm bore sizes with the same mounting dimensions as the CQ2. The guide rod and plate allow work to be directly mounted. The CQM series offers 4 times the lateral load resistance of the CQ2K and non-rotating accuracy of  $\pm 0.2^\circ$ .

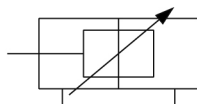

*Double-acting cylinder with cushioning adjustable at both ends, single piston rod*

### Standard specifications

Magnet	D (Built-in)
Mounting	B [Through Hole (Standard)]
Bore Size	Ø20 mm
Port Thread	M Thread
Rc	
Stroke	10mm
Auto Switch	No Switch
Lead Wire or Prewired Connector	0.5 m
Number	2 pcs.
Pressure medium	Compressed air
Maximum temperature of pressure medium with magnet	60 °C
Minimum temperature of pressure medium with magnet	-10 °C (with no freezing)
Maximum operating pressure	1.0 MPa
Minimum operating pressure	0.1 MPa
Proof pressure	1.5 MPa
Maximum ambient temperature with magnet	60 °C
Minimum ambient temperature with magnet	-10 °C (with no freezing)
Number of pneumatic connections	2 pcs.
Pneumatic input connection	M5
Pneumatic exhaust connection	M5

Theoretical cylinder force, advance stroke (at 0.5 MPa)	157
Theoretical cylinder force, return stroke (at 0.5 MPa)	118
Maximum piston speed	500 mm/s
Type of cushioning	Rubber bumper on both ends
Piston rod end	Without thread
Non-rotating accuracy of plate	$\pm 0.1^\circ$
Allowable rotational torque	0.32N·m
Weight	0.138 Kg

## Dimensions

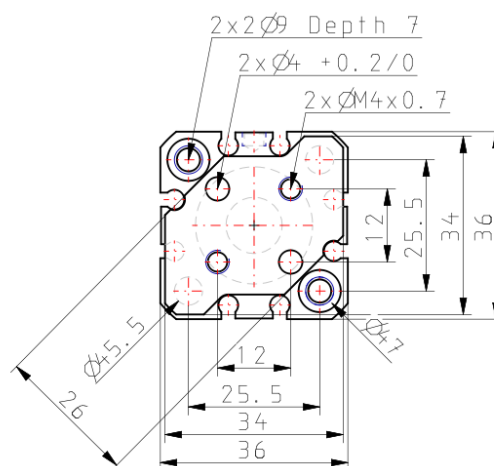
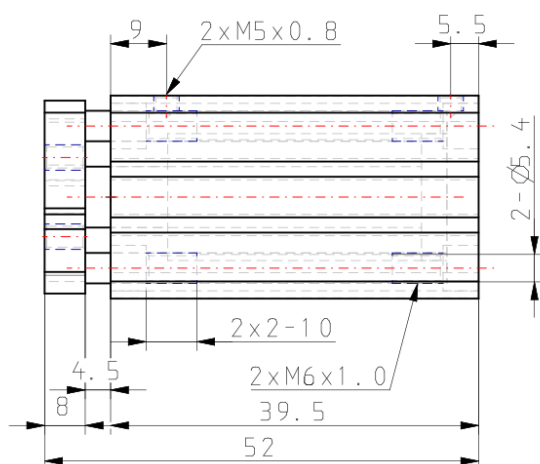

## Constructions

ø12 to ø25

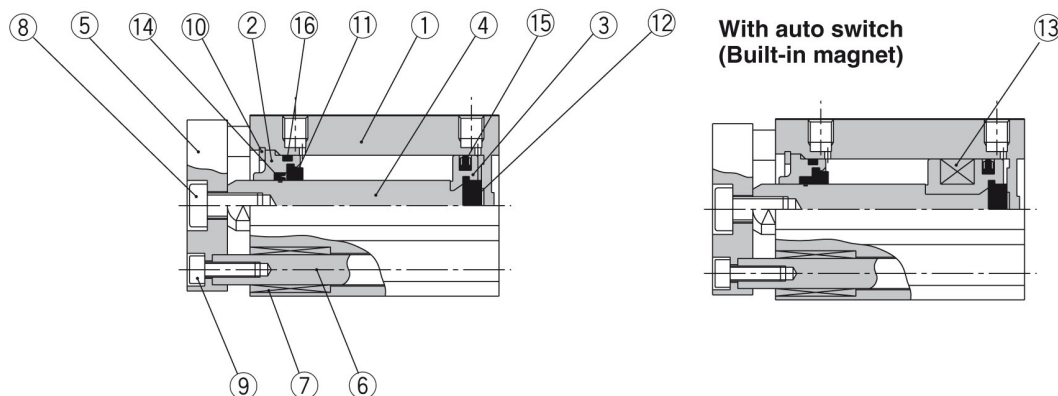

### Component Parts

No.	Description	Material	Note
1	<b>Cylinder tube</b>	Aluminium alloy	Hard anodised
2	<b>Collar</b>	Aluminium alloy	Anodised
3	<b>Piston</b>	Aluminium alloy	Chromated
4	<b>Piston rod</b>	Stainless steel	
5	<b>Plate</b>	Aluminium alloy	Anodized
6	<b>Guide rod</b>	Stainless steel	Hard chrome plated
7	<b>Bushing</b>	Oil-impregnated sintered alloy	
8	<b>Hexagon socket head cap screw</b>	Carbon steel	Nickel plated
9	<b>Hexagon socket head cap screw</b>	Carbon steel	Nickel plated
10	<b>Snap ring</b>	Carbon tool steel	Phosphate coated
11	<b>Bumper A</b>	Urethan	
12	<b>Bumper B</b>	Urethan	
13	<b>Magnet</b>	—	
14	<b>Rod seal</b>	NBR	
15	<b>Piston seal</b>	NBR	
16	<b>Gasket</b>	NBR	

## Additional information

Catalogue

[CQM\\_EU.pdf](#)