



CY3B, Rodless Cylinder, Magnetically Coupled, (Basic) CY3B25TF-1500

Datasheet

- Magnetically coupled rodless cylinder
- Basic Type
- Bore sizes (mm): 6, 10, 15, 20, 25, 32, 40, 50, 63
- Maximum operating pressure: 0.7MPa
- Ambient temperature: -10 to 60°C



Magnetically coupled rodless cylinder

Standard specifications

Bore Size	25mm
Port Thread	TF (G Thread)
Stroke	1500
Made to Order	None
Maximum operating pressure	0.7 MPa
Minimum operating pressure	0.15 MPa
Proof pressure	1.05 MPa
Type of cushioning	Rubber bumper on both ends
Lubrication	Non-lube
Fluid	Air
Ambient and fluid temperature	-10 - 60°C
Stroke length tolerance	0 to 250 st: +1.0/0, 251 to 1000 st: +1.4/0, 1001 st to: +1.8/0
Magnetic holding force	363 N
Piston speed	50 - 500 mm/s
Mounting orientation	Horizontal, Inclined, Vertical
Mounting nut (2 pcs.)	Standard equipment (accessory)
Weight	1.362 Kg

Dimensions

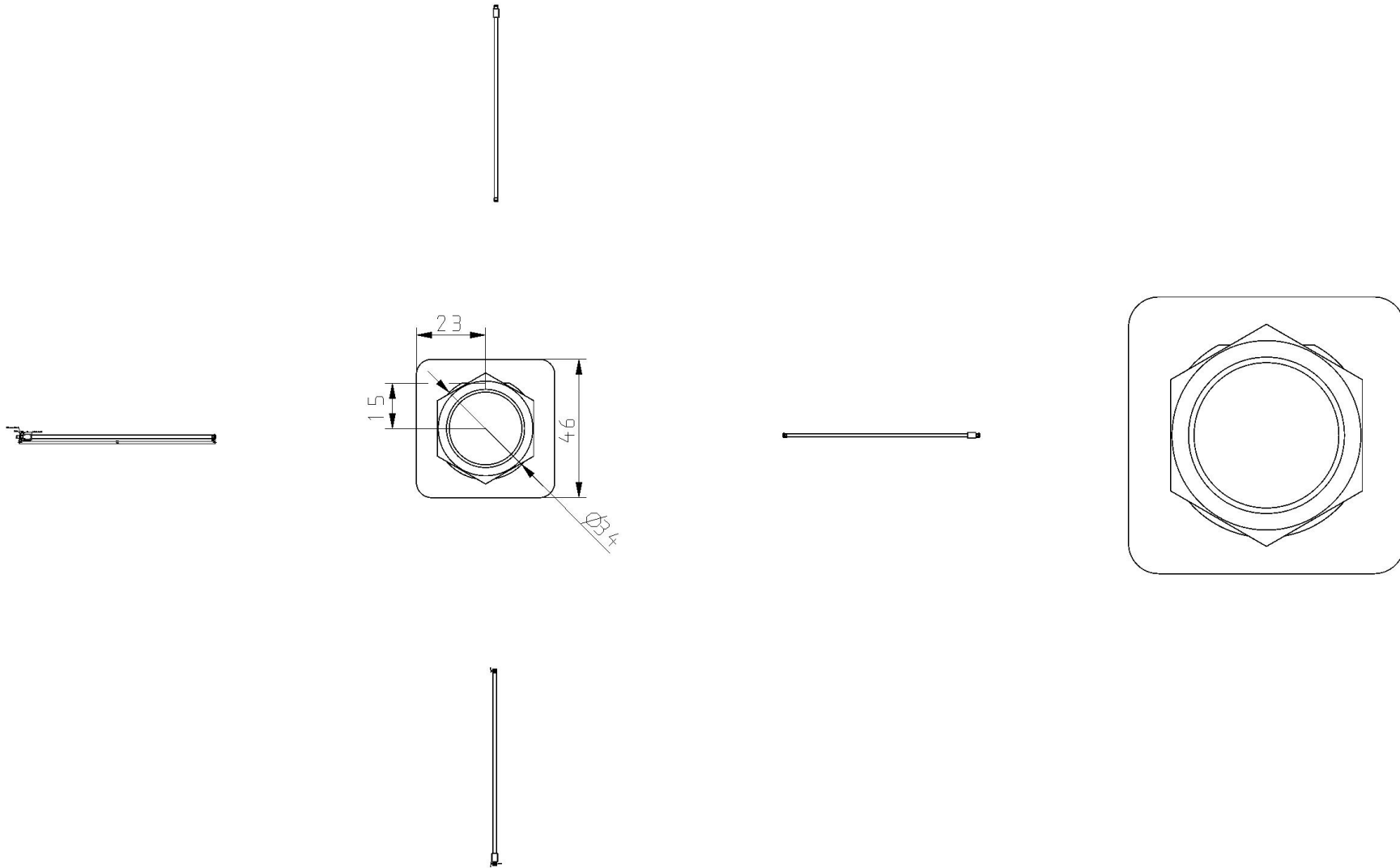

Constructions

CY3B20 to 40

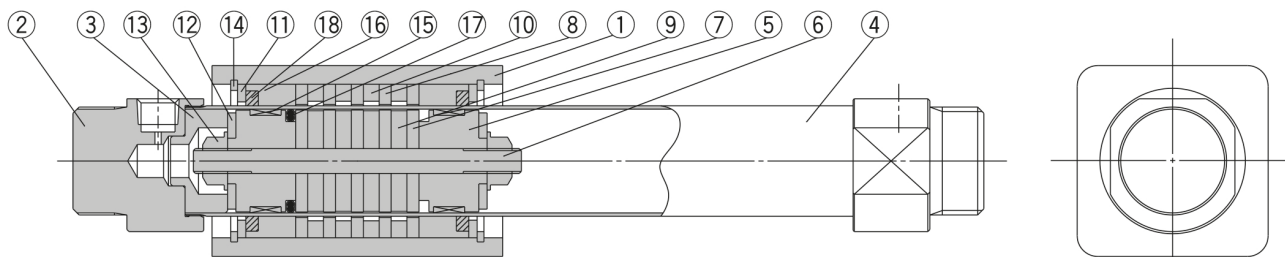

Component Parts

No.	Description	Material	Note
1	Body	Aluminum alloy	Hard anodized
2	Head cover	Ø 6, Ø 10 Brass	Electroless Ni plated
		Ø 15 to Ø 63 Aluminum alloy	
3	End collar	Aluminum alloy	Ø 20 to Ø 40 only
4	Cylinder tube	Stainless steel	
5	Piston	Ø 6 to Ø 15 Brass	Ø 6 to Ø 15 Electroless Ni plated
		Ø 20 to Ø 63 Aluminum alloy	Ø 20 to Ø 63 Chromated
6	Shaft	Stainless steel	
7	Piston side yoke	Rolled steel	Zinc chromated
8	External slider side yoke	Rolled steel	Zinc chromated
9	Magnet A	Rare earth magnet	
10	Magnet B	Rare earth magnet	
11	Spacer	Aluminum alloy	Black anodized (Ø 6: not available)
12	Bumper	Urethane rubber	
13	Piston nut	Carbon steel	Ø 6 to Ø 15: not available
14	C type snap ring for hole	Carbon tool steel	Nickel plated
15	Wear ring A	Special resin	
16	Wear ring B	Special resin	
17	Piston seal	NBR	
18	Lubretainer	Special resin	Ø 6: not available
19	Cylinder tube gasket	NBR	Ø 6, Ø 10 only

Additional information

Catalogue	CY3-C_EU.pdf
Operation manuals	cy3r_cy_r-om0001h-a.pdf cy3b_cy_b-om0001h-a.pdf