

VHK-A, Finger Valve, One-touch Fitting

VHK2A-12F-12FL

Datasheet

General series information

- 1(P)/2(A) One-touch fitting.



Directional control valve 2/2-way valve, closed normal position return with control mechanism by turning return with mechanical control spring

Standard specifications

| | |
|--|---------------------------------|
| Valve | 2 (2-Port Valve) |
| 1(P) Applicable Tubing O.D. | ø 12 |
| 2(A) Applicable Tubing O.D. | ø 12 |
| Knob Colour | Grey (2-port); Blue (3-port) |
| Bracket | L (With L-bracket) |
| Pressure medium | Air |
| Maximum temperature of pressure medium | 60 °C |
| Minimum temperature of pressure medium | 0 °C |
| Maximum operating pressure | 1.0 MPa |
| Minimum operating pressure | -100 kPa |
| Proof pressure | 1.5 MPa |
| Maximum ambient temperature | 60 °C |
| Minimum ambient temperature | 0 °C |
| Usable tubing material | Nylon, Soft nylon, Polyurethane |
| Weight | 0.045 Kg |

Dimensions

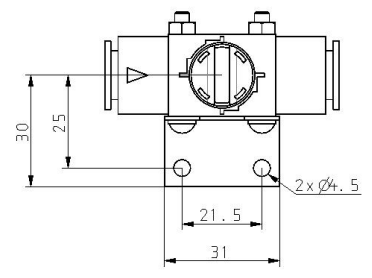
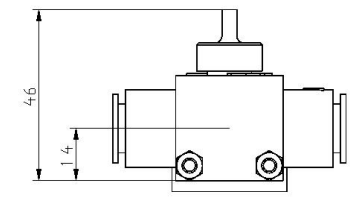
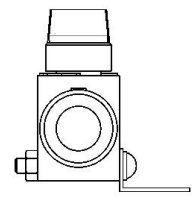
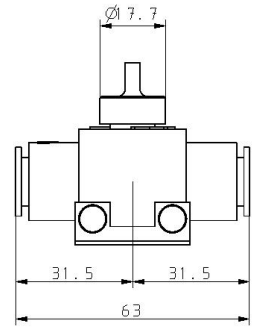
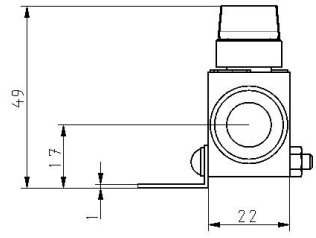
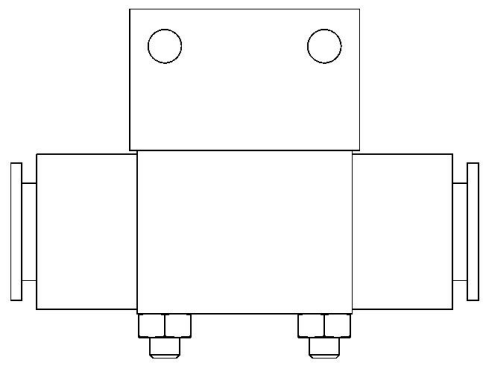

Specifications are subject to change without prior notice and any obligation on the part of the manufacturer.

Constructions

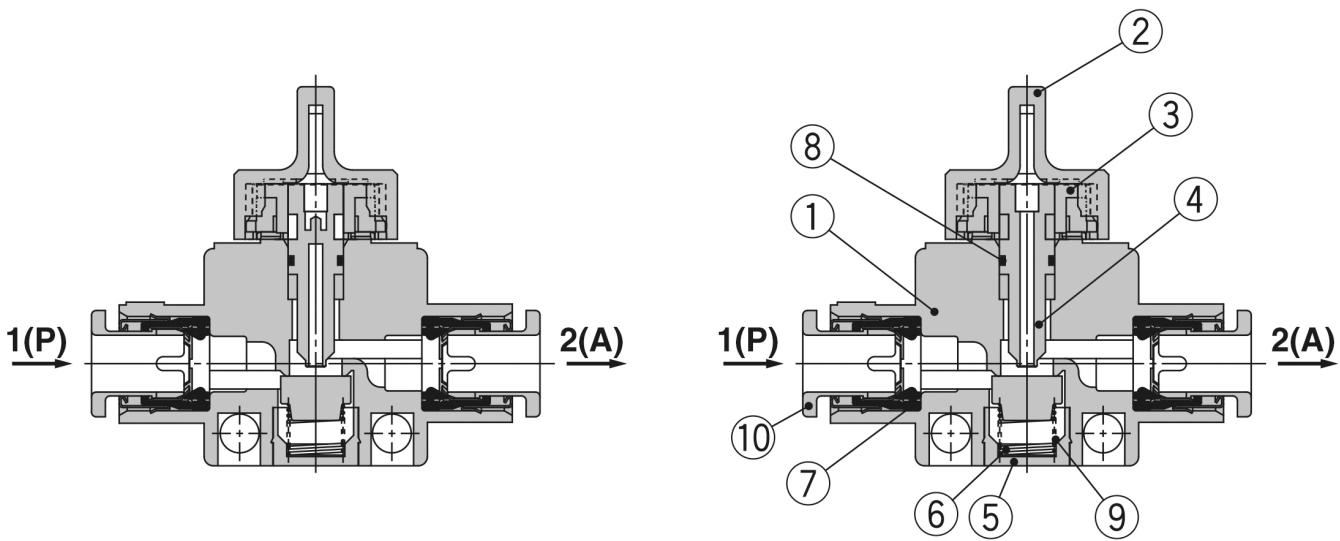

| No. | Description | Material | Note |
|-----|---------------------|-----------------|---------------------------|
| 1 | Body | PBT | |
| 2 | Knob | POM | |
| 3 | Cam ring | POM | |
| 4 | Stem | POM | |
| 5 | Spring guide | Brass | Electroless nickel plated |
| 6 | Spring | Stainless steel | |
| 7 | Seal | NBR | |
| 8 | O-ring | NBR | |
| 9 | Valve | NBR | |
| 10 | Cassette | — | |

Additional information

Catalogue

[VHK-Aa_EU.pdf](#)