

C(D)QS, Compact Cylinder, Double Acting, Single Rod CDQSB16-30DM

Datasheet

The CQS compact cylinder is available for those small bore cylinder applications where saving space is a concern. While sharing many of the outstanding features of the CQ2 series, the CQS offers standard long strokes (up to 300mm) in four bore sizes from 12 to 25mm. Long stroke versions incorporate a wear band and thicker piston to handle the increased bearing needs of the longer strokes. Both switch capable and non-switch capable body styles are the same, and switches can be mounted on three (12-16 bore) and four (20-25 bore) sides. An increased side load version (CQS*S) is available for more demanding applications.

Magnet	D (Built-in)
Mounting	B (Through Hole, Both Ends Tapped)
Bore Size	Ø16 mm
Lube-retainer	Without Stable Lubrication Function
Stroke	30
Option	M (Rod End Male Thread)
Auto Switch	No Switch
Lead Wire or Prewired Connector	0.5 m (Or None in the Case of No Switch)
Number	2 pcs.
Dust Resistant	None
Rod End Options	None
Pressure medium	Air
Conform to the European RoHS Directive	Conform
Numero of pneumatic connections	2 pcs.
Mode of operation of drive	Double acting
Geometric form of the piston rod	Round piston rod
Weight	0.110 Kg

Dimensions

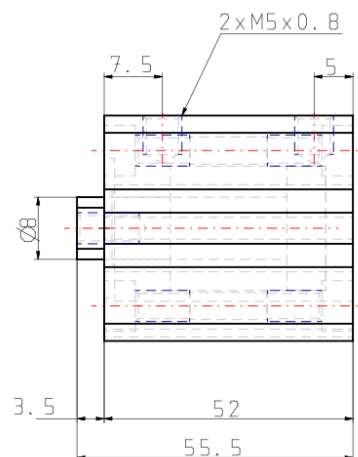
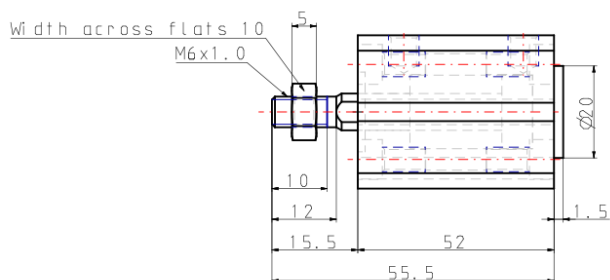

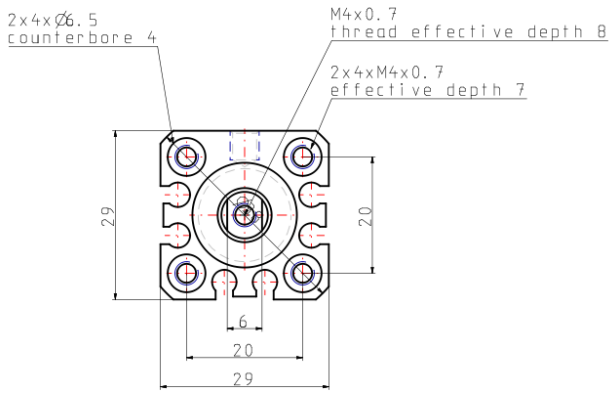

Additional information

Catalogue

[CQS_EU.pdf](#)