



**Compact Direct Operated
2/3 Port Solenoid Valve For Water and Air**

Series *VDW*

VDW10/20/30: 2 Port, VDW200/300: 3 Port



New Molded coil specifications have been added!



Grommet



Faston™ terminal

Compact / Lightweight
(compared to the VX series)

Single valve volume: Reduced by -75% (VDW20)
100 g: Reduced approx. by -50%
(for an orifice size equivalent to \varnothing 2mm)

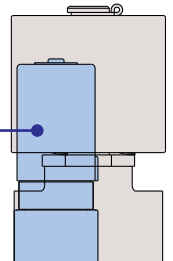

Compact Direct Operated 2/3 Port Solenoid Valve For Water and Air

Series VDW

- **Compact (compared to the VX series)**

Single valve volume: **Reduced by -75%** (VDW20)

Manifold length: **Reduced by -18%** (VDW30, 7 stations)

- **Lightweight (compared to the VX series)**

100 g: Reduced approx. by -50%

(for an orifice size equivalent to \varnothing 2mm)

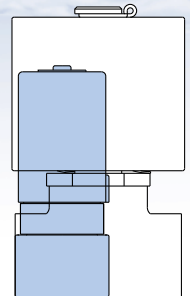

Improved durability (Nearly twice the life of the previous series)

The use of a unique magnetic material reduces the operating resistance of moving parts, while improving service life, wear and corrosion resistance.

Improved corrosion resistance

Special material introduced.

**High flow rate: Cv factor
0.04 to 0.46 (2 port)**

**Universal porting
VDW200/300 (3 port)**

New

Improved environment resistance

Environment resistance is improved by using a molded coil. (Enclosure IP65 or equivalent, grommet mold)

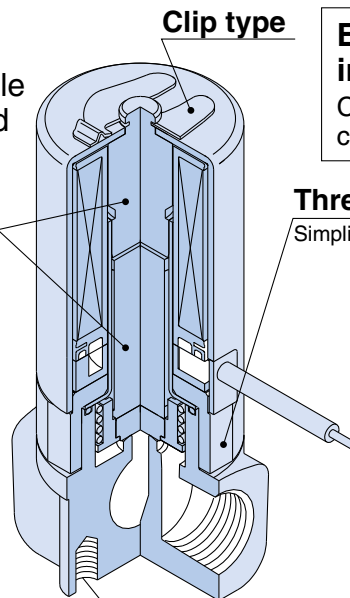

Ease of maintenance has been improved.

Changing the coil is made easy with a clip design. (2 port)

Threaded assembly

Simplifies maintenance.

Brass (37)/Stainless steel manifolds added to series (2 port)

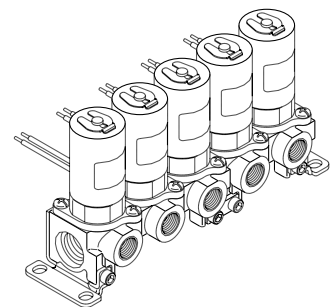

Threaded for bottom mounting

A special bracket can be mounted.

Lineup by Compact Design

2 Port			3 Port	
\varnothing 17	\varnothing 20.5	\varnothing 28	\varnothing 20.5	\varnothing 28
VDW10	VDW20	VDW30	VDW200	VDW300

Compact Direct Operated 2 Port Solenoid Valve For Water and Air Series **VDW10/20/30**



How to Order Valves (Single unit)

VDW **2** **1** - **1** **G** - **2** - **01** - - - - - **Q**

For Water, Air, Vacuum

Made to Order
(Refer to page 2.)

Option

-	None
F	Foot bracket

Note) The foot bracket is packed with a valve.

Material and insulation type

Symbol	Body material	Seal material	Coil insulation
-	Brass (C37)	NBR	Class B
A		FKM	
B		EPDM	
G	Stainless steel	NBR	
H		FKM	
J		EPDM	
L <small>Note)</small>		FKM	

Note) For deionized water: the armature assembly is a corrosion resistant construction.

Thread type

-	Rc
F	G
N	NPT

Port size

Symbol	Port size	Series		
		10	20	30
M5	M5	○	○	—
01	1/8 (6A)	—	○	○
02	1/4 (8A)	—	—	○

Orifice size

Symbol	Orifice diameter (mm ø)	Series
1	1	10
2	1.6	
1	1.6	20
2	2.3	
3	3.2	30
2	2	
3	3	
4	4	

Series

1	10
2	20
3	30

Valve type

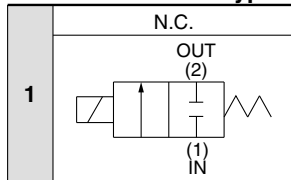

Voltage

Symbol	Voltage	Grommet / Tape winding	Faston™ terminal, Molded	Grommet / Molded
1	100 VAC (50/60 Hz)	●	—	●
2	200 VAC (50/60 Hz)	●	—	●
3	110 VAC (50/60 Hz)	●	—	●
4	220 VAC (50/60 Hz)	●	—	●
5	24 VDC	●	●	●
6	12 VDC	●	●	●
V	6 VDC	●	●	●
S	5 VDC	●	●	●
R	3 VDC	●	●	●

* Please consult with SMC regarding other voltages.

Electrical entry

G – Grommet / Tape winding	W – Grommet / Molded
Magnet wire protection: Tape winding	Magnet wire protection: Molded
F – Faston™ terminal / Molded	
Magnet wire protection: Molded	

Series and Coil Type Combinations

Series	Grommet / Tape winding	Faston™ terminal / Molded	Grommet / Molded
10	●	—	●
20	●	●	●
30	●	●	●



Standard Specifications

Valve specifications		Valve construction	Direct operated poppet
Valve specifications	Fluid ^{Note 2)}	Withstand pressure (MPa)	Water (except waste water or agricultural water), Air, Low vacuum
	Withstand pressure (MPa)	Ambient temperature (°C)	2.0
	Ambient temperature (°C)	Fluid temperature (°C)	-10 to 50
	Fluid temperature (°C)	Environment	1 to 50 (No freezing)
	Environment	Valve leakage (cm ³ /min)	Location without corrosive or explosive gases
	Valve leakage (cm ³ /min)	Mounting orientation	0 (with water pressure) / 1 (Air)
	Mounting orientation	Vibration/Impact (m/s ²) ^{Note 4)}	Unrestricted
	Vibration/Impact (m/s ²) ^{Note 4)}		30/150
Coil specifications		Rated voltage	24 VDC, 12 VDC, 6 VDC, 5 VDC, 3 VDC, 100 VAC, 110 VAC, 200 VAC, 220 VAC (50/60 Hz)
Coil specifications	Allowable voltage fluctuation (%)	Coil insulation type	±10% of rated voltage
	Enclosure	Grommet / Tape winding	Class B
		Faston™ terminal / Molded	Dust-proof (equivalent to IP40)
		Grommet / Molded	Dust-tight (equivalent to IP60) ^{Note 5)}
Power consumption (W) ^{Note 3)}		Dust-tight / Low jetproof (equivalent to IP65)	
		Power consumption (W) ^{Note 3)}	2.5 (VDW10), 3 (VDW20/30)



Note 1) When used under conditions which may cause condensation on the exterior of the product, select Grommet / Molded.

Note 2) When used with deionized water, select "L" (Stainless steel, FKM) for the material and insulation type.

Note 3) Since the AC coil specification includes a rectifier element, there is no difference in power consumption between inrush and holding.

In case of 110/220 VAC, the power consumption for the VDW10 model is 3W and 3.5W for the VDW20/30.

Note 4) Vibration resistance No malfunction when tested with one sweep of 5 to 200 Hz in the axial direction and at a right angle to the armature, in both energised and deenergised states.

Impact resistance No malfunction when tested with a drop tester in the axial direction and at a right angle to the armature, one time each in energised and deenergised states.

Note 5) Since electrical connections are exposed, there is no water resistance.



Made to Order

(For details, refer to page 17.)

Symbol	Specifications
X22	Non-leak (10 ⁻⁶ Pa·m ³ /sec) / Vacuum (0.1Pa-abs) specification
X23	Oil-free specification
X60	Lead wire length: 600 mm specification
X133	Seal material: FFKM

Characteristic Specifications

Model	Port size	Orifice dia. (mm ø)	Max. operating pressure differential (MPa) ^{Note 1)}		Operating Pressure range (MPa) ^{Note 2)}	Weight (kg)	
			Pressure port 1	Pressure port 2			
VDW10	M5	1	0.9	0.4	0 to 1.0	0.08	
		1.6	0.4	0.2			
VDW20	M5 1/8 (6A)	1.6	0.7	0.2		0 to 1.0	0.1
		2.3	0.4	0.1			
		3.2	0.2	0.05			
VDW30	1/8 (6A) 1/4 (8A)	2	0.8	0.2		0 to 1.0	1/8: 0.23 1/4: 0.26
		3	0.4	0.1			
		4	0.2	0.05			



Note 1) The maximum operating pressure differential changes depending on the fluid flow direction. Refer to back page 6 for details.

Note 2) For low vacuum specifications, the operating pressure range is 1 Torr (1.33 x 10² Pa) to 1.0 MPa. Please consult with SMC if using below 1 Torr (1.33 x 10² Pa).

Flow Characteristics

Model	Port size	Orifice dia. (mm ø)	Water		Air		
			1→2 (IN→N.C.)		1→2 (IN→N.C.)		
			N.C.	Av x 10 ⁻⁶ m ²	Cv converted	C [dm ³ /(s·bar)]	b
VDW10	M5	1	0.96	0.04	0.14	0.40	0.04
		1.6	1.7	0.07	0.30	0.25	0.07
VDW20	M5 1/8 (6A)	1.6	1.9	0.08	0.31	0.45	0.09
		2.3	4.3	0.18	0.58	0.45	0.18
		3.2	7.2	0.30	1.2	0.38	0.33
VDW30	1/8 (6A) 1/4 (8A)	2	3.8	0.16	0.52	0.52	0.16
		3	6.7	0.28	1.0	0.52	0.30
		4	11	0.44	1.5	0.49	0.46

**Compact Direct Operated
2 Port Solenoid Valve For Water and Air Series VDW10/20/30**

Construction

VDW11

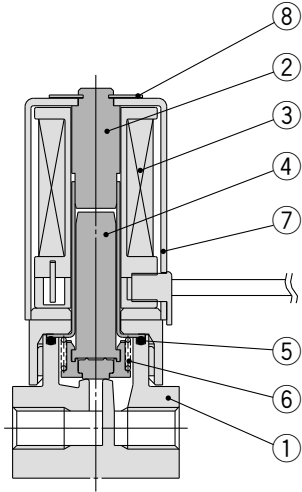

VDW21

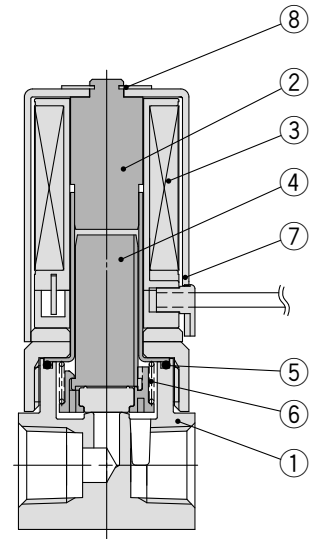

VDW31

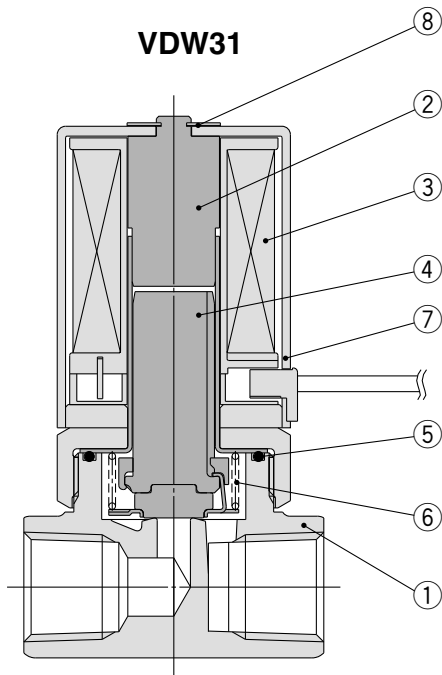

Component Parts

No.	Description	Material	
		Standard	Option
1	Body	Brass (C37)	Stainless steel
2	Tube assembly	Stainless steel	—
3	Coil assembly	—	—
4	Armature assembly	Stainless steel, PPS, NBR	Stainless steel, PPS, FKM, EPDM
5	O-ring (Body)	NBR	FKM, EPDM
6	Return spring	Stainless steel	—
7	Cover	Steel (SPCE)	—
8	Clip	Stainless steel	—

Series VDW10/20/30

Dimensions

VDW11-□^G_W

VDW21-□^G_W

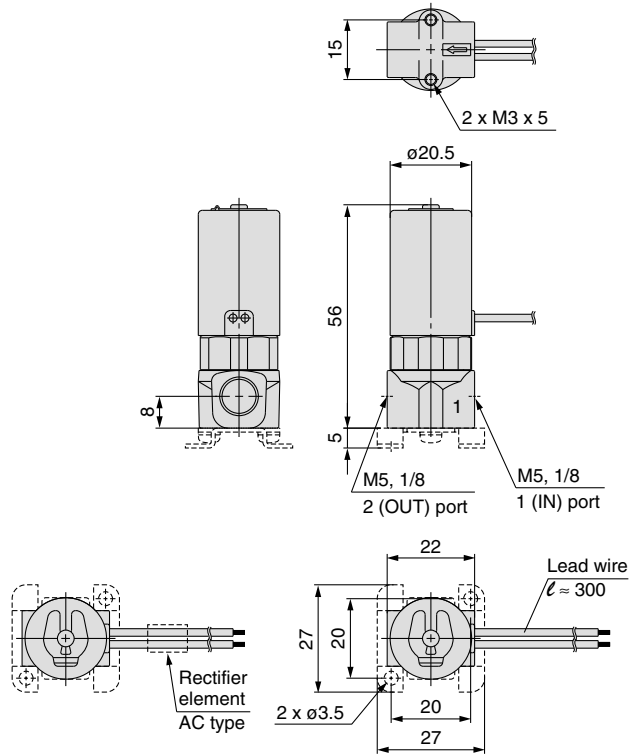
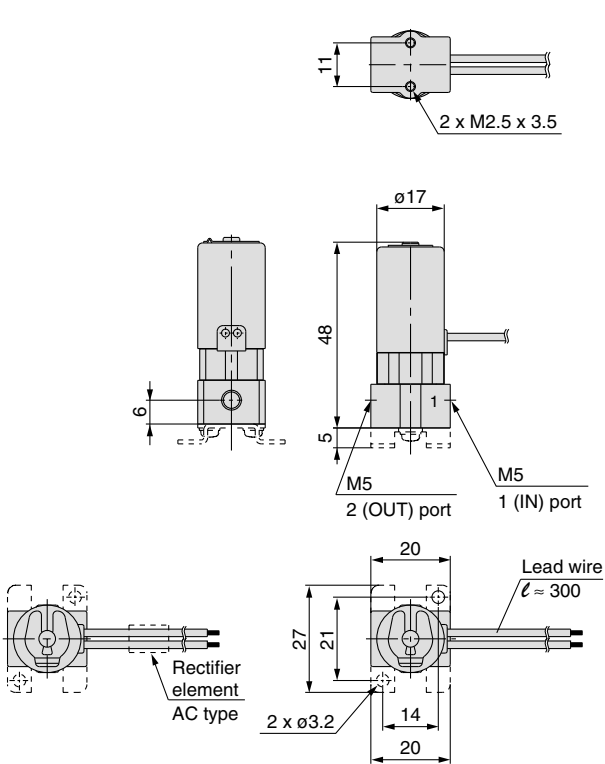

VDW31-□^G_W

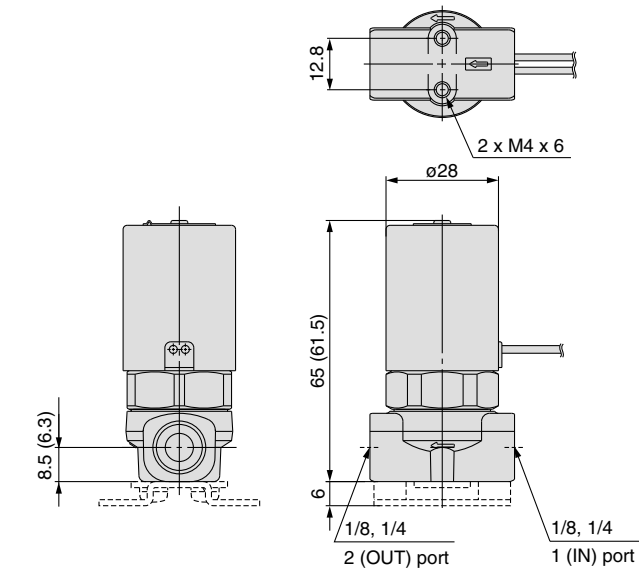

Dimensions inside () are for port size 1/8.

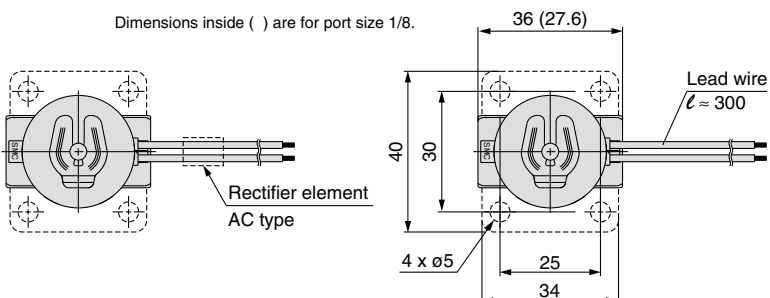

Bracket assembly part no.

• Series 10, 20

VDW 2 0-15A-1

• Series

1	10
2	20

• Series 30

VCW20-12-01A

**Compact Direct Operated
2 Port Solenoid Valve For Water and Air Series VDW10/20/30**

Dimensions

VDW21-□F

VDW31-□F

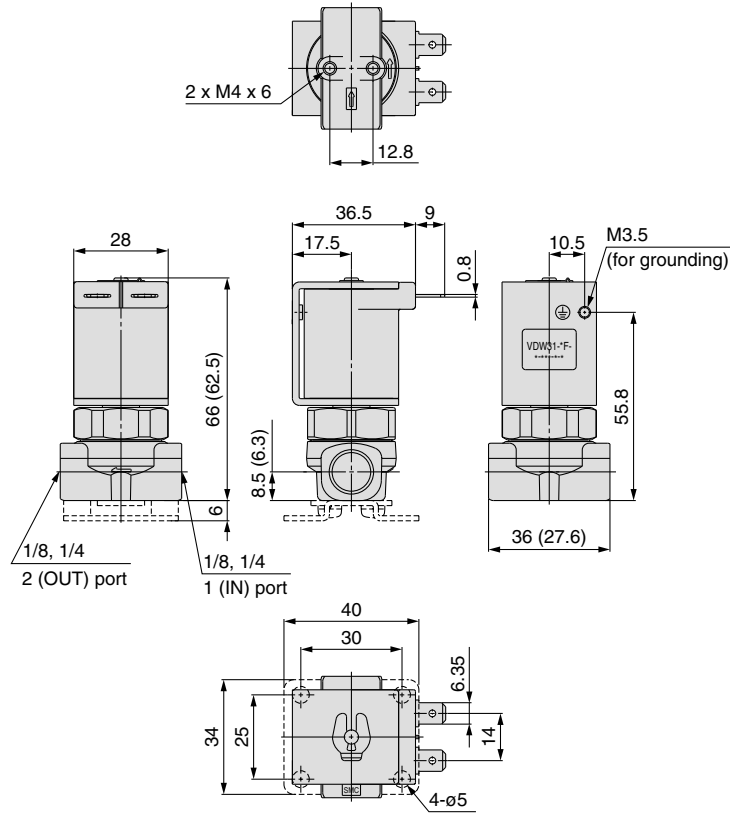
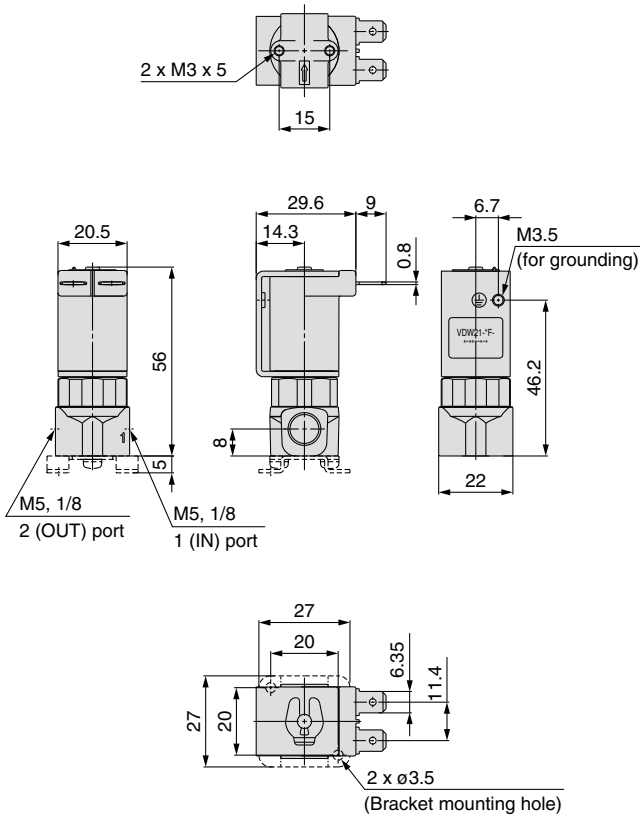

Bracket assembly part no.

- Series 20

VDW20 – 15A – 1

- Series 30

VCW20 – 12 – 01A

Compact Direct Operated 2 Port Solenoid Valve For Water and Air *Series VDW10/20/30*

Dimensions

VV2DW1

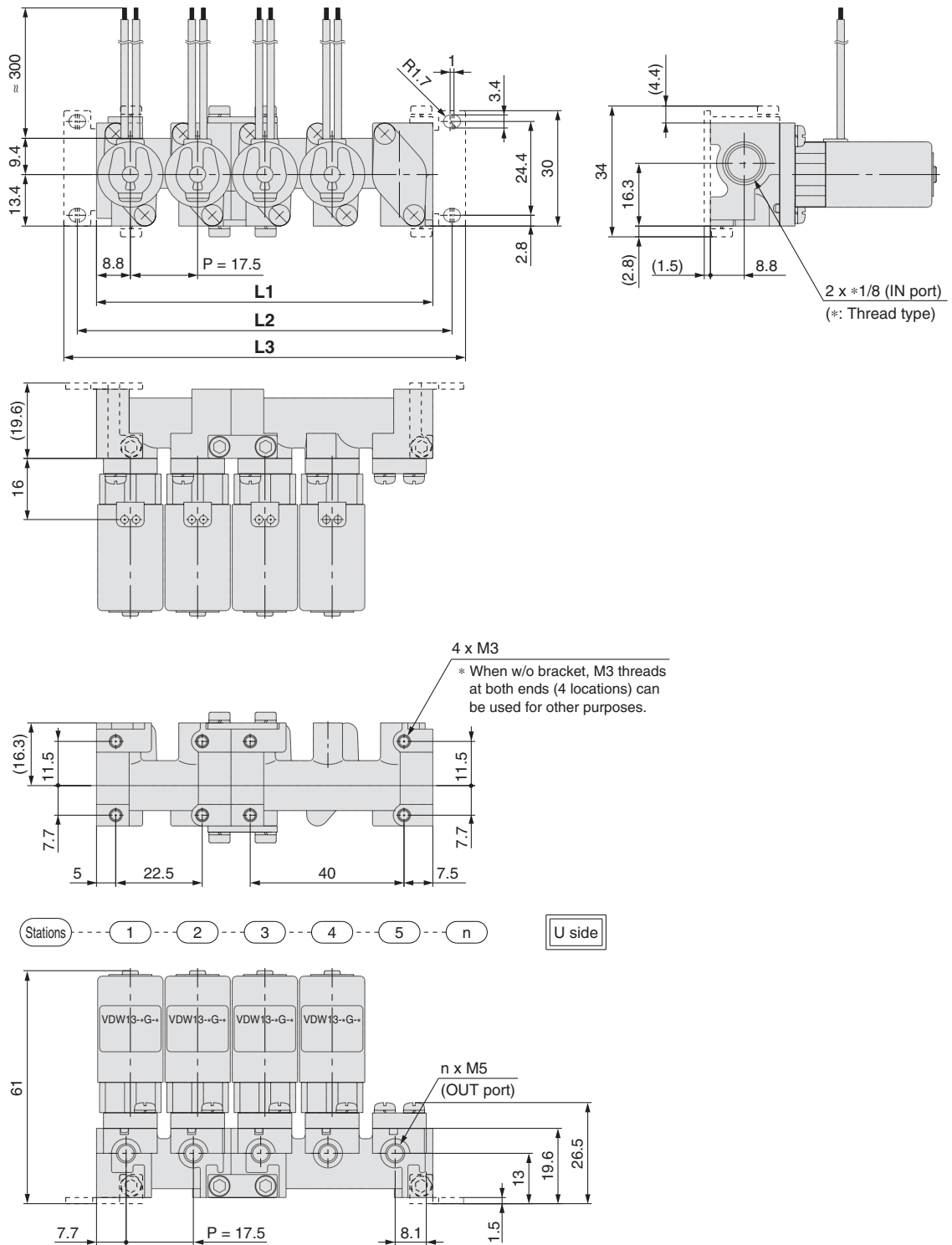

L Dimension

Dimension	n (stations)									
	2	3	4	5	6	7	8	9	10	
L1	35	52.5	70	87.5	105	122.5	140	157.5	175	
L2	45	62.5	80	97.5	115	132.5	150	167.5	185	
L3	52	69.5	87	104.5	122	139.5	157	174.5	192	
Manifold composition	2 stns. x 1	3 stns. x 1	2 stns. x 2	2 stns. + 3 stns.	3 stns. x 2	2 stns. x 2 + 3 stns.	2 stns. + 3 stns. x 2	3 stns. x 3	2 stns. x 2 + 3 stns. x 2	

Note) The manifold base consists of a junction of 2 and 3 station bases.
Refer to page 10 and 11 regarding manifold additions.

Series VDW10/20/30

Dimensions

VV2DW2

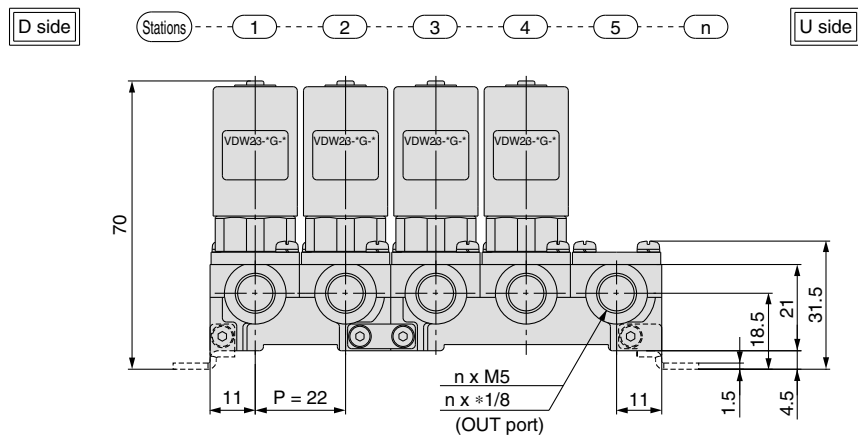
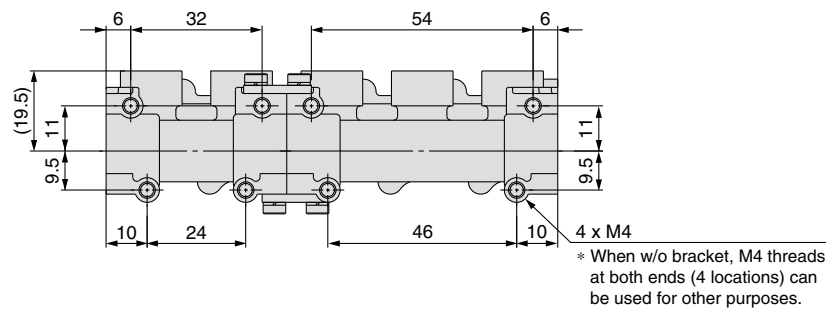
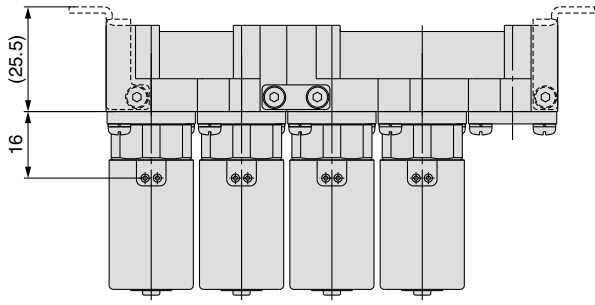
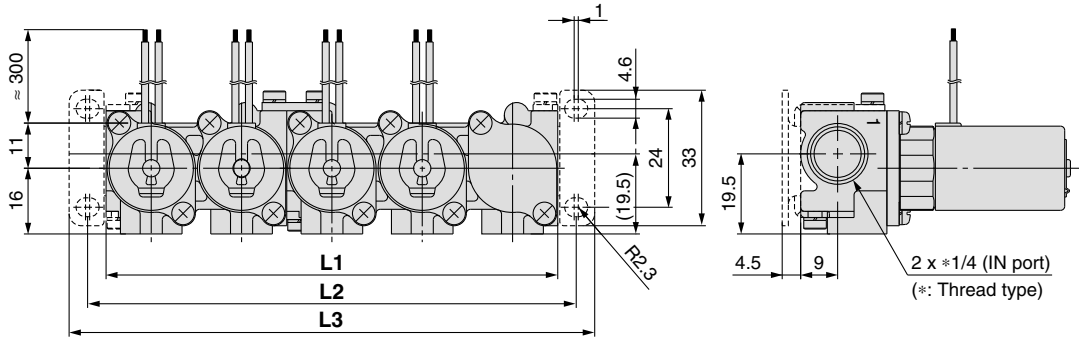

L Dimension

Dimension	n (stations)									
	2	3	4	5	6	7	8	9	10	
L1	44	66	88	110	132	154	176	198	220	
L2	53	75	97	119	141	163	185	207	229	
L3	62	84	106	128	150	172	194	216	238	
Manifold composition	2 stns. x 1	3 stns. x 1	2 stns. x 2	2 stns. + 3 stns.	3 stns. x 2	2 stns. x 2 + 3 stns.	2 stns. + 3 stns. x 2	3 stns. x 3	2 stns. x 2 + 3 stns. x 2	

Note) The manifold base consists of a junction of 2 and 3 station bases. Refer to page 10 and 11 regarding manifold additions.

Compact Direct Operated 2 Port Solenoid Valve For Water and Air *Series VDW10/20/30*

VV2DW3

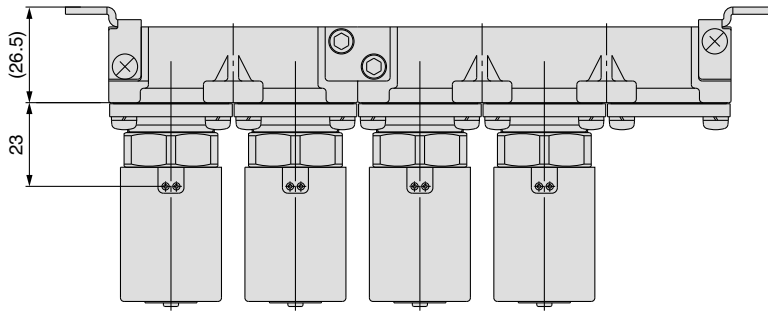
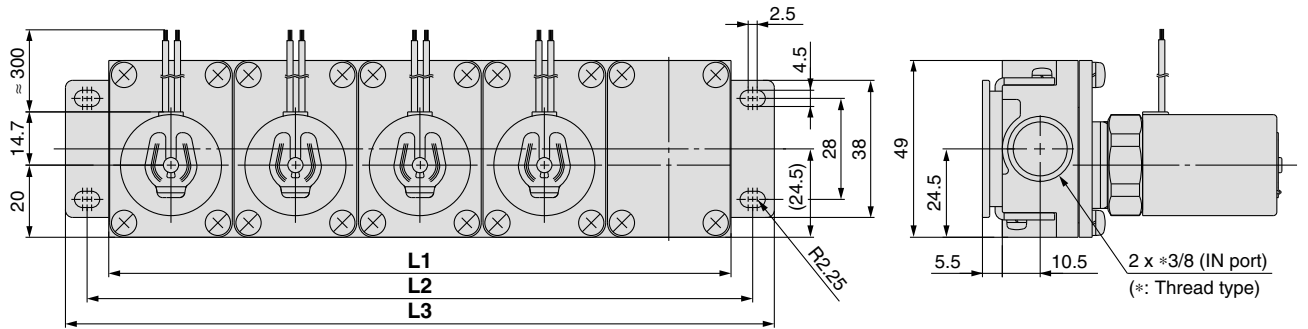
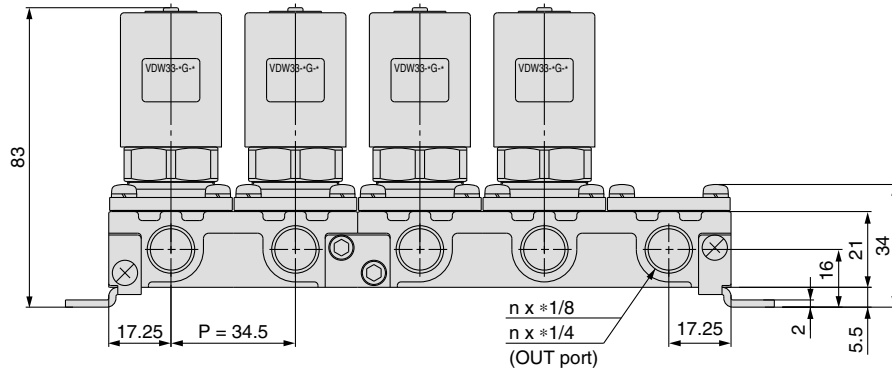
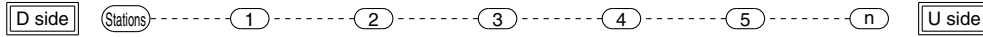

L Dimension

(mm)

Dimension	n (stations)									
	2	3	4	5	6	7	8	9	10	
L1	69	103.5	138	172.5	207	241.5	276	310.5	345	
L2	81	115.5	150	184.5	219	253.5	288	322.5	357	
L3	93	127.5	162	196.5	231	265.5	300	334.5	369	
Manifold composition	2 stns. x 1	3 stns. x 1	2 stns. x 2	2 stns. + 3 stns.	3 stns. x 2	2 stns. x 2 + 3 stns.	2 stns. + 3 stns. x 2	3 stns. x 3	2 stns. x 2 + 3 stns. x 2	

Note) The manifold base consists of a junction of 2 and 3 station bases.
Refer to page 10 and 11 regarding manifold additions.

Manifold Exploded View

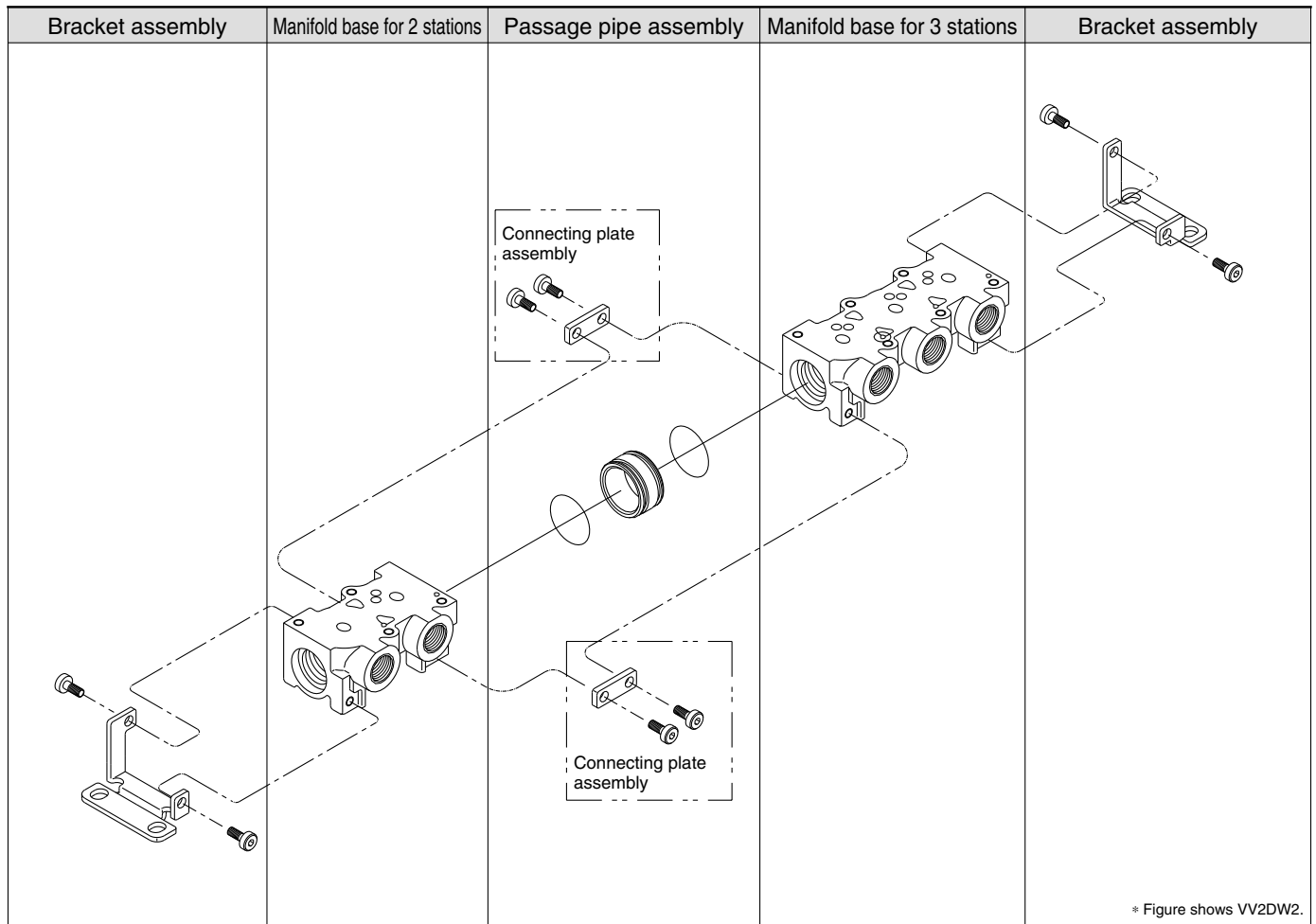

Manifold additions

- 1 Install a passage pipe assembly in between the manifold bases to be added.
- ↓
- 2 Connect the respective manifold bases with a connecting plate assembly. (Tightening torque: 0.9 ± 0.1 N·m)
- ↓
- 3 Attach brackets to the manifold bases. {when equipped with brackets} (Tightening torque: 0.9 ± 0.1 N·m)

Note) The manifold can be increased in 2 or 3-station units.
 A manifold base, a connection plate assembly and a passage pipe assembly are required for each manifold increment.

Compact Direct Operated 2 Port Solenoid Valve For Water and Air *Series VDW10/20/30*

<Manifold base>

- Series 10, 20

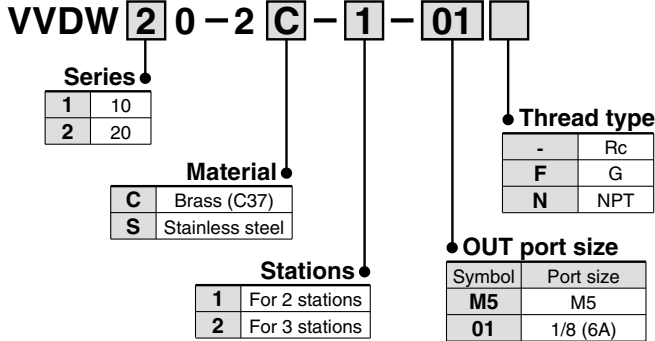

* Series 10 is available with M5 only.

- Series 30

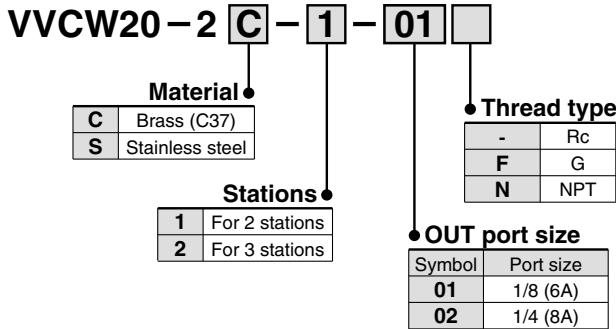

<Bracket assembly>

- Series 10, 20

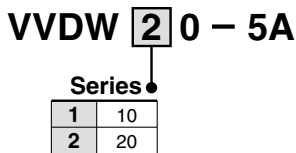

 Note) Consists of a set for D and U sides.

- Series 30

VVCW20-5A

<Connecting plate assembly>

- Series 10, 20

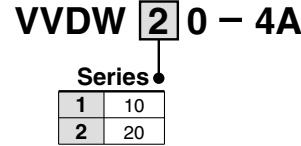

 Note) Consists of two sets of connecting plate and mounting screws.

- Series 30

VVCW20-4A

<Passage pipe assembly>

- Series 10, 20

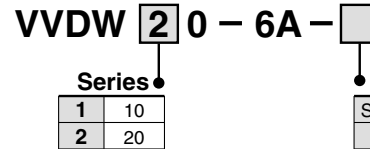

Material

Symbol	Pipe material	Seal material
-		NBR
A	Brass (C37)	FKM
B		EPDM
G		NBR
H	Stainless steel	FKM
J		EPDM

- Series 30

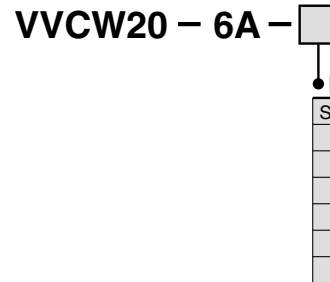

Compact Direct Operated 3 Port Solenoid Valve For Water and Air Series **VDW200/300**



How to Order Valves (Single unit)

VDW 2 50 - 1 G - 2 - 01 - - - - - Q

For Water, Air, Vacuum

Series

2	200
3	300

Valve type

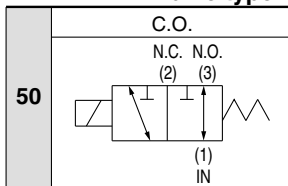

Made to Order
(Refer to page 13.)

Option

-	None
F	Foot bracket



Note) The foot bracket is packed with a valve.

Material and insulation type

Symbol	Body material	Seal material	Coil insulation
-	Brass (C37)	NBR	Class B
A		FKM	
B		EPDM	
G	Stainless steel	NBR	
H		FKM	
J		EPDM	
L (Note)		FKM	



Note) For deionized water: The armature assembly is a corrosion resistant construction.

Voltage

Symbol	Voltage	Grommet / Tape winding	Faston™ terminal, Molded	Grommet / Molded
1	100 VAC (50/60 Hz)	●	—	●
2	200 VAC (50/60 Hz)	●	—	●
3	110 VAC (50/60 Hz)	●	—	●
4	220 VAC (50/60 Hz)	●	—	●
5	24 VDC	●	●	●
6	12 VDC	●	●	●
V	6 VDC	●	●	●
S	5 VDC	●	●	●
R	3 VDC	●	●	●

* Please consult with SMC regarding other voltages.

Thread type

-	Rc
F	G
N	NPT

Electrical entry

G – Grommet / Tape winding	W – Grommet / Molded
<p>Magnet wire protection: Tape winding</p>	<p>Magnet wire protection: Molded</p>
<p>F – Faston™ terminal / Molded</p> <p>Magnet wire protection: Molded</p>	

Port size

Symbol	Port size	Series	
		200	300
M5	M5	○	—
01	1/8 (6A)	○	○
02	1/4 (8A)	—	○

Orifice size

Symbol	N.C. Orifice diameter (mm ø)	N.O. Orifice diameter (mm ø)	Series
1	1	1	200
2	1.6		
2	2		
3	3	1.8	300
4	4		

Compact Direct Operated 3 Port Solenoid Valve For Water and Air *Series VDW200/300*

Standard Specifications



Valve specifications	Valve construction		Direct operated poppet
	Fluid ^{Note 2)}		Water (except waste water or agricultural water), Air, Low vacuum
	Withstand pressure (MPa)		2.0
	Ambient temperature (°C)		-10 to 50
	Fluid temperature (°C)		1 to 50 (No freezing)
	Environment		Location without corrosive or explosive gases
	Valve leakage (cm³/min)		0 (with water pressure) / 1 (Air)
	Mounting orientation		Unrestricted
	Vibration/Impact (m/s²) ^{Note 4)}		30/150
Coil specifications	Rated voltage		24 VDC, 12 VDC, 100 VAC, 110 VAC, 200 VAC, 220 VAC (50/60 Hz)
	Allowable voltage fluctuation (%)		±10% of rated voltage
	Coil insulation type		Class B
	Enclosure	Grommet / Tape winding	Dust-proof (equivalent to IP40)
		Faston™ terminal / Molded	Dust-tight (equivalent to IP60) ^{Note 5)}
		Grommet / Molded	Dust-tight / Low jetproof (equivalent to IP65)
Power consumption (W) ^{Note 3)}		3	



- Note 1) Please consult SMC when used under conditions which may cause condensation on the exterior of the product.
- Note 2) When used with deionized water, select "L" (Stainless steel, FKM) for the material and insulator type.
- Note 3) Since the AC coil specification includes a rectifier element, there is no difference in power consumption between inrush and holding.
3.5 W in the case of 110/220 VAC
- Note 4) Vibration resistance No malfunction when tested with one sweep of 5 to 200 Hz in the axial direction and at a right angle to the armature, in both energised and deenergised states.
Impact resistance No malfunction when tested with a drop tester in the axial direction and at a right angle to the armature, one time each in energised and deenergised states.
- Note 5) Since electrical connections are exposed, there is no water resistance.



Made to Order
(For details, refer to page 17.)

Symbol	Specifications
X22	Non-leak (10 ⁻⁶ Pa·m ³ /sec) / Vacuum (0.1Pa-abs) specification
X23	Oil-free specification
X60	Lead wire length: 600 mm specification
X133	Seal material: FFKM

Characteristic Specifications

Model	Port size	Orifice dia. (mm ø)	Max. operating pressure differential (MPa) ^{Note 2)}		Operating pressure range (MPa) ^{Note 3)}	Weight (kg)
			Pressure port 1	Pressure port 2, 3 ^{Note 1)}		
VDW200	M5 1/8 (6A)	1	0.9	0.3	0 to 1.0	0.12
		1.6	0.7	0.1		
VDW300	1/8 (6A) 1/4 (8A)	2	0.8	0.2		1/8: 0.27 1/4: 0.30
		3	0.4	0.1		
		4	0.2	0.05		



- Note 1) Indicates the maximum operating pressure differential of pressure ports 2 and 3.
- Note 2) The maximum operating pressure differential changes depending on the flow direction of the fluid. Refer to back page 16 for details.
- Note 3) For low vacuum specifications, the operating pressure range is 1 Torr (1.33 x 10² Pa) to 1.0 MPa. Please consult with SMC if using below 1 Torr (1.33 x 10² Pa).

Flow Characteristics

Model	Port size	Orifice dia. (mm ø)		Water				Air					
				1→2 (IN→N.C.)		1→3 (IN→N.O.)		1→2 (IN→N.C.)			1→3 (IN→N.O.)		
		N.C.	N.O.	Av x 10 ⁻⁶ m ²	Cv converted	Av x 10 ⁻⁶ m ²	Cv converted	C [dm ³ /(s·bar)]	b	Cv	C [dm ³ /(s·bar)]	b	Cv
VDW200	M5 1/8 (6A)	1	1	0.72	0.03	0.96	0.04	0.12	0.35	0.03	0.13	0.52	0.04
		1.6		1.9	0.08			0.31	0.45	0.09			
VDW300	1/8 (6A) 1/4 (8A)	2	1.8	3.8	0.16	3.1	0.13	0.52	0.52	0.16	0.38	0.50	0.12
		3		6.7	0.28			1.0	0.52	0.30			
		4		11	0.44			1.5	0.49	0.46			

Series VDW200/300

Construction

VDW250

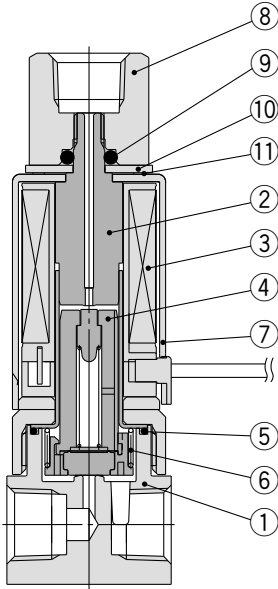

VDW350

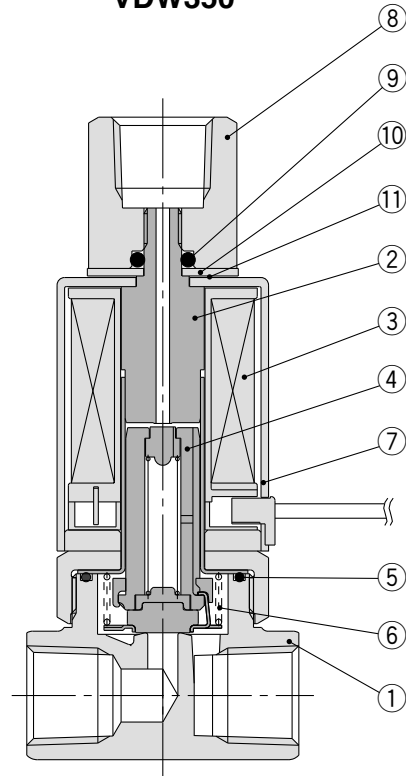

Component Parts

No.	Description	Material	
		Standard	Option
1	Body	Brass (C37)	Stainless steel
2	Tube assembly	Stainless steel	—
3	Coil assembly	—	—
4	Armature assembly	Stainless steel, PPS, NBR	Stainless steel, PPS, FKM, EPDM
5	O-ring (Body)	NBR	FKM, EPDM
6	Return spring	Stainless steel	—
7	Cover	Steel (SPCE)	—
8	Socket	Brass (C36)	Stainless steel
9	O-ring	NBR	FKM, EPDM
10	Plate	Steel (SPCC)	—
11	Wave washer	Stainless steel	—

**Compact Direct Operated
3 Port Solenoid Valve For Water and Air Series VDW200/300**

Dimensions

VDW250-□^G_W

VDW350-□^G_W

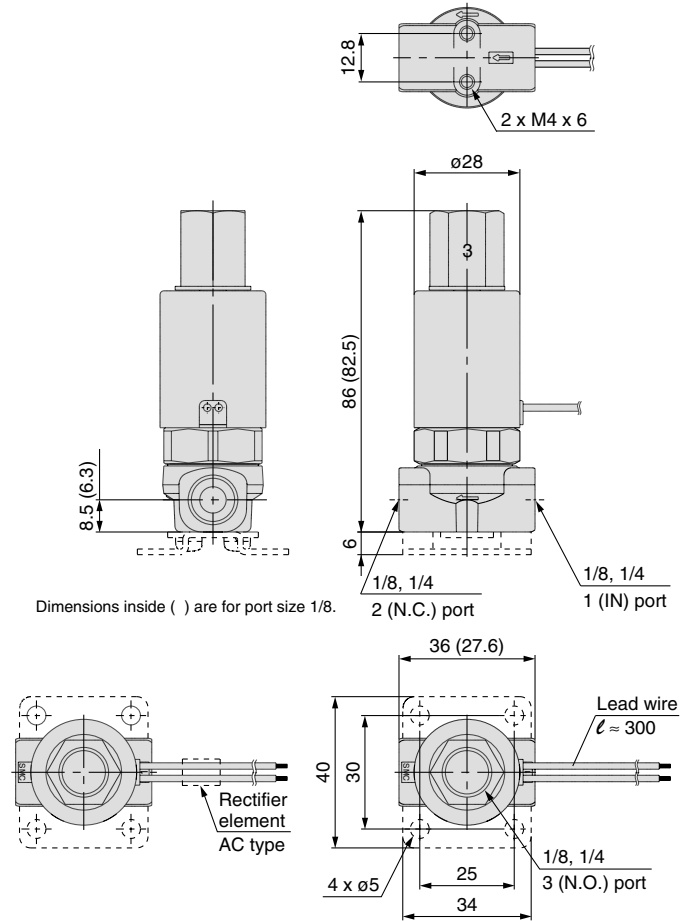
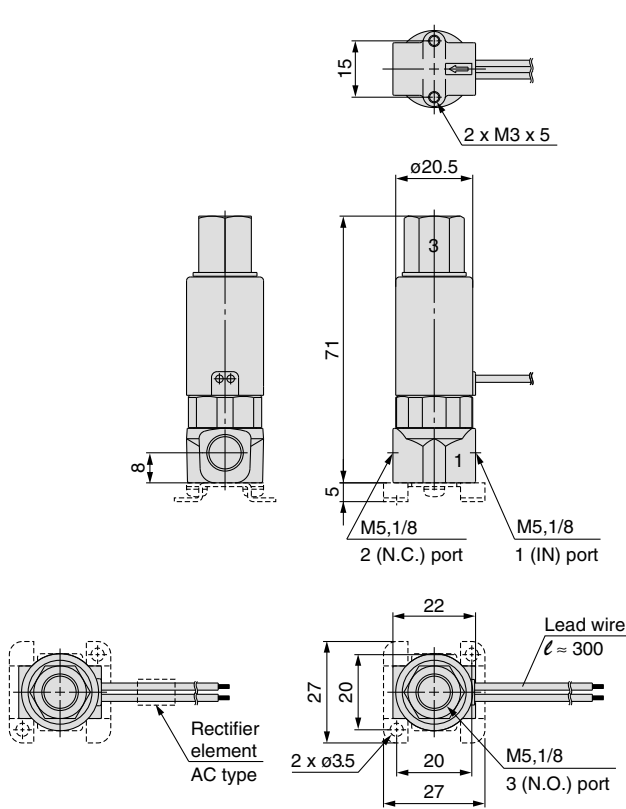

Bracket assembly part no.

- Series 200

VDW20-15A-1

- Series 300

VCW20-12-01A

Series VDW200/300

Dimensions

VDW250-□F

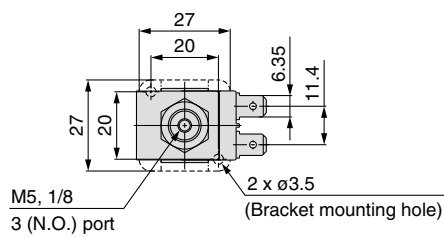

VDW350-□F

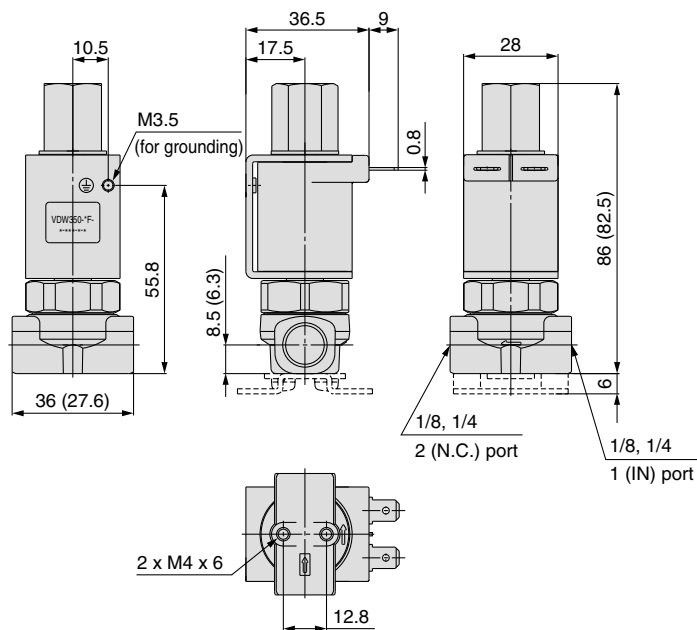
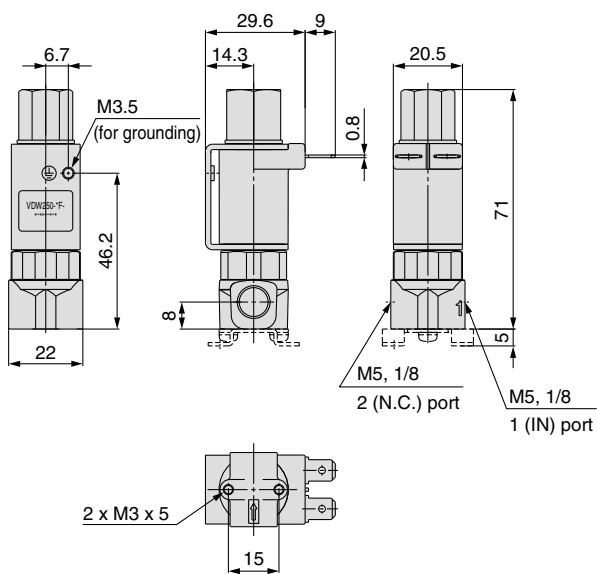
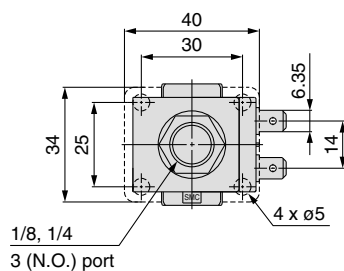

Bracket assembly part no.

- Series 200

VDW20-15A-1

- Series 300

VCW20-12-01A

Series VDW Made to Order

Please contact SMC for detailed dimensions, specifications and lead times.



1 Non-leak (10^{-6} Pa·m³/sec) /
Vacuum (0.1 Pa·abs) Specification **Symbol**
X22

VDW – X22

2 Oil-free Specification **Symbol**
X23

VDW – X23

3 Lead Wire Length: 600 mm
Specification **Symbol**
X60

VDW – X60

4 Seal Material: FFKM
Specification **Symbol**
X133

VDW – X133





Series VDW

Safety Instructions

These safety instructions are intended to prevent a hazardous situation and/or equipment damage. These instructions indicate the level of potential hazard by labels of "**Caution**", "**Warning**" or "**Danger**". To ensure safety, be sure to observe ISO 4411 ^{Note 1)}, JIS B 8370 ^{Note 2)} and other safety practices.

 **Caution** : Operator error could result in injury or equipment damage.

 **Warning** : Operator error could result in serious injury or loss of life.

 **Danger** : In extreme conditions, there is a possible result of serious injury or loss of life.

Note 1) ISO 4414: Pneumatic fluid power – General rules relating to systems

Note 2) JIS B 8370: General Rules for Pneumatic Equipment

Warning

1. The compatibility of the pneumatic equipment is the responsibility of the person who designs the pneumatic system or decides its specifications.

Since the products specified here are used in various operating conditions, their compatibility for the specific pneumatic system must be based on specifications or post analysis and/or tests to meet the specific requirements. The expected performance and safety assurance are the responsibility of the person who has determined the compatibility of the system. This person should continuously review the suitability of all items specified, referring to the latest catalog information with a view to giving due consideration to any possibility of equipment failure when configuring a system.

2. Only trained personnel should operate pneumatically operated machinery and equipment.

Fluids can be dangerous if handled incorrectly. Assembly, handling or repair of the systems using pneumatic equipment should be performed by trained and experienced operators.

3. Do not service machinery/equipment or attempt to remove components until safety is confirmed.

1. Inspection and maintenance of machinery/equipment should only be performed once measures to prevent falling or runaway of the driven objects have been confirmed.
2. When equipment is removed, confirm the safety process as mentioned above. Turn off the supply pressure for this equipment and exhaust all residual compressed air in the system.
3. Carefully restart the machinery, confirming that safety measures are being implemented.

4. Contact SMC if the product will be used in any of the following conditions:

1. Conditions and environments beyond the given specifications, or if product is used outdoors.
2. With fluids whose application causes concern due to the type of fluid or additives, etc.
3. An application which has the possibility of having negative effects on people and/or property, requiring special safety analysis.

■ Exemption from Liability

1. SMC, its officers and employees shall be exempted from liability for any loss or damage arising out of earthquakes or fire, action by a third person, accidents, customer error with or without intention, product misuse, and any other damages caused by abnormal operating conditions.
2. SMC, its officers and employees shall be exempted from liability for any direct or indirect loss or damage, including consequential loss or damage, loss of profits or loss of chance, claims, demands, proceedings, costs, expenses awards, judgments and any other liability whatsoever including legal costs and expenses, which may be suffered or incurred, whether in tort (including negligence), contract, breach of statutory duty, equity or otherwise.
3. SMC is exempted from liability for any damages caused by operations not contained in the catalogues and/or instruction manuals, and operations outside of the specification range.
4. SMC is exempted from liability for any loss or damage whatsoever caused by malfunctions of its products when combined with other devices or software.



Series VDW

2/3 Port Solenoid Valve for Fluid Control Precautions 1

Be sure to read this before handling.

Design

⚠ Warning

1. Cannot be used as an emergency shutoff valve, etc.

The valves presented in this catalog are not designed for safety applications such as an emergency shutoff valve. If the valves are used in this type of system, other reliable safety assurance measures should also be adopted.

2. Extended periods of continuous energisation

Please consult with SMC when using with energisation for long periods of time.

3. Liquid rings

In cases with a flowing liquid, provide a by-pass valve in the system to prevent the liquid from entering the liquid seal circuit.

4. This solenoid valve cannot be used for explosion proof applications.

5. Maintenance space

The installation should allow sufficient space for maintenance activities (removal of the valve, etc.).

Selection

⚠ Warning

1. Confirm the specifications.

Give careful consideration to the operating conditions such as the application, fluid and environment, and use within the operating ranges specified in this catalogue.

2. Fluid temperature

Please use within the operating fluid temperature range.

3. Fluid quality

In the case of water

The use of a fluid which contains foreign matter can cause malfunction and seal failure. These problems are due to wearing of the valve seat and armature, and sticking to the sliding parts of the armature, etc. Install a suitable filter (strainer) immediately upstream from the valve. In general, a mesh of about 80 to 100 is a guideline for the filter.

In the case of air

Please use ordinary compressed air where a filter of 40 μm or less is provided on the inlet side piping. (Except dry air)

⚠ Caution

1. Leakage voltage

Particularly when using a resistor in parallel with a switching element and using a C-R element (surge voltage suppressor) to protect the switching element, take note that leakage current will flow through the resistor, C-R element, etc., creating a possible danger that the valve may not turn off.

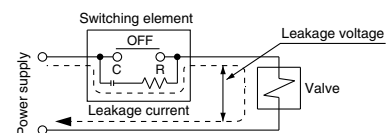

AC coil

10% or less of rated voltage

DC coil

2% or less of rated voltage

2. Low temperature operation

1. Valves can be used from an ambient temperature of -10°C , however, take measures to prevent solidification of impurities or freezing, etc.
2. When using valves for water applications in cold climates, firstly stop the water supply/discharge of the pump etc., and then take measures to prevent freezing, such as draining water from the piping. When heating by steam, be careful not to expose the coil portion to steam. Also, please take actions to prevent freezing such as heating the body.



Series VDW

2/3 Port Solenoid Valve for Fluid Control Precautions 2

Be sure to read this before handling.

Mounting

⚠ Warning

1. If air leakage increases or the equipment does not operate properly, stop operation.

After mounting is completed, confirm that it has been done correctly by performing a suitable function test.

2. Do not apply external forces to the coil section.

When tightening is performed, apply a wrench or other tool to the outside of the piping connection parts.

3. Do not warm the coil assembly with a heat insulator, etc.

Use tape, heaters, etc., to prevent freezing on the piping and body only. They can cause the coil to burn out.

4. Secure with brackets, except in the case of steel piping and copper fittings.

5. Avoid sources of vibration or adjust the arm from the body to the minimum length so that resonance will not occur.

6. Instruction manual

The product should be mounted and operated after the instruction manual is thoroughly read and its contents are understood. Keep the instruction manual where it can be referred to as needed.

7. Painting and coating

Warnings or specifications printed or labeled on the product should not be erased, removed or covered up.

Piping

⚠ Caution

1. Preparation before piping

Before piping is connected, it should be thoroughly blown out with air (flushing) or washed to remove chips, cutting oil and other debris from inside the pipe.

2. Wrapping of pipe tape

When connecting pipes, fittings, etc., be sure that chips from the pipe threads and sealing material do not enter the valve. Furthermore, when pipe tape is used, leave 1.5 to 2 thread ridges exposed at the end of the threads.

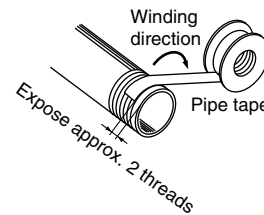

3. Avoid connecting ground lines to piping, as this may cause electric corrosion of the system.

4. Always tighten threads with the proper tightening torque.

When attaching fittings to valves, tighten with the proper tightening torque shown below.

Tightening Torque for Piping

Connection threads	Proper tightening torque N·m (kgf·cm)
M5	1.5 to 2 (15 to 20)
Rc 1/8	7 to 9 (70 to 90)
Rc 1/4	12 to 14 (120 to 140)
Rc 3/8	22 to 24 (220 to 240)

* Reference

Tightening of M5 fitting threads

After tightening by hand, tighten approximately 1/6 turn further with a tightening tool. However, when using miniature fittings, tighten an additional 1/4 turn after tightening by hand. (In cases where there are gaskets in two places, such as a universal elbow or universal tee, double the additional tightening to 1/2 turn.)

5. Connection of piping to products

When connecting piping to a product, refer to its instruction manual to avoid mistakes regarding the supply port, etc.



Series VDW

2/3 Port Solenoid Valve for Fluid Control Precautions 3

Be sure to read this before handling.

Wiring

⚠ Caution

1. As a rule, use electrical wire with a cross sectional area of 0.5 to 1.25 mm² for wiring.

Furthermore, do not allow excessive force to be applied to the lines.

2. Use electrical circuits which do not generate chattering in their contacts.
3. Use voltage which is within $\pm 10\%$ of the rated voltage.

When using a DC power supply where importance is placed on responsiveness, stay within $\pm 5\%$ of the rated value. The voltage drop is the value in the lead wire section connecting the coil.

Electrical Connections

⚠ Caution

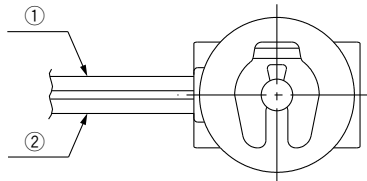

Rated voltage	Lead wire colour	
	①	②
DC	Black	Red
100 VAC	Blue	Blue
200 VAC	Red	Red
Other AC	Grey	Grey

* There is no polarity.

Electrical Circuit

⚠ Caution

DC circuit

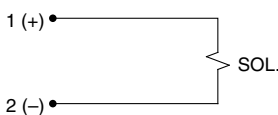

AC circuit

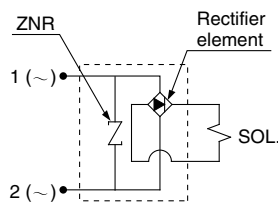

Operating Environment

⚠ Warning

1. Do not use the valves in an atmosphere having corrosive gases, chemicals, salt water, water, steam, or where there is direct contact with any of these.
2. Do not use in explosive atmospheres.
3. Do not use in locations subject to vibration or impact.
4. Do not use in locations where radiated heat will be received from nearby heat sources.
5. Employ suitable protective measures in locations where there is contact with water droplets, oil or welding spatter, etc.

Maintenance

⚠ Warning

1. Perform maintenance according to the procedure in the instruction manual.

Incorrect handling will cause damage or malfunction to devices or equipment.

2. Removing the product

1. Shut the fluid supply off and release the fluid pressure in the system.
2. Shut the power supply off.
3. Dismount the product.

3. Low frequency operation

Switch valves at least once every 30 days to prevent malfunction. Also, in order to use it under the optimum state, conduct a regular inspection every six months.

⚠ Caution

1. Filters and strainers

1. Be careful regarding clogging of filters and strainers.
2. Replace filter elements after one year of use, or earlier if the pressure drop reaches 0.1 MPa.
3. Clean strainers when the pressure drop reaches 0.1 MPa.
4. Exhaust the drain from an air filter periodically.

2. Storage

When not using for a long time (more than approx. one month) after use with water, thoroughly remove all moisture to prevent rust and deterioration of rubber materials, etc.



Series VDW Specific Product Precautions 1

Be sure to read this before handling.

Replacing the Solenoid Coils

Caution

2 port valve

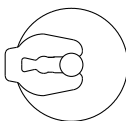
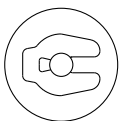
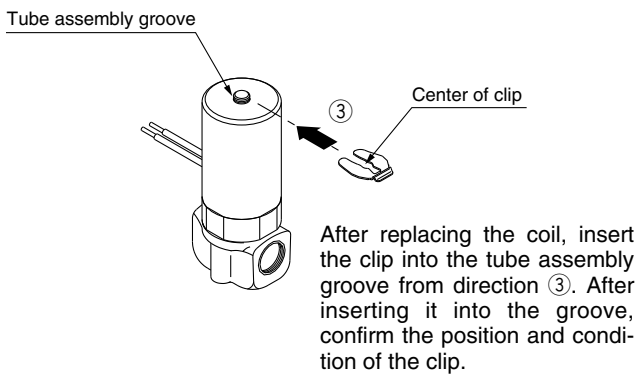
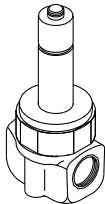
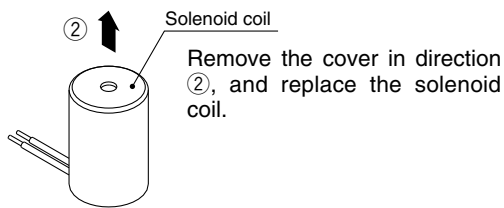
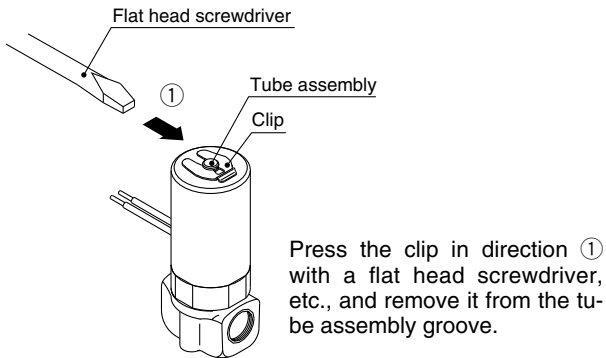

Inserted position

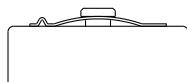

Inserted condition

3 port valve

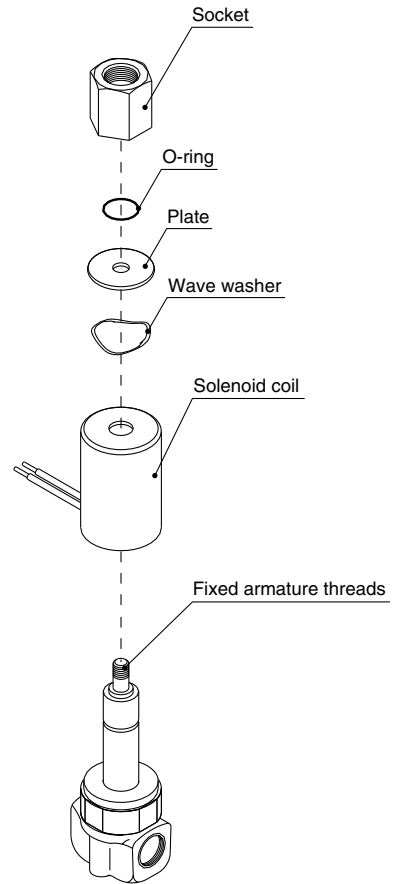

After removing the socket with a wrench, etc., lift the plate, wave washer and cover off, and replace the coil assembly. After replacing the coil, first tighten the socket by hand while holding down the plate and wave washer, and then tighten it further with a torque of 0.8 to 1 N·m.

*Precautions when attaching and removing the socket

- Be careful that the O-ring installed on the bottom (plate side) of the socket does not fall out or becomes chewed up, etc.
- Be sure to secure the body with a wrench, etc., and tighten the socket within the tightening torque range given above. If the torque is applied excessively, there is a danger of damaging the threads.



Series VDW Specific Product Precautions 2

Be sure to read this before handling.

Replacement Parts

• Solenoid coil part no.

VDW **2** 0-1 **C** **1** - **1** -

Series

1	10
2	20, 200
3	30, 300

Coil type

C	Grommet / Tape winding
F	Faston™ terminal / Molded
W	Grommet / Molded

Type

1	10, 20, 30
2	200, 300

• Lead wire length

-	300 mm
L1 (Note)	600 mm

Note) Type L1 is optional.

• Voltage

1	100 VAC
2	200 VAC
3	110 VAC
4	220 VAC
5	24 VDC
6	12 VDC
V	6 VDC
S	5 VDC
R	3 VDC

Series and Coil Type Combinations

Voltage	Grommet / Tape winding	Faston™ terminal / Molded	Grommet / Molded
100 VAC	●	—	●
200 VAC	●	—	●
110 VAC	●	—	●
220 VAC	●	—	●
24 VDC	●	●	●
12 VDC	●	●	●
6 VDC	●	●	●
5 VDC	●	●	●
3 VDC	●	●	●

Note) To have a label on the cover, enter the part number below together with the coil part number.

AZ-T-VDW Valve model no. on page 1/6/12

• Clip part no. (2 port)

VDW **2** 0-10

Series

2	10, 20
3	30

• Socket assembly part no. (3 port)

VDW **2** 0-12A-**01** -

Series

2	200
3	300

Port size

Symbol	Port size	Series	
		200	300
M5	M5	○	—
01	1/8 (6A)	○	○
02	1/4 (8A)	—	○

Material

Symbol	Socket material	Seal material
-	Brass (C37)	NBR
A		FKM
B		EPDM
G	Stainless steel	NBR
H		FKM
J		EPDM
L		FKM

• Thread type

-	Rc
F	G
N	NPT

Piping to 3 Port Valve N.O. Port

Caution

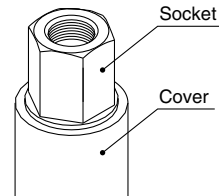

When piping to a N.O. port, be sure to perform piping work while securing the socket by using a wrench or other tool. Refer to back page 3 for other precautions related to piping.

Fluid Flow Direction

Caution

The maximum operating pressure differential differs depending on the flow direction of the fluid. If the pressure differential at each port exceeds the values in the table below, valve leakage may occur.

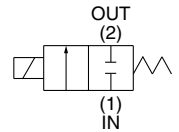

2 Port Valve

Model	Orifice size (mm ø)	Max. operating pressure differential (MPa)	
		Pressure port 1	Pressure port 2 (Note)
VDW10	1	0.9	0.4
	1.6	0.4	0.2
VDW20	1.6	0.7	0.2
	3.2	0.2	0.05
VDW30	2	0.8	0.2
	3	0.4	0.1
	4	0.2	0.05

Note) When applying pressure to port 2, be careful to avoid vibration and impacts, etc.

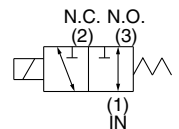

3 Port Valve

Model	Orifice size (mm ø)	Max. operating pressure differential (MPa)	
		Pressure port 1	Pressure port 2, 3 (Note 1)
VDW200	1	0.9	0.3
	1.6	0.7	0.1
VDW300	2	0.8	0.2
	3	0.4	0.1
	4	0.2	0.05

Note 1) Indicates the maximum operating pressure differential between ports 2 and 3. Note 2) When the port 2 pressure is in the higher pressure side, be careful to avoid vibration and impacts, etc.



Series VDW Specific Product Precautions 3

Be sure to read this before handling.

Glossary

Pressure

1. Maximum operating pressure differential

This indicates the maximum pressure differential (inlet and outlet pressure differential) which can be allowed for operation with the valve closed or open. When the outlet pressure is 0 MPa, this becomes the maximum operating pressure.

2. Maximum operating pressure

This indicates the limit of pressure that can be applied inside the pipelines. (Line pressure)
(The pressure differential of a solenoid valve unit must be no more than the maximum operating pressure differential.)

3. Withstand pressure

The pressure which must be withstood without a drop in performance after returning to the operating pressure range (The value under the prescribed conditions).

Electricity

1. Surge voltage

A high voltage which is momentarily generated in the shut-off unit by shutting off the power.

Other

1. Material

NBR: Nitrile rubber
FKM: Fluoro rubber = FPM — Trade name: Viton®, DAI-EL™, etc.
C37: Brass
EPDM: Ethylene propylene rubber = EPR

Faston™ Terminals

1. Faston™ is a trademark of Tyco Electronics Corp.
2. For electrical connection of the Faston™ terminal and molded coil, please use Tyco's "Amp/Faston™ connector/250 Series" or the equivalent.
3. When providing a body ground, please use the frame ground (M3.5).

(Recommended fastening bolt: M3.5, length 5 mm)

Record of changes

B edition * Addition of molded coil specifications to the VDW10/20/30 series and the VDW200/300 series.

KZ



EUROPEAN SUBSIDIARIES:



Austria

SMC Pneumatik GmbH (Austria).
Girakstrasse 8, A-2100 Korneuburg
Phone: +43 2262-62280, Fax: +43 2262-62285
E-mail: office@smc.at
http://www.smc.at



France

SMC Pneumatique, S.A.
1, Boulevard de Strasbourg, Parc Gustave Eiffel
Bussy Saint Georges F-77607 Marne La Vallée Cedex 3
Phone: +33 (0)1-6476 1000, Fax: +33 (0)1-6476 1010
E-mail: contact@smc-france.fr
http://www.smc-france.fr



Netherlands

SMC Pneumatics BV
De Ruyterkade 120, NL-1011 AB Amsterdam
Phone: +31 (0)20-5318888, Fax: +31 (0)20-5318880
E-mail: info@smcpneumatics.nl
http://www.smcpneumatics.nl



Spain

SMC España, S.A.
Euzazobidea 14, 01015 Vitoria
Phone: +34 945-184 100, Fax: +34 945-184 124
E-mail: post@smc.smces.es
http://www.smces.es



Belgium

SMC Pneumatics N.V./S.A.
Nijverheidsstraat 20, B-2160 Wommelgem
Phone: +32 (0)3-355-1464, Fax: +32 (0)3-355-1466
E-mail: post@smcpneumatics.be
http://www.smcpneumatics.be



Germany

SMC Pneumatik GmbH
Boschring 13-15, D-63329 Egelsbach
Phone: +49 (0)6103-4020, Fax: +49 (0)6103-402139
E-mail: info@smc-pneumatik.de
http://www.smc-pneumatik.de



Norway

SMC Pneumatics Norway A/S
Vollsvæien 13 C, Granfos Næringspark N-1366 Lysaker
Tel: +47 67 12 90 20, Fax: +47 67 12 90 21
E-mail: post@smc-norge.no
http://www.smc-norge.no



Sweden

SMC Pneumatics Sweden AB
Ekhagsvägen 29-31, S-141 71 Huddinge
Phone: +46 (0)8-603 12 00, Fax: +46 (0)8-603 12 90
E-mail: post@smcpneumatics.se
http://www.smc.nu



Bulgaria

SMC Industrial Automation Bulgaria EOOD
16 Kliment Ohridski Blvd., fl.13 BG-1756 Sofia
Phone: +359 2 9744492, Fax: +359 2 9744519
E-mail: office@smc.bg
http://www.smc.bg



Greece

SMC Hellas EPE
Anagenniseos 7-9 - P.C. 14342, N. Philadelphia, Athens
Phone: +30-210-2717265, Fax: +30-210-2717766
E-mail: sales@smchellas.gr
http://www.smchellas.gr



Poland

SMC Industrial Automation Polska Sp.z.o.o.
ul. Poloneza 89, PL-02-826 Warszawa,
Phone: +48 22 211 9600, Fax: +48 22 211 9617
E-mail: office@smc.pl
http://www.smc.pl



Switzerland

SMC Pneumatik AG
Dorfstrasse 7, CH-8484 Weisslingen
Phone: +41 (0)52-396-3131, Fax: +41 (0)52-396-3191
E-mail: info@smc.ch
http://www.smc.ch



Croatia

SMC Industrijska automatika d.o.o.
Cromerec 12, 10000 ZAGREB
Phone: +385 1 377 66 74, Fax: +385 1 377 66 74
E-mail: office@smc.hr
http://www.smc.hr



Hungary

SMC Hungary Ipari Automatizálási Kft.
Budafoki út 107-113, H-1117 Budapest
Phone: +36 1 371 1343, Fax: +36 1 371 1344
E-mail: office@smc.hu
http://www.smc.hu



Portugal

SMC Sucursal Portugal, S.A.
Rua de Eng^o Ferreira Dias 452, 4100-246 Porto
Phone: +351 22-610-89-22, Fax: +351 22-610-89-36
E-mail: postpt@smc.smces.es
http://www.smces.es



Turkey

Entek Pnömatik San. ve Tic Ltd. Sti.
Perpa Tic. Merkezi Kat: 11 No: 1625, TR-80270 Okmeydanı Istanbul
Phone: +90 (0)212-221-1512, Fax: +90 (0)212-221-1519
E-mail: smc-entek@entek.com.tr
http://www.entek.com.tr



Czech Republic

SMC Industrial Automation CZ s.r.o.
Hudcova 78a, CZ-61200 Brno
Phone: +420 5 414 24611, Fax: +420 5 412 18034
E-mail: office@smc.cz
http://www.smc.cz



Ireland

SMC Pneumatics (Ireland) Ltd.
2002 Citywest Business Campus, Naas Road, Saggart, Co. Dublin
Phone: +353 (0)1-403 9000, Fax: +353 (0)1-464-0500
E-mail: sales@smcpneumatics.ie
http://www.smcpneumatics.ie



Romania

SMC Romania srl
Str Funzei 29, Sector 2, Bucharest
Phone: +40 213205111, Fax: +40 213261489
E-mail: smcromania@smcromania.ro
http://www.smcromania.ro



UK

SMC Pneumatics (UK) Ltd
Vincent Avenue, Crownhill, Milton Keynes, MK8 0AN
Phone: +44 (0)900 1382930 Fax: +44 (0)1908-555064
E-mail: sales@smcpneumatics.co.uk
http://www.smcpneumatics.co.uk



Denmark

SMC Pneumatik A/S
Knudsminde 4B, DK-8300 Odder
Phone: +45 70252900, Fax: +45 70252901
E-mail: smc@smc-pneumatik.dk
http://www.smdk.com



Italy

SMC Italia S.p.A
Via Garibaldi 62, I-20061 Carugate, (Milano)
Phone: +39 (0)2-92711, Fax: +39 (0)2-9271365
E-mail: mailbox@smcitalia.it
http://www.smcitalia.it



Russia

SMC Pneumatik LLC.
4B Sverdlovskaja nab, St. Petersburg 195009
Phone: +7 812 718 5445, Fax: +7 812 718 5449
E-mail: info@smc-pneumatik.ru
http://www.smc-pneumatik.ru



Estonia

SMC Pneumatics Estonia OÜ
Laki 12, 106 21 Tallinn
Phone: +372 6510370, Fax: +372 65110371
E-mail: smc@smcpneumatics.ee
http://www.smcpneumatics.ee



Latvia

SMC Pneumatics Latvia SIA
Smerla 1-705, Riga LV-1006
Phone: +371 781-77-00, Fax: +371 781-77-01
E-mail: info@smclv.lv
http://www.smclv.lv



Slovakia

SMC Priemyselná Automatizácia, s.r.o.
Námestie Matina Benku 10, SK-81107 Bratislava
Phone: +421 2 444 56725, Fax: +421 2 444 56028
E-mail: office@smc.sk
http://www.smc.sk



Finland

SMC Pneumatics Finland Oy
PL72, Tiistintintintie 4, SF-02231 ESPOO
Phone: +358 207 513513, Fax: +358 207 513595
E-mail: smcfi@smc.fi
http://www.smc.fi



Lithuania

SMC Pneumatics Lietuva, UAB
Oslo g.1, LT-04123 Vilnius
Phone: +370 5 264 81 26, Fax: +370 5 264 81 26



Slovenia

SMC Industrijska Avtomatika d.o.o.
Mirnska cesta 7, SLO-8210 Trebnje
Phone: +386 7 3885412 Fax: +386 7 3885435
E-mail: office@smc.si
http://www.smc.si



OTHER SUBSIDIARIES WORLDWIDE:

ARGENTINA, AUSTRALIA, BOLIVIA, BRASIL, CANADA, CHILE,
CHINA, HONG KONG, INDIA, INDONESIA, MALAYSIA, MEXICO,
NEW ZEALAND, PHILIPPINES, SINGAPORE, SOUTH KOREA,
TAIWAN, THAILAND, USA, VENEZUELA

<http://www.smceu.com>
<http://www.smcworld.com>