

High Accuracy, Wedge Cam - MHK MHK2-25DF

Datasheet

General series information

- Maximum gripping force per finger 86 N at 0.5 MPa
- Double acting
- Repeatability: ± 0.01 mm
- Max. operating frequency: 120 c.p.m.

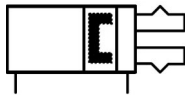

Gripper, internal grip, double-acting with permanent magnet on piston

Standard specifications

Finger Stroke	Standard
Bore Size	25 mm
Action	D (Double Acting)
Finger Material	Carbon Steel
Dust Cover	F [Fluoro Rubber (FKM)]
Auto Switch	No Switch
Lead Wire or Prewired Connector	0.5m (Or None in the Case of No Switch)
Number	2 pcs. (Or None in the Case of No Switch)
Maximum operating pressure	0.6 MPa
Minimum operating pressure	0.1 MPa
Maximum ambient temperature	60 °C
Minimum ambient temperature	-10 °C
Repeatability	± 0.01 mm
Lubrication	Not required
Effective holding force per finger, external (0.5 MPa)	80 N
Effective holding force per finger, internal (0.5 MPa)	86 N
Opening / closing stroke (both sides)	14 mm
Fluid	Air
Max. operating frequency	120 c.p.m

Weight

0.446 Kg

Dimensions

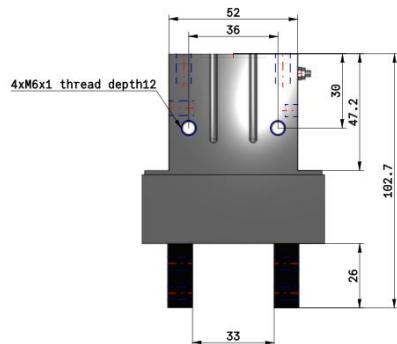
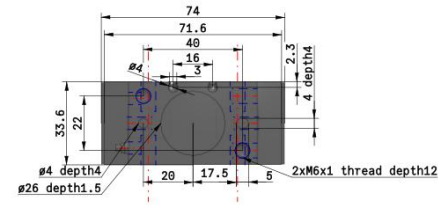
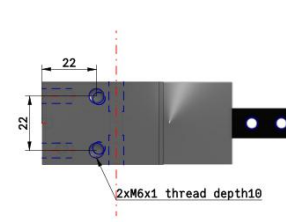
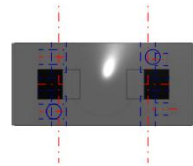
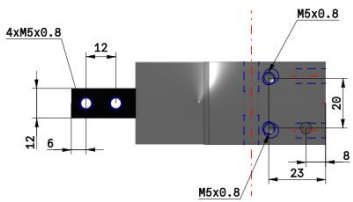
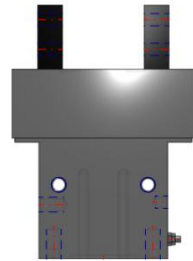

Constructions

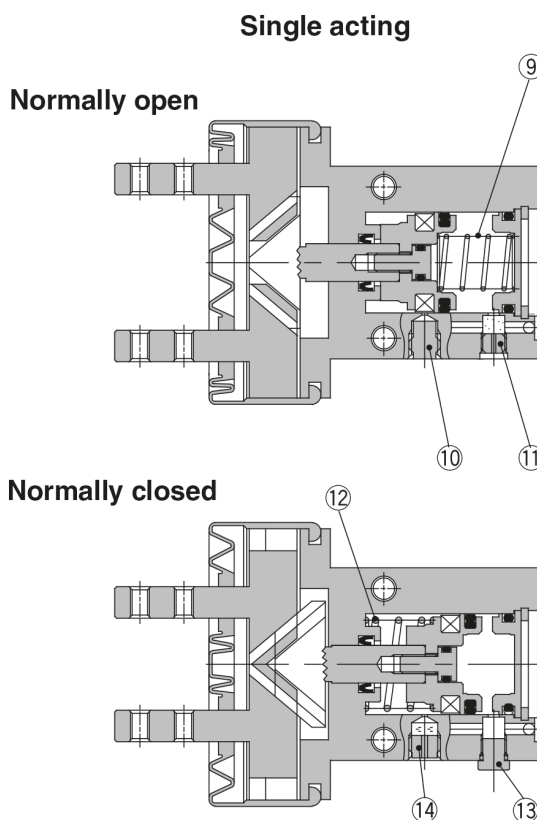
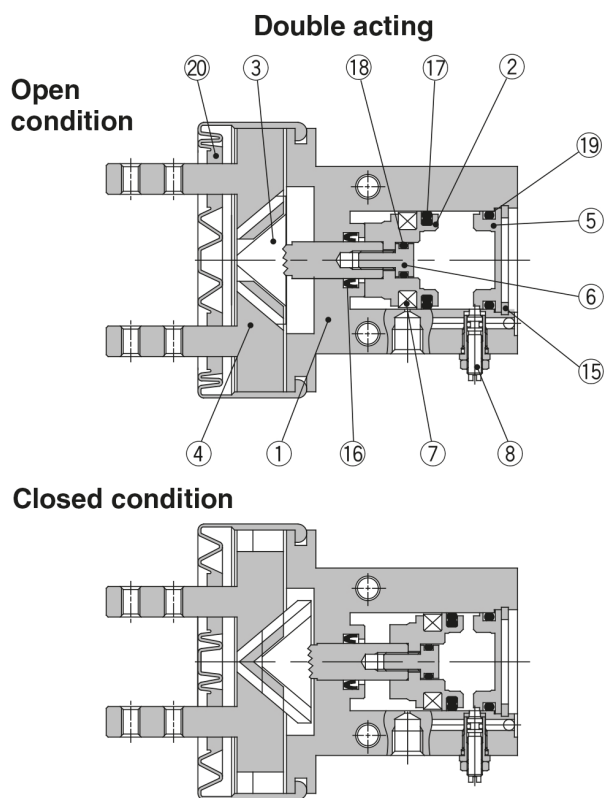

Component Parts

No.	Description	Material	Note
1	Body	Aluminium alloy	Hard anodised
2	Piston	Aluminium alloy	Hard anodised
3	Cam	Carbon steel	Heat treated, Specially treated
4	Finger	Carbon steel	Heat treated, Specially treated
		Stainless steel 304	Option
5	Cap	Aluminium alloy	Hard anodised
6	Piston bolt	Stainless steel	
7	Rubber magnet	Synthetic rubber	

No.	Description	Material	Note
8	Needle assembly		
9	N.O. spring	Piano wire	
10	Plug	Brass	Electroless nickel plated
11	Exhaust plug	Brass	Electroless nickel plated
12	N.C. spring	Piano wire	
13	Plug assembly	Brass	Electroless nickel plated
14	Exhaust plug A	Brass	Electroless nickel plated
15	Type C retaining ring	Carbon steel	Nickel plated

Additional information

Catalogue

[MHK2_EU.pdf](#)

Operation manuals

[OM_MHK2_OMF0058EN.pdf](#)