

## Standard – ASP ASP330F-01-06S

### Datasheet

### General series information

- Port Size: 1/8, 1/4, 3/8, 1/2
- Applicable Tubing O.D.: Ø 6 to Ø 12 mm and Ø 1/4" to Ø 1/2"
- Operating Pressure Range: 0.1 to 1 MPa.

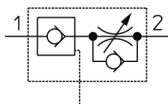

Speed controller with pilot check valve

### Standard specifications

Body Size	3 (1/8 Basis)
Port Size	01 (Cylinder Side [R[PT] 1/8] Pilot Port [M5X0.8])
Applicable Tube OD	Ø6
Made to Order	None
Lock Nut	Standard (Hexagon)
Pressure medium	Compressed Air
Maximum temperature of pressure medium	60 °C
Minimum temperature of pressure medium	-5 °C
Maximum operating pressure	1 MPa
Minimum operating pressure	0.1 MPa
Proof pressure	1.5 MPa
Maximum ambient temperature	60 °C
Minimum ambient temperature	-5 °C
Function of Flow control valve	Meter-out
Flow rate	180 l/min
Pilot check valve actuation pressure	50 % or more of operating pressure
Number of needle revolutions	10
Weight	0.032 Kg

## Dimensions

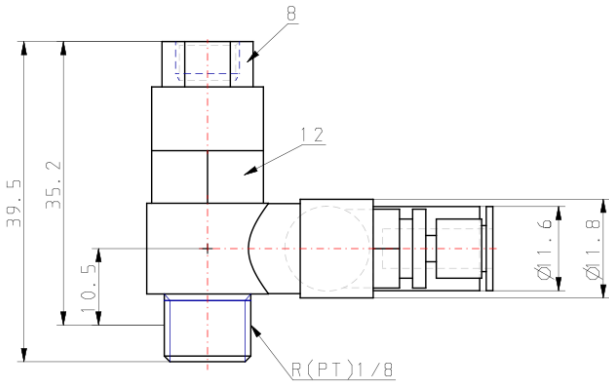
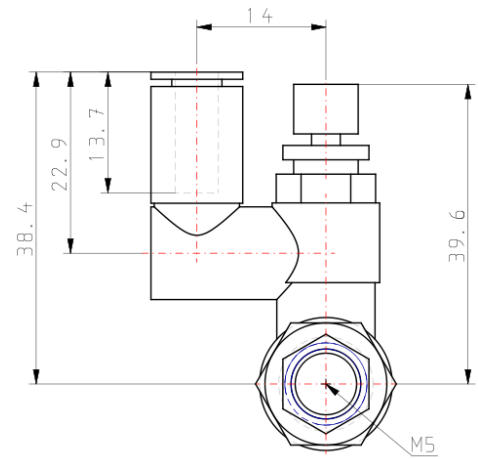
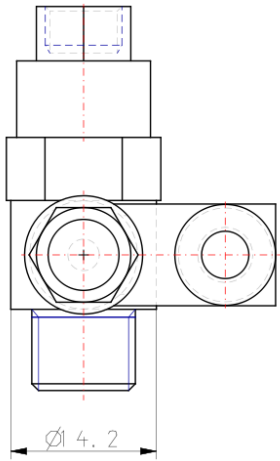

## Constructions

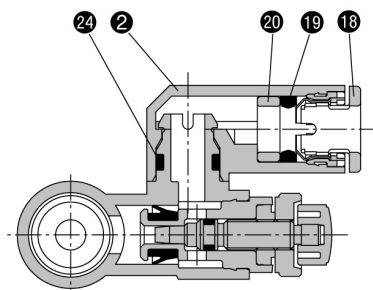
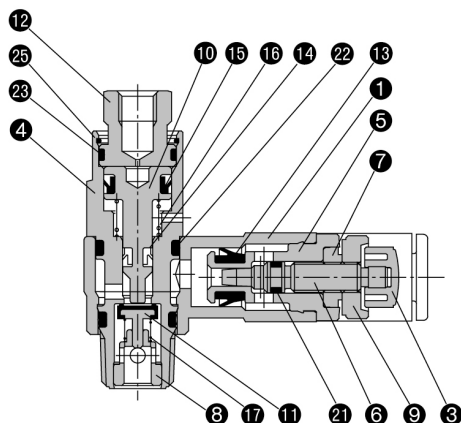

### Parts list

No.	Description	Material	Note
1	Body A	PBT	
2	Elbow body	PBT	
3	Knob	PBT	
4	Pilot body	Brass	Electroless nickel plated
5	Body B	Brass	Electroless nickel plated
6	Needle	Brass	Electroless nickel plated
7	Needle guide	Brass	Electroless nickel plated
8	Guide	Brass	Electroless nickel plated
9	Lock nut	Brass	Electroless nickel plated
10	Piston	Brass	Electroless nickel plated
11	Valve	Stainless steel, NBR	
12	Cover	Brass	Black zinc chromated
13	U seal	NBR	

### Parts list

No.	Description	Material	Note
14	DY seal	PBT	
15	DY seal	PBT	
16	Spring	Stainless steel	
17	Spring	Stainless steel	
18	Cassette	POM, Stainless steel <sup>Note 1)</sup>	
19	Seal	NBR	
20	Spacer	POM <sup>Note 2)</sup>	
21	O-ring	NBR	
22	O-ring	NBR	
23	O-ring	NBR	
24	O-ring	NBR	
25	Ring	Stainless steel	

Note 1)  $\phi 10$ ,  $\phi 12$ ,  $\phi 3/8"$ ,  $\phi 1/2"$  are POM, stainless steel and brass (electroless nickel plated).  
 Note 2)  $\phi 1/4"$ ,  $\phi 3/8"$ ,  $\phi 1/2"$  are brass (electroless nickel plated).

## Additional information

Catalogue

[ASP-A\\_EU.pdf](#)

Installation manuals

[IM\\_ASP\\_TF222-097EN-A.pdf](#)