

ARM11B, Regulator Block, Individual Supply Type

ARM11BB2-R08-A

Datasheet

General series information

- Regulator block, individual supply type
- IN/OUT fittings: straight & elbow (metric & inch)
- IN/OUT piping: bottom, top
- Handle position: top, bottom, front
- Accessories: pressure gauge
- Options: 0.35MPa setting, non-relieving, oil free

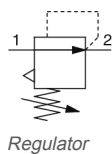

Standard specifications

Handle Position	B (Front)
Piping	2 (IN/OUT: Top)
Fitting	08 (IN: Straight Ø6, OUT: Straight Ø6)
Accessory	A (Pressure Gauge)
Option	None
Unit	Name Plate, Pressure Gauge MPa
Digital Pressure Switch Output Specifications	None
Maximum temperature of pressure medium	60 °C
Minimum temperature of pressure medium	-5 °C (with no freezing)
Maximum operating pressure	1.0 MPa
Proof pressure	1.5 MPa
Set pressure range	0.05 - 0.7 MPa
Applicable fluid	Air
Regulator construction	Direct acting
Working principle	Piston type
Relief mechanism	Relieving type
Weight	0.330 Kg

Dimensions

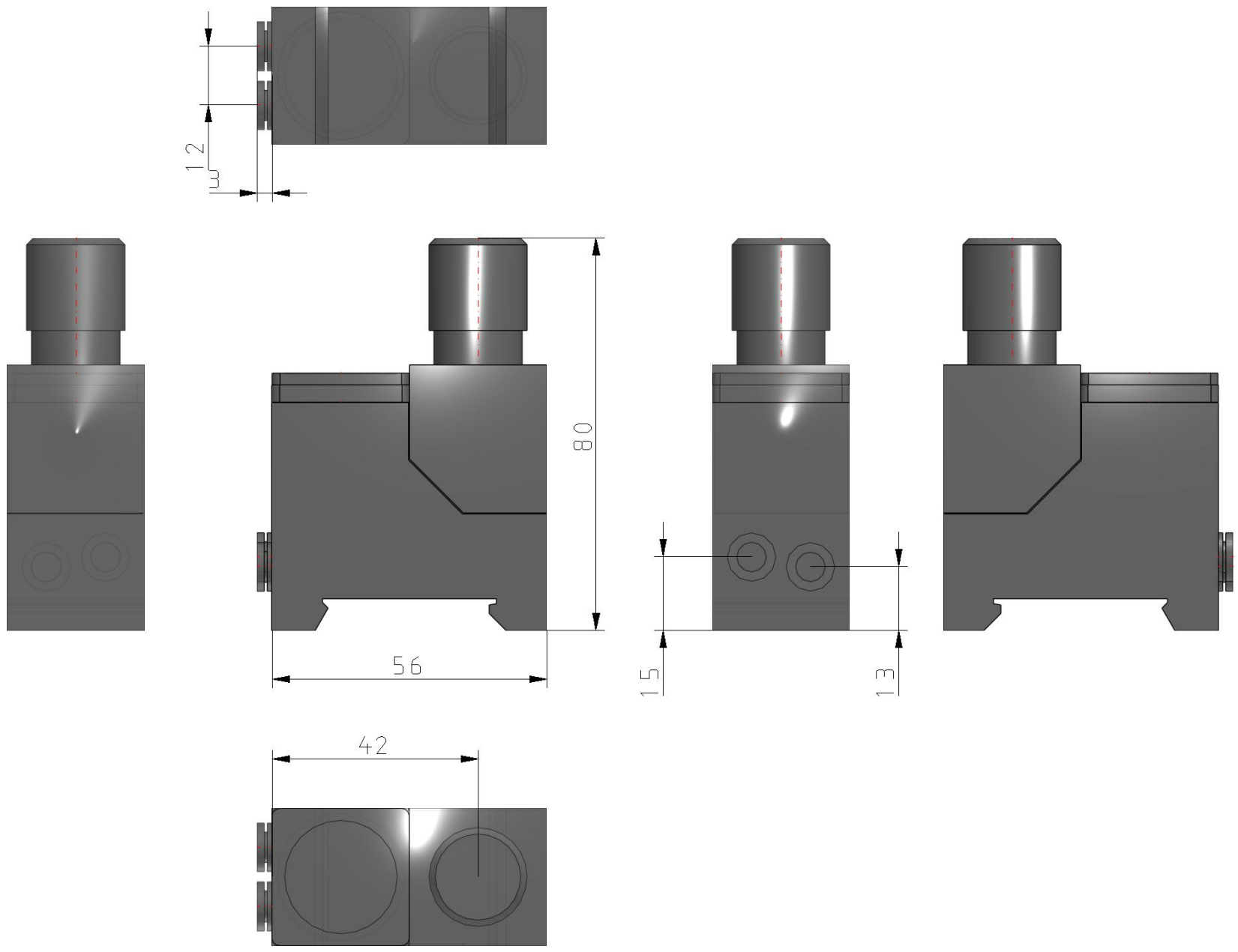

Specifications are subject to change without prior notice and any obligation on the part of the manufacturer.

Additional information

Catalogue	ARM10-11_EU.pdf
Operation manuals	arm10_11_op_man_ar_-omg0039-a.pdf