

Standard - MHC2 MHC2-20S

Datasheet

General series information

- Maximum gripping moment 1.36 Nm at 0.5 MPa
- Opening angle from 30° to -10°
- Double acting
- Repeatability: ± 0.01 mm
- Max. operating frequency: 180 c.p.m.



Gripper, normally open, single-acting with permanent magnet on piston

Standard specifications

Bore Size	20mm
Action	S (Single Acting N.O.)
Auto Switch	No Switch
Lead Wire or Prewired Connector	0.5m (Or None in the Case of No Switch)
Number	2 pcs. (Or None in the Case of No Switch)
Maximum operating pressure	0.6 MPa
Minimum operating pressure	0.25 MPa
Maximum ambient temperature	60 °C
Minimum ambient temperature	-10 °C
Conform to the European RoHS Directive	Conform
F124- Max-operating-frequency	180 c.p.m.
Repeatability	± 0.01 mm
Applicable fluid	Air
Lubrication	Non Lube
Opening / closing stroke (both sides)	30° to -10 °
Holding moment (effective value)	0.54 N.m
Weight	0.183 Kg

Dimensions

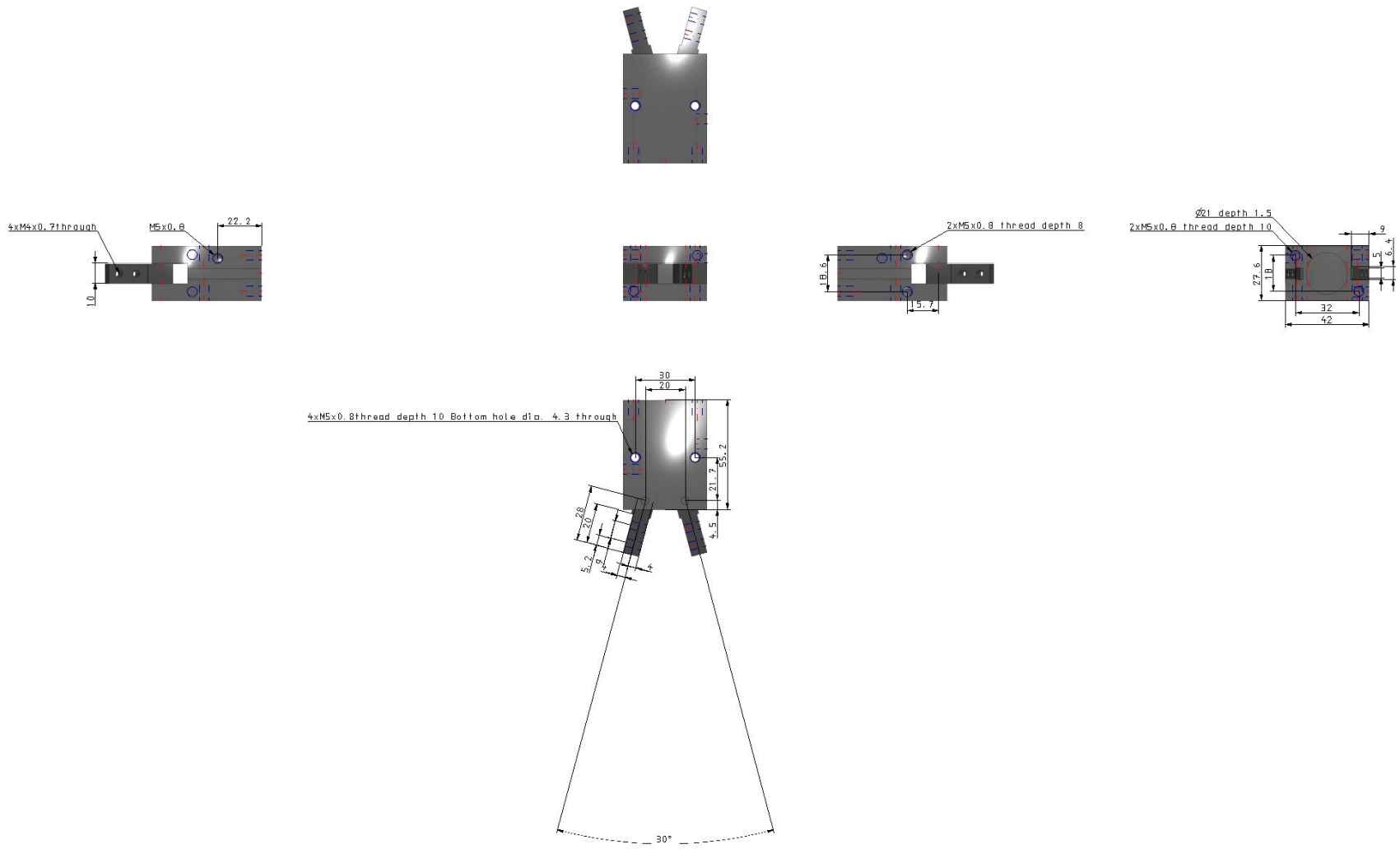

Constructions

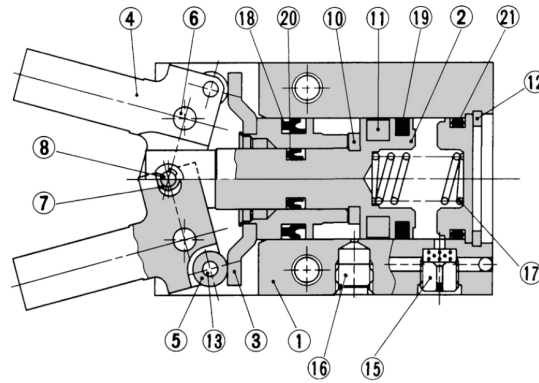

Component Parts

No.	Description	Material	Note
1	Body	Aluminum alloy	Hard anodized
2	Piston A	Aluminum alloy	Hard anodized
3	Piston B assembly		
4	Finger	Carbon steel	Heat treated
5	Side roller	Carbon steel	Nitriding
6	Lever shaft	Stainless steel	Nitriding
7	Center roller	Carbon steel	Nitriding
8	Center pin	Carbon steel	Nitriding
9	Cap	Resin	
10	Bumper	Urethane rubber	
11	Rubber magnet	Synthetic rubber	

Component Parts

No.	Description	Material	Note
12	Type C retaining ring	Carbon steel	Phosphate coated
13	Needle roller	High carbon chrome bearing steel	
14	Needle assembly	Brass	Electroless nickel plated
15	Exhaust plug	Brass	Electroless nickel plated
16	Plug	Brass	Electroless nickel plated
17	Spring	Stainless steel spring wire	
18	Piston seal	NBR	
19	Piston seal	NBR	
20	Piston seal	NBR	
21	Gasket	NBR	

Additional information

Catalogue

[MHC_EU.pdf](#)

Operation manuals

[OM_MHC2_OMG0120EN.pdf](#)

[OM_MHC2_OMG0048EN.pdf](#)