

Compact Direct Operated 2/3-Port Solenoid Valve for Chemical Liquids



Low Particle Generation

Oil-free

Metal-free

* Fluid contact parts

Isolated structure

Direct operated rocker type/poppet type

The solenoid drive body is separated from the fluid area by a diaphragm.

Power consumption

(With power saving circuit)

1.0*1 W or less

*1 Refer to page 1.

Change in volume

(Pumping volume)

0.01 μ L or less



New Variations/Options

7 mm width
LVM07 Series

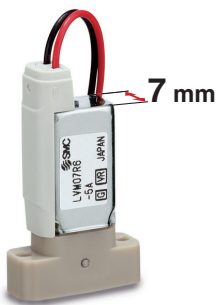

Body ported
LVM09 Series



Plug connector, With light/surge
voltage suppressor

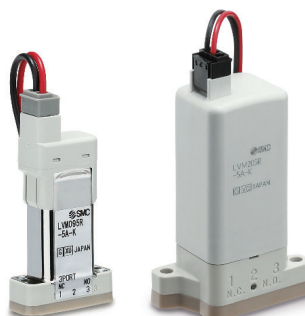

Plug connector



Light



With reverse
mounting prevention
pin



LVM Series



CAT.EUS70-30C-UK

Direct Operated Rocker Type

LVM07, 09/090, 10/100, 15/150, 20/200
 p. 7 p. 11 p. 17 p. 24 p. 29

Isolated structure

The solenoid drive body is separated from the fluid area by a diaphragm.

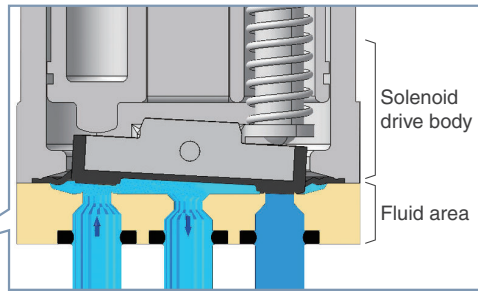

Fluid contact material (Metal-free)

Body/Plate

PEEK

Diaphragm

Choice of EPDM, FKM, or Kalrez®

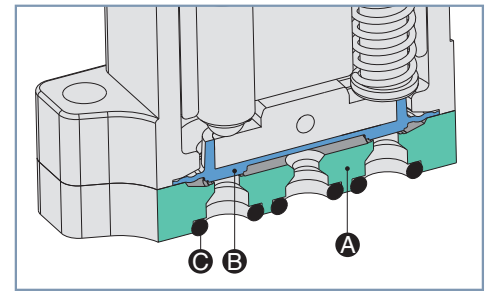

- A** Body/Plate material*1: PEEK
- B** Diaphragm material: EPDM, FKM, or Kalrez®
- C** Interface gasket/O-ring material: EPDM, FKM, or Kalrez®

*1 PFA can be selected for the plate material of the LVM10/100 base-mounted type.

* Kalrez® is a registered trademark of E. I. du Pont de Nemours and Company or its affiliates.

Change in volume (Pumping volume)

0.01 μL or less

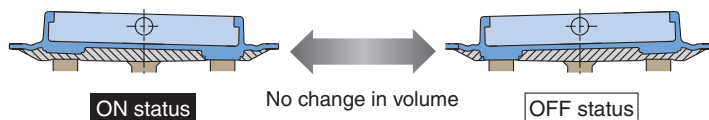

With a normal diaphragm valve, because the valve chamber volume varies depending on the ON or OFF status, the difference in volume is discharged into the outlet side of the valve when the valve is switched from ON to OFF.

However, with a rocker type valve, there is almost no change in volume, and thus **no fluid is discharged into the outlet side of the valve.**

Valve chamber volume

Residual liquid is reduced by suppressing the valve chamber volume.

Model	New LVM07	LVM09/090	LVM10/100	LVM15/150	LVM20/200
Valve chamber volume [μL]	8	18 (29)*1	20 (28)*1	50 (60)*1	84
Orifice diameter [mm]	0.8	1 (1.1)*2	1.4	1.6	2

*1 (): For R6

*2 (): For the base-mounted type

A type with a power saving circuit can be selected.

- Holding power consumption can be reduced substantially.
- Continuous energization for extended periods of time is possible.

Model		New LVM07	LVM09/090	LVM10/100	LVM15/150	LVM20/200
Power consumption [W]	Inrush	2.8	3.3	2.5	5.5	4
	Holding	0.8	0.9	1	1	0.6

Refer to 10 in "Design / Selection" on page 41 if the valve is to be energized continuously for extended periods of time or used with a manifold.

Space saving

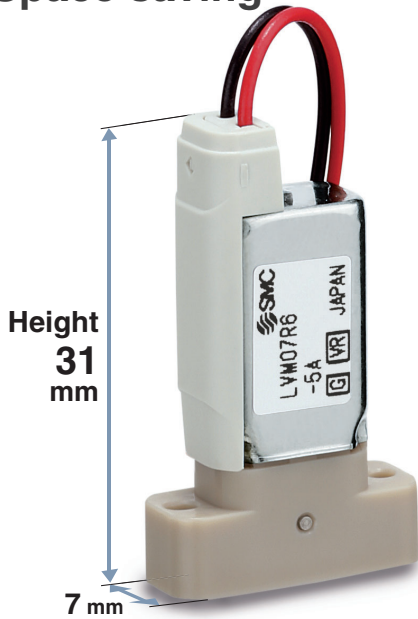

New LVM07 Series

- Valve width: 7 mm
- Compact & Lightweight
 - Volume: 3.9 cm³
 - Height: 31 mm
 - Weight: 7 g

Unit: mm

Model	Valve width	Manifold pitch
New LVM07	7	8
LVM09/090	9.5	10.5
LVM10/100	13	14
LVM15/150	16	17
LVM20/200	20	21

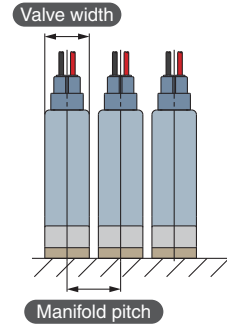

Required space reduced by 50 %

Reduction in piping volume. Manifold can be designed to suit the space

Weight reduced by 70 %

Weight reduced by using resin material

No piping work required

No piping work required between components

Composite Manifold (Made to order)

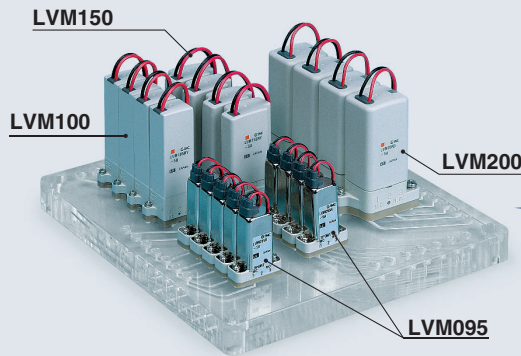

Flow passage style with high flexibility

Three-dimensional flow passage that cannot be created by machining or injection molding

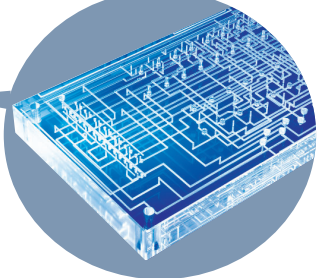

New Options

Plug connector, With light/surge voltage suppressor

Applicable models

Model	LVM07	LVM09/090	LVM10/100	LVM15/150	LVM20/200
Plug connector	—	●	●	●	●
With light/surge voltage suppressor	—	●	●	●	●

With reverse mounting prevention pin





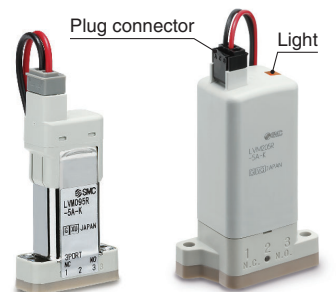



Applicable models

LVM07	LVM09/090	LVM10/100	LVM15/150	LVM20/200
●	●	●	●	●













Direct Operated Rocker Type

Series Variations

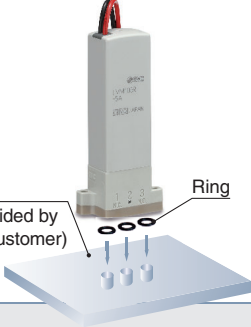
	Model	Valve type			Operating pressure range	Orifice dia. [mm]	Volume of valve chamber [μ L]	Valve width [mm]	Weight [g]	Power consumption [W]	Options			
		N.C. (2-port)	N.O. (2-port)	Universal (3-port)							Reverse mounting prevention pin	Electrical entry		With light/surge voltage suppressor
Base mounted 	New LVM07R6	●			-75 kPa to 0.1 MPa	0.8	8	7	7	Holding: 0.8 (With power saving circuit)	●	●	—	—
Body ported 	New LVM09R1	●			-75 kPa to 0.2 MPa	1	18	9.5	22	Standard: 2 Power saving option Holding: 0.9 (With power saving circuit)	—	●	●	●
	New LVM09R2		●											
	New LVM092R			●										
Base mounted 	LVM09R3	●			-75 kPa to 0.2 MPa	1.1	18	9.5	20	Standard: 2 Power saving option Holding: 0.9 (With power saving circuit)	●	●	●	●
	LVM09R4		●											
	New LVM09R6	●												
	LVM095R			●										
Body ported 	LVM10R1	●			-75 kPa to 0.25 MPa	1.4	20	13	34	Standard: 1.5 Power saving option Holding: 1 (With power saving circuit)	—	●	●	●
	LVM10R2		●											
	LVM102R			●										
Base mounted 	LVM10R3	●			-75 kPa to 0.25 MPa	1.4	20	13	34	Standard: 1.5 Power saving option Holding: 1 (With power saving circuit)	●	●	●	●
	LVM10R4		●											
	LVM10R6	●												
	LVM105R			●										
Base mounted 	LVM15R3	●			-75 kPa to 0.25 MPa [Max. 0.6 MPa]	1.6 [1]	50	16	45	Holding: 1 (With power saving circuit)	●	●	●	●
	LVM15R4		●											
	New LVM15R6	●												
	LVM155R			●										
Body ported 	LVM20R1	●			-75 kPa to 0.25 MPa	2	84	20	80	Standard: 2.5 Power saving option Holding: 0.6 (With power saving circuit)	—	●	●	●
	LVM20R2		●											
	LVM202R			●										
Base mounted 	LVM20R3	●			-75 kPa to 0.3 MPa	2	84	20	80	Standard: 2.5 Power saving option Holding: 0.6 (With power saving circuit)	●	●	●	●
	LVM20R4		●											
	LVM205R			●										

The [] indicate the values of the high-pressure type.

Piping/Mounting Variations

Piping/ Mounting Model	Body ported	Base mounted		Page
		Without sub-plate	With sub-plate	
LVM07	—		—	7
LVM09/090			—	11
LVM10/100	 <p>Manual override (Option)</p> <p>Tubing (Provided by the customer)</p> <p>Bracket</p>	 <p>Base (Provided by the customer)</p> <p>Ring</p>	 <p>Material: PFA or PVDF</p>	17
LVM15/150	—		 <p>Material: PVDF</p>	24
LVM20/200			 <p>Material: PVDF</p>	29

Direct Operated Poppet Type LVM11/13

Less clogging due to the poppet construction

- Isolated structure
The solenoid drive body is separated from the fluid area by a diaphragm.
- Fluid contact material (Metal-free)

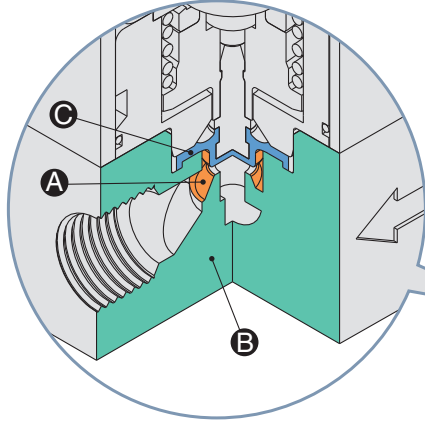

- A** Volume of valve chamber
- B** Body material: PEEK
- C** Diaphragm material: EPDM, FKM, or Kalrez®

* Kalrez® is a registered trademark of E. I. du Pont de Nemours and Company or its affiliates.

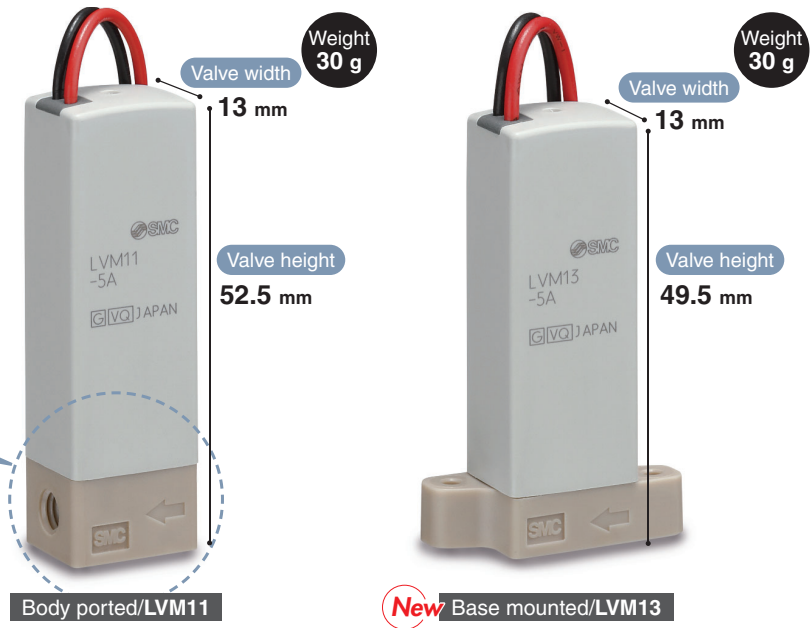

Electrical entry

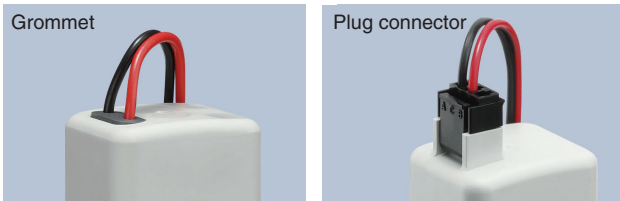

- Orifice diameter: 1.5 mm
- Volume of valve chamber Unit: μL

Model	LVM11	LVM13
Volume of valve chamber	11	13

Power saving circuit standardised

Holding power consumption can be reduced substantially. Continuous energization for extended periods of time is possible.

Model		LVM11	LVM13
Power consumption	Inrush	2.5	2.5
	Holding	1	1

Refer to 10 in "Design / Selection" on page 41 if the valve is to be energized continuously for extended periods of time or used with a manifold.

- With light/surge voltage suppressor
- With reverse mounting prevention pin (Option)
- Application: Liquid discharge, etc.

Series Variations

	Model	Valve type		Operating pressure range	Orifice dia. [mm]	Volume of valve chamber [μL]	Valve width [mm]	Weight [g]	Power consumption [W]	Options			Body ported	Base mounted		Page
		N.C. (2-port)	N.O. (2-port)							Reverse mounting prevention pin	Electrical entry	With light/surge voltage suppressor		Without sub-plate	With sub-plate	
Body ported	LVM11	●		0 to 0.25 MPa	1.5	11	13	30	Inrush: 2.5 Holding: 1	—	●	●	●	●	—	36
Base mounted	New LVM13	●		0 to 0.25 MPa	1.5	13	13	30	Inrush: 2.5 Holding: 1	●	●	●	●	—	—	

CONTENTS

Compact Direct Operated 2/3-Port Solenoid Valve for Chemical Liquids *LVM Series*



Direct Operated Rocker Type LVM07 Series

How to Order	p. 7
Specifications	p. 8
Flow Rate Characteristics	p. 8
Construction: Base mounted	p. 9
Dimensions: Base mounted	p. 10

Direct Operated Rocker Type LVM09/090 Series

How to Order	p. 11
Specifications	p. 12
Flow Rate Characteristics	p. 12
Construction: Body ported	p. 13
Construction: Base mounted	p. 14
Dimensions: Body ported	p. 15
Dimensions: Base mounted	p. 16

Direct Operated Rocker Type LVM10/100 Series

How to Order	p. 17
Specifications	p. 18
Flow Rate Characteristics	p. 18
Construction: Body ported	p. 19
Construction: Base mounted	p. 20
Dimensions: Body ported	p. 21
Dimensions: Base mounted	p. 22

Direct Operated Rocker Type LVM15/150 Series

How to Order	p. 24
Specifications	p. 25
Flow Rate Characteristics	p. 25
Construction: Base mounted	p. 26
Dimensions: Base mounted	p. 27

Direct Operated Rocker Type LVM20/200 Series

How to Order	p. 29
Specifications	p. 30
Flow Rate Characteristics	p. 30
Construction: Body ported	p. 31
Construction: Base mounted	p. 32
Dimensions: Body ported	p. 33
Dimensions: Base mounted	p. 34

Direct Operated Poppet Type LVM11/13 Series

How to Order	p. 36
Specifications	p. 37
Flow Rate Characteristics	p. 37
Construction	p. 38
Dimensions: Body ported	p. 39
Dimensions: Base mounted	p. 40

Specific Product Precautions	p. 41
Spare Parts	p. 44
Safety Instructions	Back cover

Direct Operated Rocker Type



Compact Direct Operated 2-Port Solenoid Valve for Chemical Liquids **LVM07 Series**

How to Order

Base mounted LVM **07R6** - **5** **A** - - **Q**

1
 2
 3
 4
 5
 6



Without sub-plate
Base mounted

1 Number of ports, Valve type

Symbol	Number of ports	Valve type	
07R6	2	N.C.	 IN (Symbol 1) OUT (Symbol 2)

2 Power saving circuit

—	None (Standard type)
Y1	Yes

3 Coil voltage

Symbol	Voltage
5	24 VDC
6	12 VDC

4 Fluid contact material

Symbol	Body	Diaphragm
A	PEEK	EPDM
B	PEEK	FKM
C	PEEK	Kalrez®

5 Reverse mounting prevention pin

—	None
P	Yes

Reverse mounting prevention pin

6 Lead wire length

—	150 mm
3	300 mm
6	600 mm

* Kalrez® is a registered trademark of E. I. du Pont de Nemours and Company or its affiliates.

Mounting screws are included. (2 pcs.)
M1.6 x 8.5/With spring washer (Material: Stainless steel)
For other spare parts, refer to page 44.

Specifications



Without sub-plate
Base mounted

Model		Base mounted	
		LVM07R6	
Valve construction		Direct operated rocker type	
Valve type		N.C.	
Number of ports		2	
Fluid*1		Air, Water, DI water (Pure water), Diluent, or Cleaning fluid	
Operating pressure range		-75 kPa to 0.1 MPa	
Orifice diameter		0.8 mm	
Response time*8		10 ms or less (at pneumatic pressure)	
Leakage		Zero leakage, both internal or external (at water pressure)	
Proof pressure*2		0.15 MPa	
Ambient temperature*9		0 to 50 °C (No condensation)	
Fluid temperature*9		0 to 50 °C	
Volume of valve chamber*3		8 μL	
Mounting orientation*4		Free	
Enclosure		IP40 or equivalent	
Weight		7 g	
Rated voltage		12, 24 VDC	
Allowable voltage fluctuation*5		±10 % of rated voltage	
Type of coil insulation		Class B	
Power consumption (When rated voltage is at 24 V)	Standard type	2.8 W (0.12 A)*6	
	With power saving circuit	Inrush	2.8 W (0.12 A)
		Holding	0.8 W
Coil switching noise*7		50 dB	

*1 Select an appropriate fluid contact material according to the fluid to be used. Additionally, check the chemical resistance beforehand.

*2 Indicates the pressure which does not generate breakage or cracks after a one-minute airtight test

*3 Indicates the volume of clearance inside the valve chamber after the volume of the diaphragm is subtracted

*4 When residual liquid needs to be taken into consideration, mounting in a vertical direction with the coil at the top is recommended. When residual liquid need not be taken into consideration, any mounting orientation is available.

*5 When response time is prioritized, control the voltage so that there is no fluctuation below the rated voltage.

*6 The LVM07R6 (standard type) requires power saving control. Conduct power saving control according to the figure below.

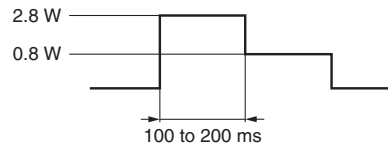

*7 The value is based on SMC's measurement conditions. The noise level will vary according to the actual conditions.

*8 In compliance with JIS B 8 4 1 9 : 2 0 1 0 (Value at ambient and fluid temperatures of 2 5 °C, rated voltage, max. operating pressure (air), and when the N.C. (IN) port is pressurised)

The response time will vary depending on the supply pressure, fluid, piping conditions, and ambient temperature.

*9 When the diaphragm material is Kalrez®, the valve changeover time will be significantly longer at ambient and fluid temperatures of 15 °C or less when compared to the valve changeover time at room temperature (≈ 25 °C).

Flow Rate Characteristics

Water		Air	
Kv	Cv	C	b
0.004	0.005	0.02	0.2

* The values of Kv and Cv are based on JIS B 2005:1995; the values of C and b are based on JIS B 8390:2000.

* Kalrez® is a registered trademark of E. I. du Pont de Nemours and Company or its affiliates.

LVM07 Series

Construction

Base mounted LVM07R6

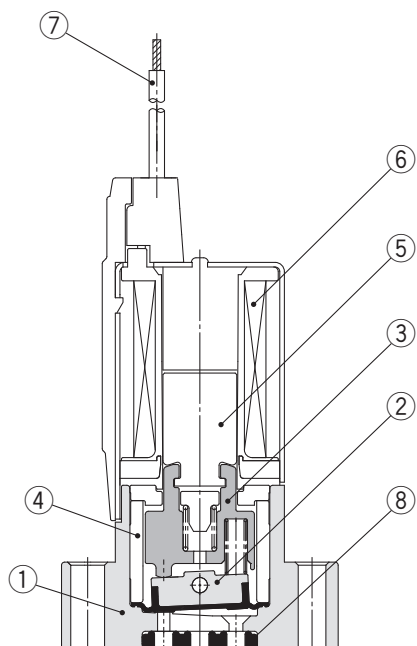

Component Parts

No.	Description	Material
1	Body	PEEK
2	Diaphragm assembly	EPDM/FKM/Kalrez®
3	Slide bushing assembly	PPS/Stainless steel
4	Bushing	PPS
5	Armature	—
6	Coil assembly	—
7	Lead wire	—
8	Interface gasket	EPDM/FKM/Kalrez®

* Kalrez® is a registered trademark of E. I. du Pont de Nemours and Company or its affiliates.

Dimensions

Base mounted LVM07R6

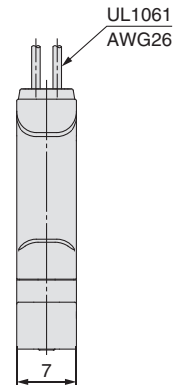
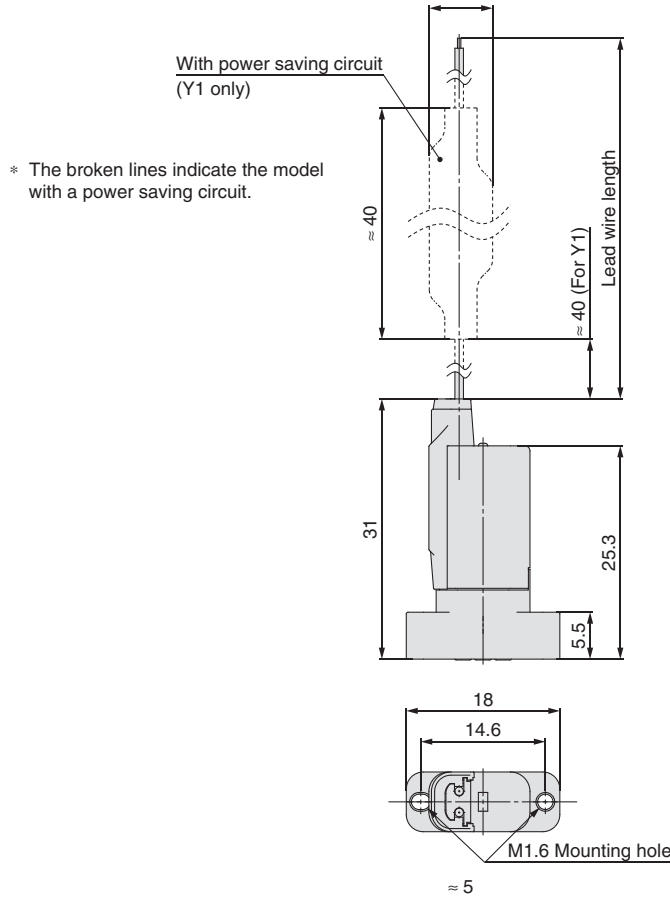
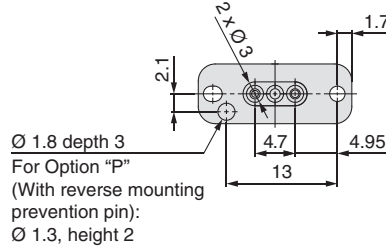

Recommended interface dimensions * Surface roughness = Rz3.2 or less

When using a positioning pin for mounting, the size should be $\text{Ø } 1.5$, and the height should be 2 or less.

For Option "P" (With reverse mounting prevention pin), the size should be $\text{Ø } 1.5$, and the depth

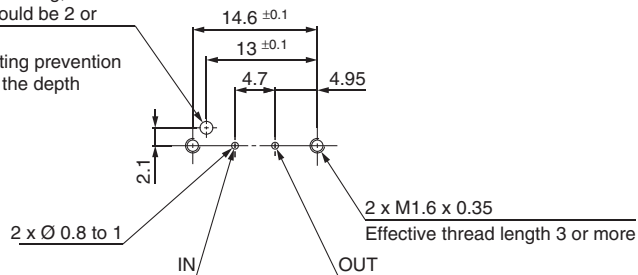

LVM07

LVM09/090

LVM10/100

LVM15/150

LVM20/200

LVM11/13

Specific Product Precautions

Spare Parts

Direct Operated Rocker Type



Compact Direct Operated 2/3-Port Solenoid Valve for Chemical Liquids LVM09/090 Series

How to Order

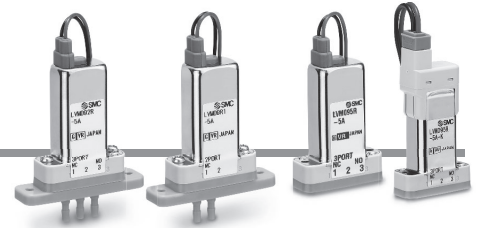

Without sub-plate
Body ported

Without sub-plate
Base mounted

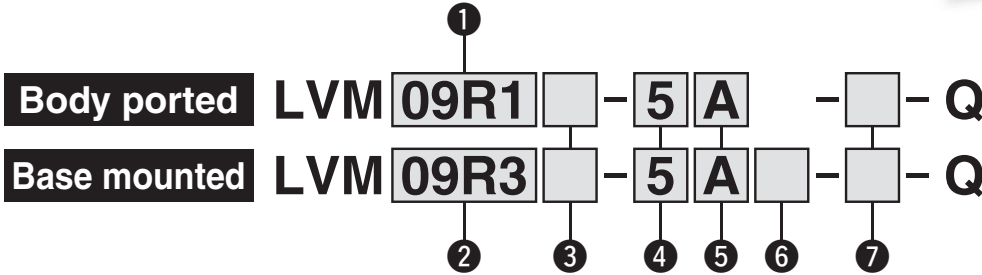

1 Number of ports, Valve type

Symbol	Number of ports	Valve type	
09R1	2	N.C.	
		N.O.	
092R	3	Universal	

3 Power saving circuit

—	None (Standard type)
Y	Yes (Plug connector)
Y1	Yes (Grommet)

4 Coil voltage

Symbol	Voltage
5	24 VDC
6	12 VDC

5 Fluid contact material

Symbol	Plate	Diaphragm
A	PEEK	EPDM
B	PEEK	FKM
C	PEEK	Kalrez®

6 Reverse mounting prevention pin

—	None
P	Yes

2 Number of ports, Valve type

Symbol	Number of ports	Valve type	
09R3	2	N.C.	
09R4		N.O.	
09R6		N.C.	
095R	3	Universal	

7 Electrical entry, Lead wire length, Light/surge voltage suppressor

Symbol	Electrical entry, Lead wire length	Light/surge voltage suppressor	
—	Grommet, 150 mm	Cannot be selected	
3	Grommet, 300 mm		
6	Grommet, 600 mm		
K	Plug connector, 300 mm	None	
KO	Plug connector, Without connector		
KZ	Plug connector, 300 mm	Yes * Power saving circuit "Y" is equipped with a light/surge voltage suppressor.	
KOZ	Plug connector, Without connector		

- * "3" or "6" must be selected for power saving circuit "Y1" (grommet). "—" cannot be selected.
- * The plug connector is included but does not come assembled.
- * If a lead wire length of 600 mm or more is required, select "KO□" (Without connector) and then add the connector part number shown below under the valve part number when ordering.

Plug connector part no.: SY100 - 30 - 4A -

Lead wire length ●

6	600 mm
10	1000 mm
30	3000 mm

Mounting screws are included with the base-mounted type. (2 pcs.)
M2 x 11/With spring washer (Material: Stainless steel)

For other spare parts, refer to page 44.

* Kalrez® is a registered trademark of E. I. du Pont de Nemours and Company or its affiliates.

Specifications

Model	Body ported			Base mounted			
	LVM09R1	LVM09R2	LVM092R	LVM09R3	LVM09R4	LVM09R6	LVM095R
Valve construction	Direct operated rocker type						
Valve type	N.C.	N.O.	Universal	N.C.	N.O.	N.C.	Universal
Number of ports	2		3	2		3	
Fluid*1	Air, Water, DI water (Pure water), Diluent, or Cleaning fluid						
Operating pressure range	-75 kPa to 0.2 MPa						
Orifice diameter	1 mm			1.1 mm			
Response time*7	10 ms or less (at pneumatic pressure)						
Leakage	Zero leakage, both internal or external (at water pressure)						
Proof pressure*2	0.3 MPa						
Ambient temperature*8	0 to 50 °C						
Fluid temperature*8	0 to 50 °C (No freezing)						
Volume of valve chamber*3	18 μL			18 μL		29 μL	18 μL
Mounting orientation*4	Free						
Enclosure	IP40 or equivalent						
Weight	22 g			20 g			
Rated voltage	12, 24 VDC						
Allowable voltage fluctuation*5	±10 % of rated voltage						
Type of coil insulation	Class B						
Power consumption (When rated voltage is at 24 V)	Standard type		2 W (0.08 A)				
	With power saving circuit	Inrush	3.3 W (0.14 A)				
		Holding	0.9 W				
Coil switching noise*6	50 dB						

- *1 Select an appropriate fluid contact material according to the fluid to be used. Additionally, check the chemical resistance beforehand.
- *2 Indicates the pressure which does not generate breakage or cracks after a one-minute airtight test
- *3 Indicates the volume of clearance inside the valve chamber after the volume of the diaphragm is subtracted
- *4 Since the body (orifice shape) is designed to eliminate residual liquid, mounting in a vertical direction with the coil at the top is recommended. When residual liquid need not be taken into consideration, any mounting orientation is available.
- *5 When response time is prioritized, control the voltage so that there is no fluctuation below the rated voltage.
- *6 The value is based on SMC's measurement conditions. The noise level will vary according to the actual conditions.
- *7 In compliance with JIS B 8419:2010
(Value at ambient and fluid temperatures of 25 °C, rated voltage, max. operating pressure (air), and when the N.C. (IN) port is pressurised)
The response time will vary depending on the supply pressure, fluid, piping conditions, and ambient temperature.
- *8 When the diaphragm material is Kalrez®, the valve changeover time will be significantly longer at ambient and fluid temperatures of 15 °C or less when compared to the valve changeover time at room temperature (≈ 25 °C).
- * Refer to 10 in "Design / Selection" on page 41 if the valve is to be energized continuously for extended periods of time.

Flow Rate Characteristics

Water		Air	
Kv	Cv	C	b
0.015	0.018	0.06	0.2

* The values of Kv and Cv are based on JIS B 2005:1995; the values of C and b are based on JIS B 8390:2000.

* Kalrez® is a registered trademark of E. I. du Pont de Nemours and Company or its affiliates.



Without sub-plate
Body ported



Without sub-plate
Body ported



Without sub-plate
Base mounted



Without sub-plate
Base mounted

LVM07

LVM09/090

LVM10/100

LVM15/150

LVM20/200

LVM11/13

Specific Product
Precautions

Spare Parts

LVM09/090 Series

Construction

Body ported
LVM09R1

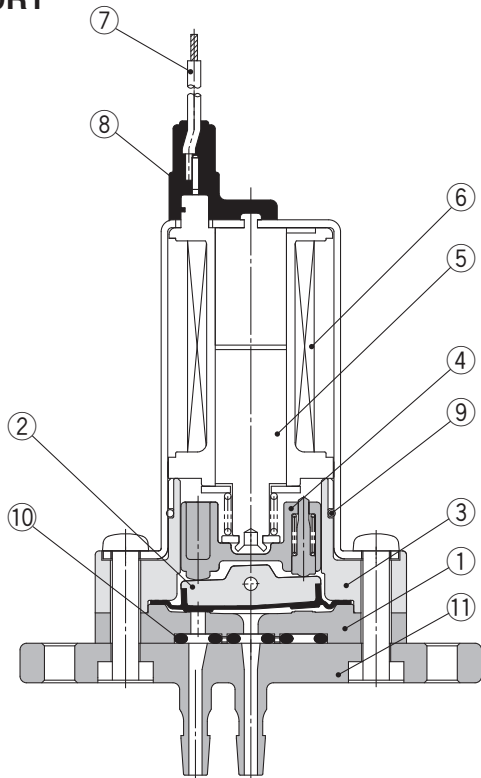

LVM09R2

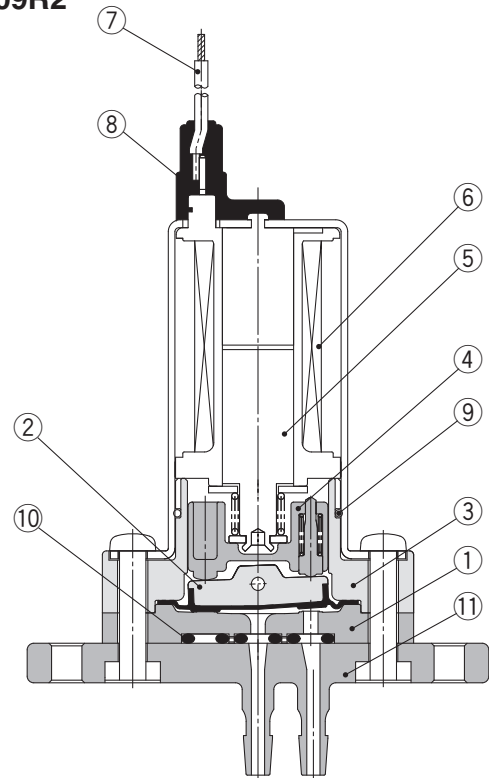

LVM092R

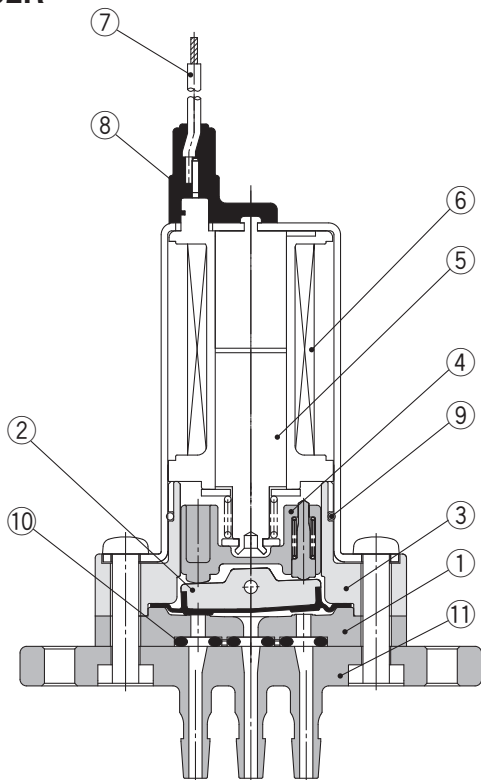

Component Parts: LVM09R1, 09R2, 092R

No.	Description	Material
1	Plate	PEEK
2	Diaphragm assembly	EPDM/FKM/Kalrez®
3	Body	PBT
4	Slide bushing assembly	PPS/Stainless steel
5	Armature assembly	—
6	Coil assembly	—
7	Lead wire	—
8	Mold	PET
9	O-ring	NBR
10	Interface gasket	EPDM/FKM/Kalrez®
11	Piping plate	PEEK

* Kalrez® is a registered trademark of E. I. du Pont de Nemours and Company or its affiliates.

Construction

Base mounted
LVM09R3

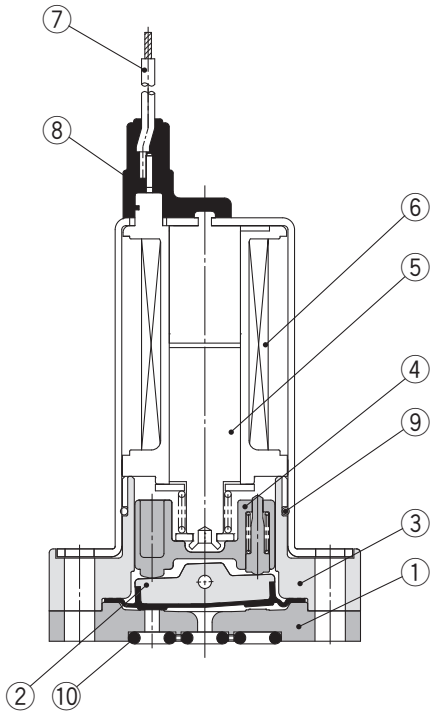

LVM09R4

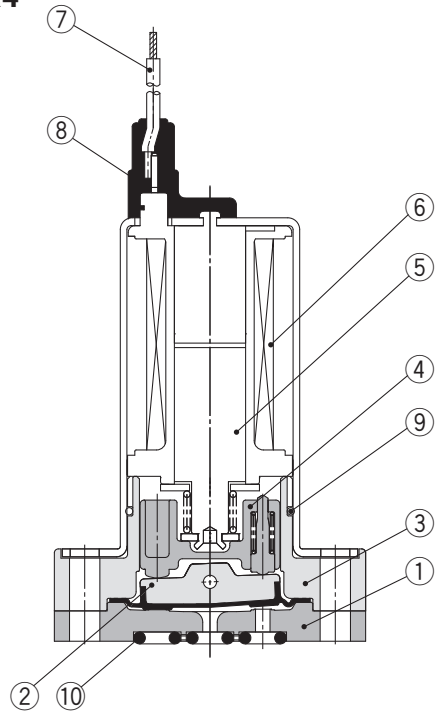

LVM09R6

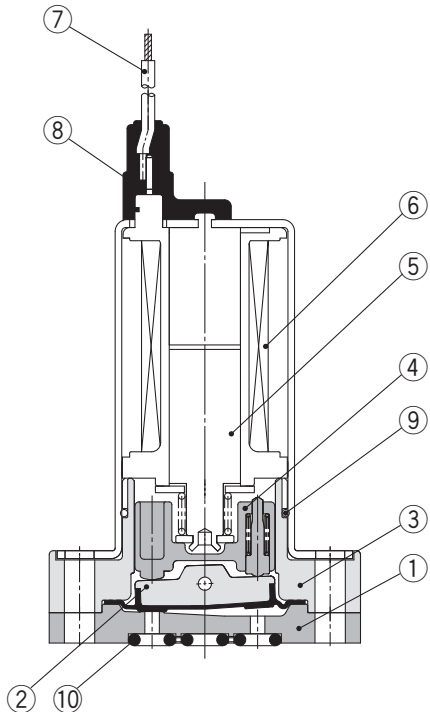

LVM095R

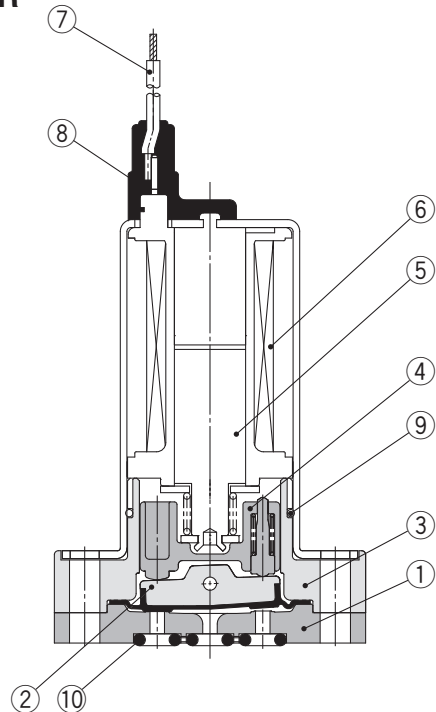

Component Parts: LVM09R3, 09R4, 09R6, 095R

No.	Description	Material
1	Plate	PEEK
2	Diaphragm assembly	EPDM/FKM/Kalrez®
3	Body	PBT
4	Slide bushing assembly	PPS/Stainless steel
5	Armature assembly	—

No.	Description	Material
6	Coil assembly	—
7	Lead wire	—
8	Mold	PET
9	O-ring	NBR
10	Interface gasket	EPDM/FKM/Kalrez®

* Kalrez® is a registered trademark of E. I. du Pont de Nemours and Company or its affiliates.

LVM09/090 Series

Dimensions

Body ported
LVM09R1
LVM09R2
LVM092R

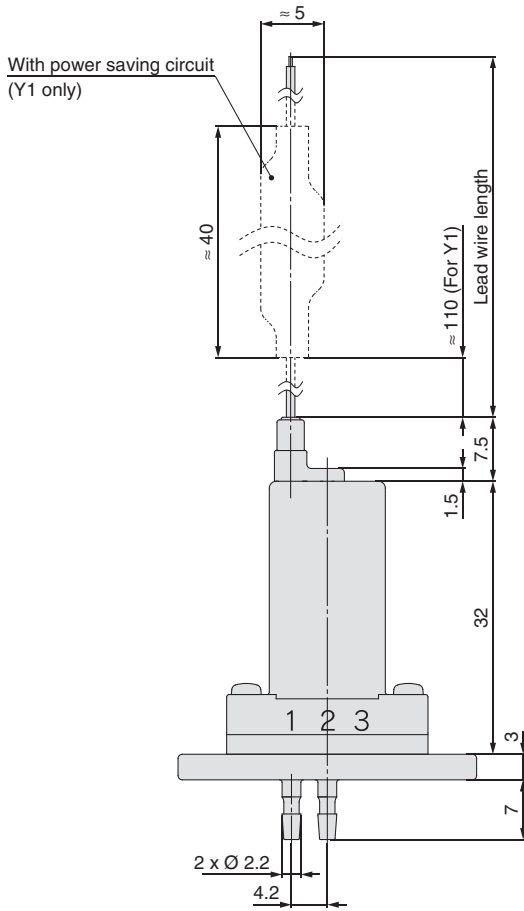
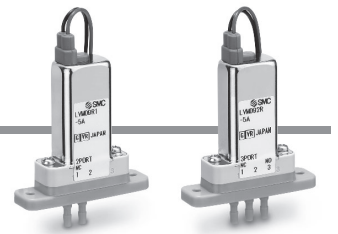

LVM09R1

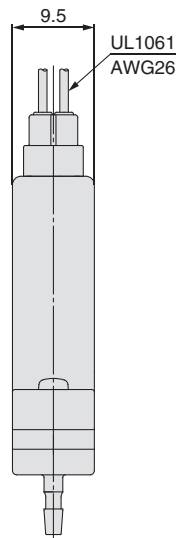
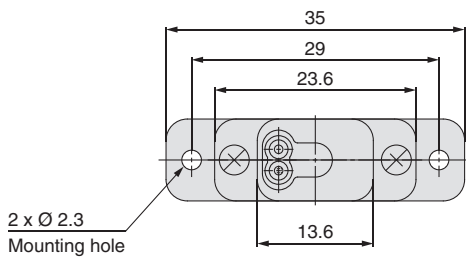

* The broken lines indicate the model with a power saving circuit.

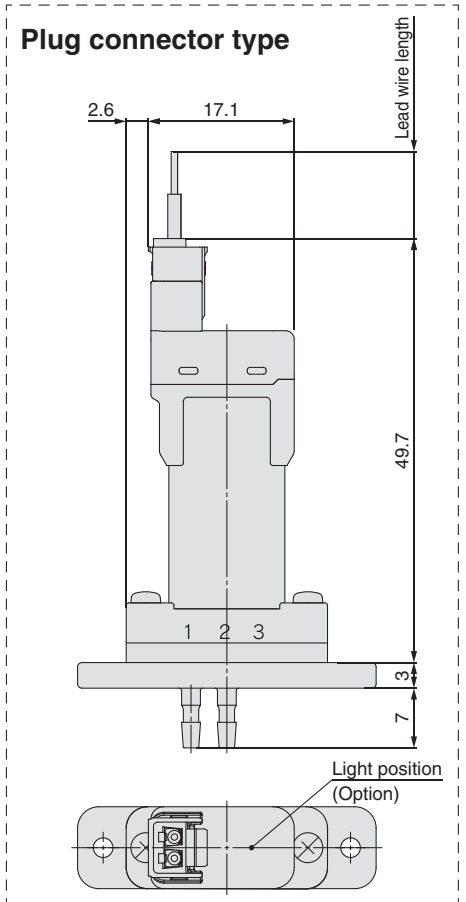

LVM09R2

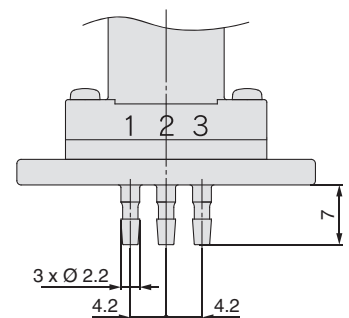
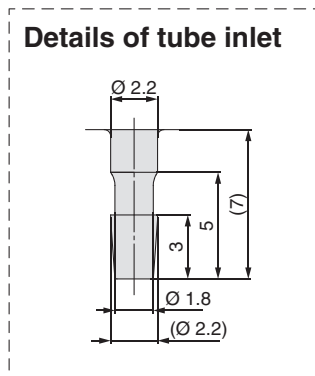
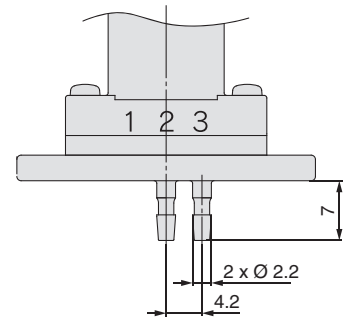

LVM092R

Dimensions

Base mounted, Without sub-plate

LVM09R3/6-□□-□ (N.C.)

LVM09R4-□□-□ (N.O.)

LVM095R-□□-□ (Universal)

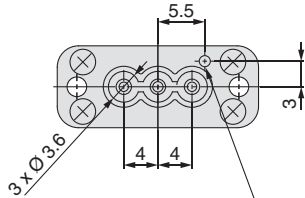
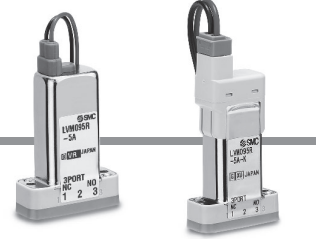

LVM095R

Ø 1.2 depth 1.8
For Option "P"
(With reverse mounting prevention pin):
Ø 1.5, height 2

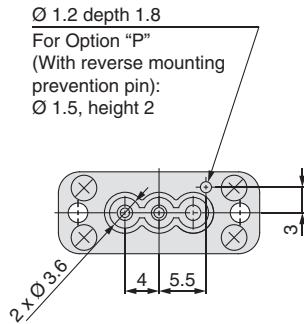

LVM09R3

Ø 1.2 depth 1.8
For Option "P"
(With reverse mounting prevention pin):
Ø 1.5, height 2

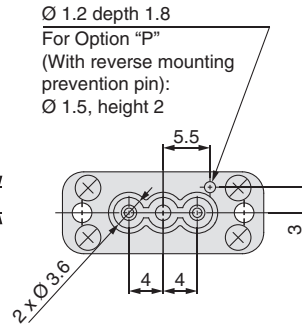

LVM09R6

Ø 1.2 depth 1.8
For Option "P"
(With reverse mounting prevention pin):
Ø 1.5, height 2

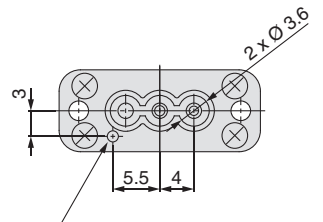

LVM09R4

Ø 1.2 depth 1.8
For Option "P"
(With reverse mounting prevention pin): Ø 1.5, height 2

Plug connector type

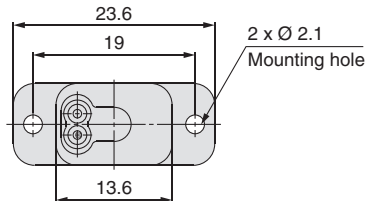
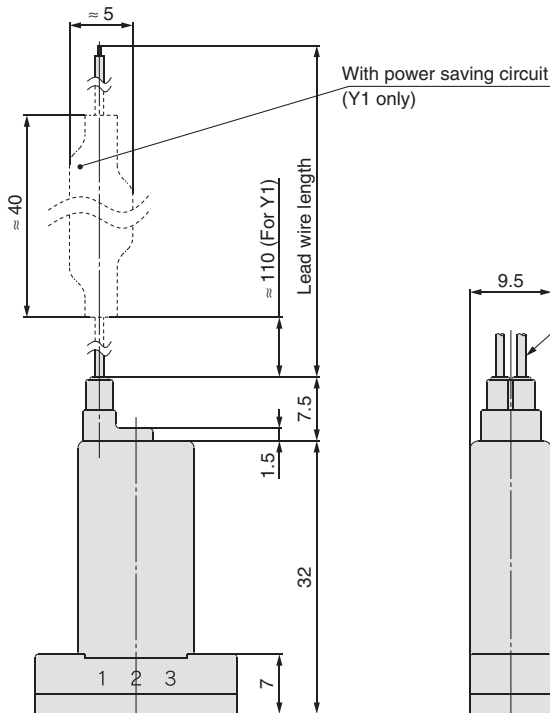
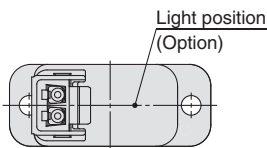
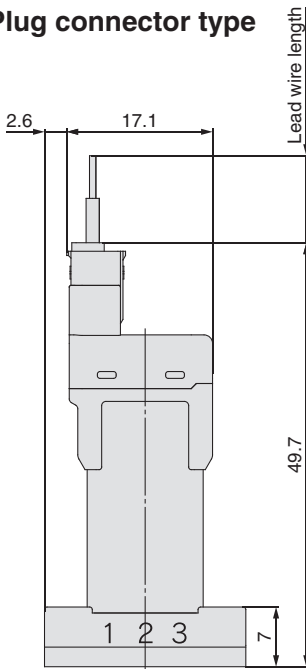

* The broken lines indicate the model with a power saving circuit.

Recommended interface dimensions * Surface roughness = Rz3.2 or less

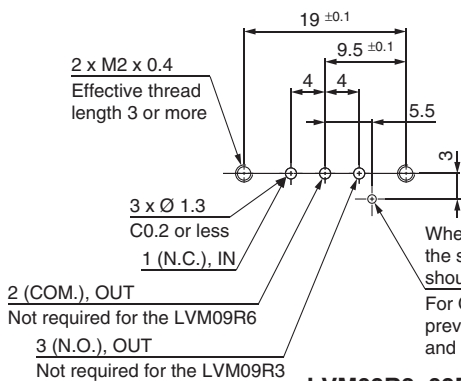

LVM09R3, 09R6, 095R

When using a positioning pin for mounting, the size should be Ø 1, and the height should be 1.5 or less.
For Option "P" (With reverse mounting prevention pin), the size should be Ø 1.7, and the depth should be 2.3 or more.

When using a positioning pin for mounting, the size should be Ø 1, and the height should be 1.5 or less.
For Option "P" (With reverse mounting prevention pin), the size should be Ø 1.7, and the depth should be 2.3 or more.

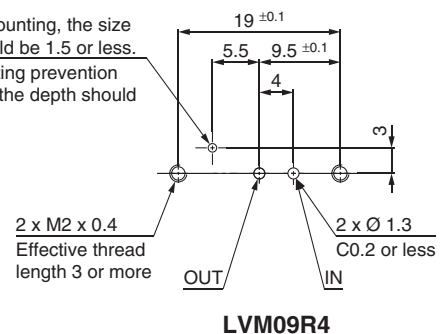

LVM09R4

LVM07

LVM09/090

LVM10/100

LVM15/150

LVM20/200

LVM11/13

Specific Product Precautions

Spare Parts

Compact Direct Operated 2/3-Port Solenoid Valve for Chemical Liquids LVM10/100 Series

How to Order

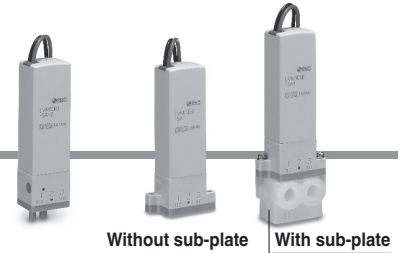

Body ported

Without sub-plate

With sub-plate

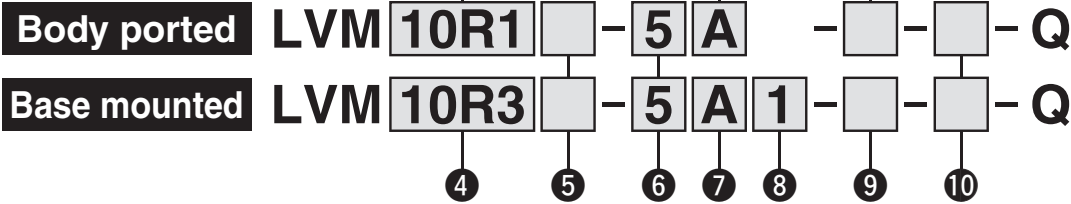

1 Number of ports, Valve type

Symbol	Number of ports	Valve type	
10R1	2	N.C.	
		N.O.	
10R2	2	N.O.	
102R	3	Universal	

2 Fluid contact material

Symbol	Plate	Diaphragm
A	PEEK	EPDM
B	PEEK	FKM
C	PEEK	Kalrez®

3 Option

—	None
1	Bracket
2	Manual override
3	Bracket, Manual override

7 Fluid contact material

Symbol	Plate	Diaphragm
A	PEEK	EPDM
B	PEEK	FKM
C	PEEK	Kalrez®
E	PFA	EPDM
F	PFA	FKM
G	PFA	Kalrez®

8 Sub-plate material/port size, Reverse mounting prevention pin

Symbol	Sub-plate		Reverse mounting prevention pin
	Material	Port size	
—	—	—	None
P	None	—	Yes
			Reverse mounting prevention pin
			None
1	PVDF	M6	None
1U		1/4-28UNF	
2	PFA	M6	
2U		1/4-28UNF	

4 Number of ports, Valve type

Symbol	Number of ports	Valve type	
10R3	2	N.C.	
		N.O.	
10R4	2	N.O.	
10R6	2	N.C.	
105R	3	Universal	

9 Option

—	None
1	Bracket
2	Manual override
3	Bracket, Manual override

* Without a sub-plate, a bracket cannot be attached.

* "P," "1," and "1U" cannot be selected if the wetted parts material is "E," "F," or "G."
* A sub-plate cannot be mounted for "P" (With reverse mounting prevention pin).

10 Electrical entry, Lead wire length, Light/surge voltage suppressor

Symbol	Electrical entry, Lead wire length	Light/surge voltage suppressor
—	Grommet, 300 mm	Cannot be selected
6	Grommet, 600 mm	
10	Grommet, 1000 mm	
K	Plug connector, 300 mm	None
KO	Plug connector, Without connector	
KZ	Plug connector, 300 mm	Yes
KOZ	Plug connector, Without connector	

* The plug connector is included but does not come assembled.

* If a lead wire length of 600 mm or more is required, select "KO□" (Without connector) and then add the connector part number shown below under the valve part number when ordering.

Plug connector part no.: AXT661 - 14A - □

Lead wire length

6	600 mm
10	1000 mm
20	2000 mm
30	3000 mm

Mounting screws are included with the base-mounted type. (2 pcs.)
M2 x 11/With spring washer (Material: Stainless steel)

For other spare parts, refer to page 44.

5 Power saving circuit

—	None (Standard type)
Y	Yes

6 Coil voltage

Symbol	Voltage
5	24 VDC
6	12 VDC

* Kalrez® is a registered trademark of E. I. du Pont de Nemours and Company or its affiliates.

Specifications



Body ported



Without sub-plate
Base mounted



With sub-plate
Base mounted

Model	Body ported (Tube connection type)			Base mounted			
	LVM10R1	LVM10R2	LVM102R	LVM10R3	LVM10R4	LVM10R6	LVM105R
Valve construction	Direct operated rocker type						
Valve type	N.C.	N.O.	Universal	N.C.	N.O.	N.C.	Universal
Number of ports	2		3	2		3	
Fluid*1	Air, Water, DI water (Pure water), Diluent, or Cleaning fluid						
Operating pressure range	-75 kPa to 0.25 MPa						
Orifice diameter	1.4 mm						
Response time*7	10 ms or less (at pneumatic pressure)						
Leakage	Zero leakage, both internal or external (at water pressure)						
Proof pressure*2	0.38 MPa						
Ambient temperature*8	0 to 50 °C						
Fluid temperature*8	0 to 50 °C (No freezing)						
Volume of valve chamber*3	20 μL						
Mounting orientation*4	Free						
Enclosure	IP40 or equivalent						
Weight	34 g			34 g (Without sub-plate) 42 g (With sub-plate)			
Rated voltage	12, 24 VDC						
Allowable voltage fluctuation*5	±10 % of rated voltage						
Type of coil insulation	Class B						
Power consumption (When rated voltage is at 24 V)	Standard type		1.5 W (0.06 A)				
	With power saving circuit	Inrush	2.5 W (0.1 A)				
		Holding	1 W				
Coil switching noise*6	50 dB						

*1 Select an appropriate fluid contact material according to the fluid to be used. Additionally, check the chemical resistance beforehand.

*2 Indicates the pressure which does not generate breakage or cracks after a one-minute airtight test

*3 Indicates the volume of clearance inside the valve chamber after the volume of the diaphragm is subtracted

*4 Since the body (orifice shape) is designed to eliminate residual liquid, mounting in a vertical direction with the coil at the top is recommended. When residual liquid need not be taken into consideration, any mounting orientation is available.

*5 When response time is prioritized, control the voltage so that there is no fluctuation below the rated voltage.

*6 The value is based on SMC's measurement conditions. The noise level will vary according to the actual conditions.

*7 In compliance with JIS B 8419:2010

(Value at ambient and fluid temperatures of 25 °C, rated voltage, max. operating pressure (air), and when the N.C. (IN) port is pressurised)

The response time will vary depending on the supply pressure, fluid, piping conditions, and ambient temperature.

*8 When the diaphragm material is Kalrez®, the valve changeover time will be significantly longer at ambient and fluid temperatures of 15 °C or less when compared to the valve changeover time at room temperature (≈ 25 °C).

* Refer to 10 in "Design / Selection" on page 41 if the valve is to be energized continuously for extended periods of time.

Flow Rate Characteristics

Water		Air	
Kv	Cv	C	b
0.025	0.03	0.1	0.2

* The values of Kv and Cv are based on JIS B 2005:1995; the values of C and b are based on JIS B 8390:2000.

* Kalrez® is a registered trademark of E. I. du Pont de Nemours and Company or its affiliates.

LVM07

LVM09/090

LVM10/100

LVM15/150

LVM20/200

LVM11/13

Specific Product Precautions

Spare Parts

LVM10/100 Series

Construction

Body ported
LVM10R1

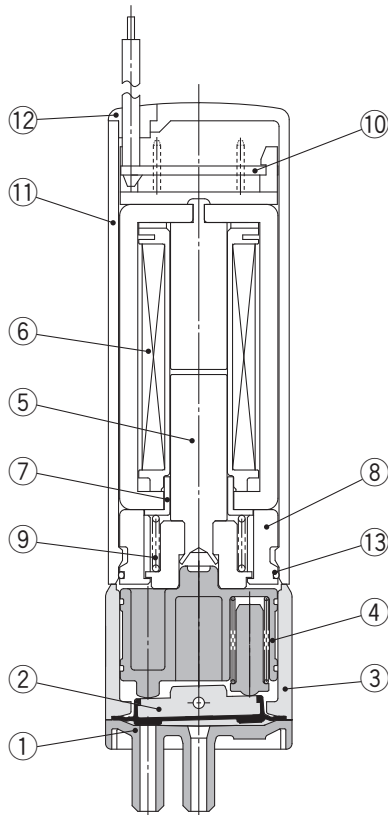

LVM10R2

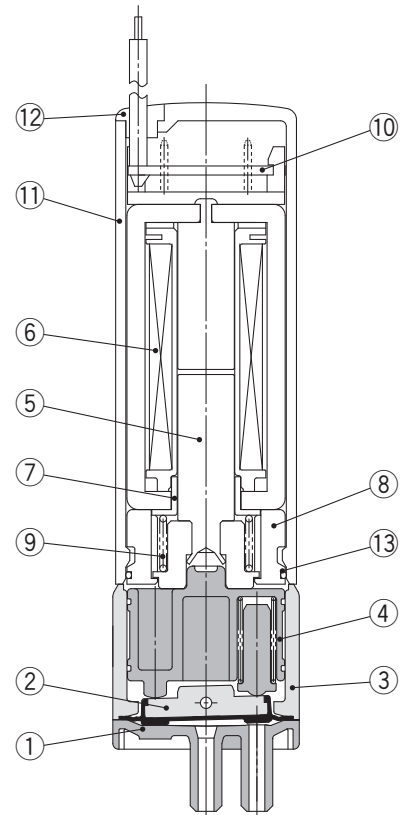

LVM102R

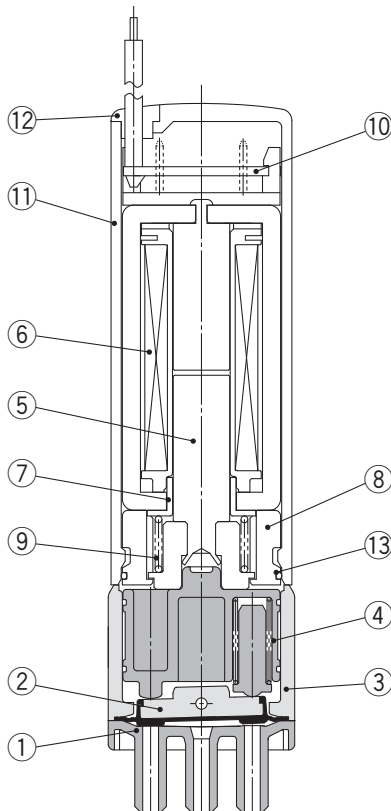

Component Parts: LVM10R1, 10R2, 102R

No.	Description	Material
1	Plate	PEEK
2	Diaphragm assembly	EPDM/FKM/Kalrez®
3	Body	PBT
4	Slide bushing assembly	PPS/Stainless steel
5	Armature assembly	Stainless steel/PBT
6	Coil assembly	—
7	Sleeve	SUY (Iron)
8	Spacer	PBT
9	Return spring	Stainless steel
10	Board assembly	—
11	Casing	PBT
12	Plug	NBR
13	O-ring	NBR

* Kalrez® is a registered trademark of E. I. du Pont de Nemours and Company or its affiliates.

Construction

Base mounted
LVM10R3

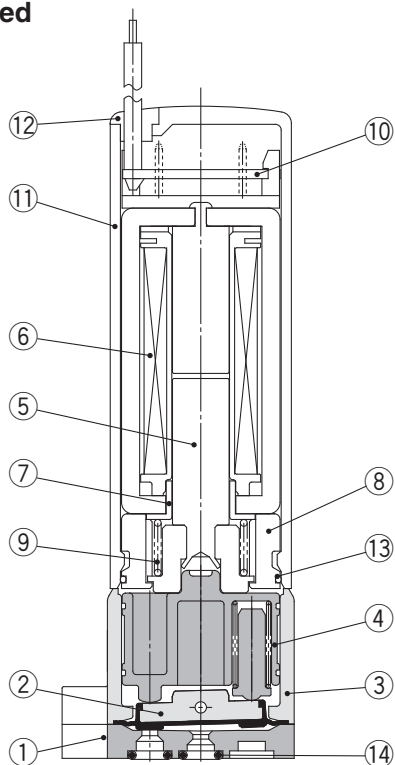

LVM10R4

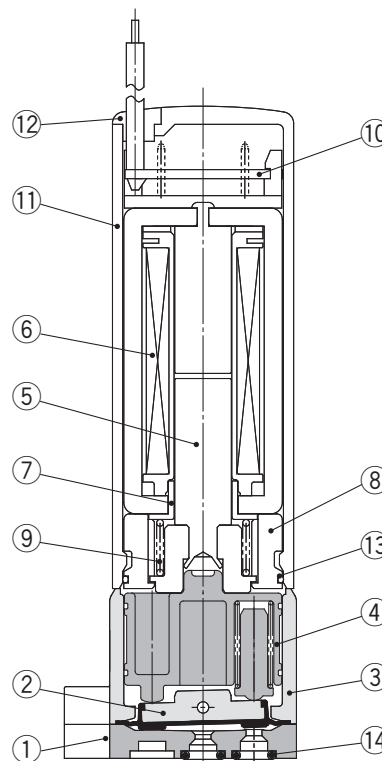

LVM10R6

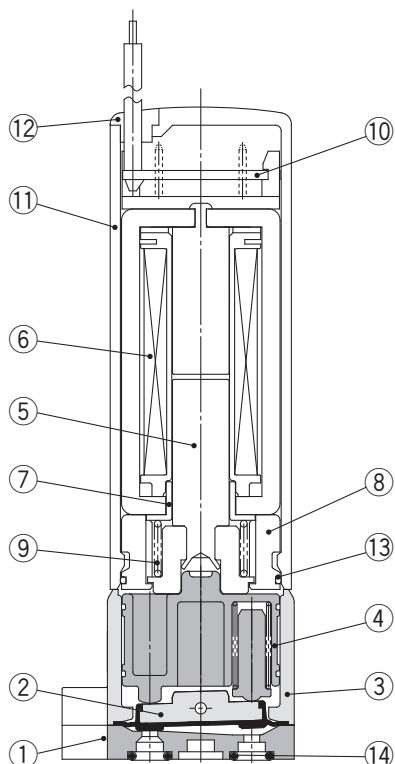

LVM105R

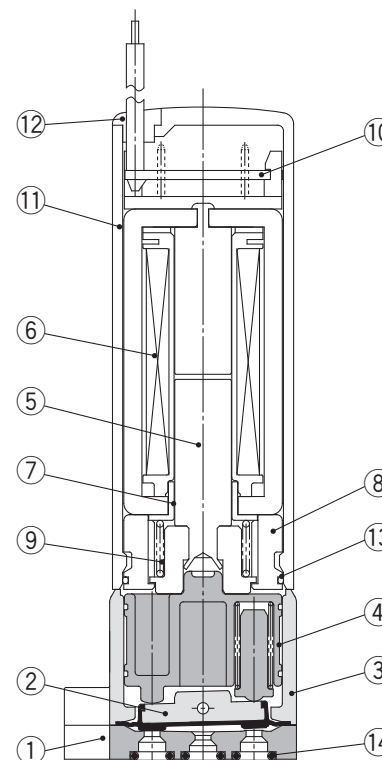

Component Parts: LVM10R3, 10R4, 10R6, 105R

No.	Description	Material
1	Plate	PEEK/PFA
2	Diaphragm assembly	EPDM/FKM/Kalrez®
3	Body	PBT
4	Slide bushing assembly	PPS/Stainless steel
5	Armature assembly	Stainless steel/PBT
6	Coil assembly	—
7	Sleeve	SUY (Iron)

No.	Description	Material
8	Spacer	PBT
9	Return spring	Stainless steel
10	Board assembly	—
11	Casing	PBT
12	Plug	NBR
13	O-ring	NBR
14	O-ring	EPDM/FKM/Kalrez®

* Kalrez® is a registered trademark of E. I. du Pont de Nemours and Company or its affiliates.

LVM07
 LVM09/090
 LVM10/100
 LVM15/150
 LVM20/200
 LVM11/13
 Specific Product Precautions
 Spare Parts

LVM10/100 Series



Dimensions

Body ported

LVM10R1-□□-□ (N.C.)

LVM10R2-□□-□ (N.O.)

LVM102R-□□-□ (Universal)

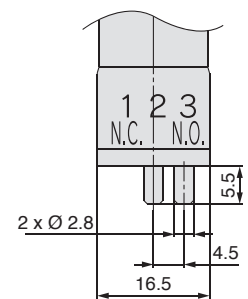
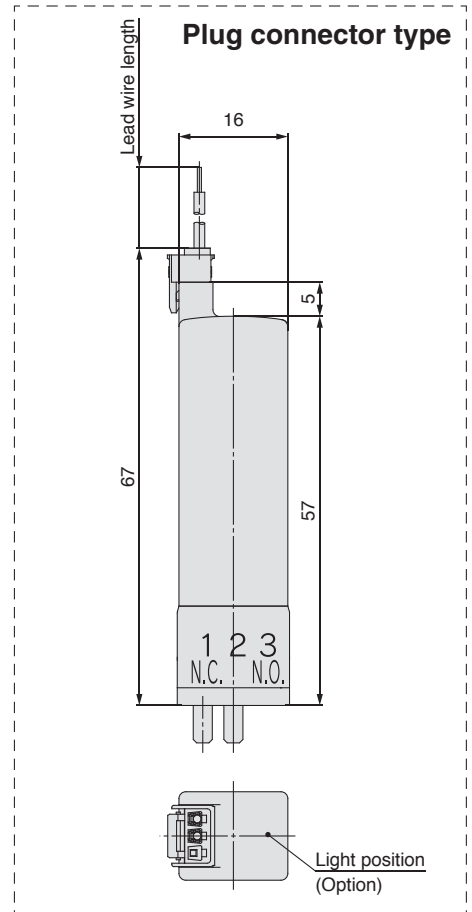
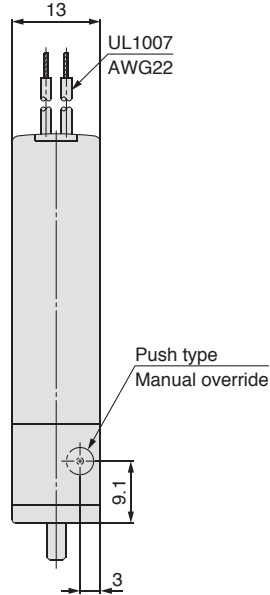
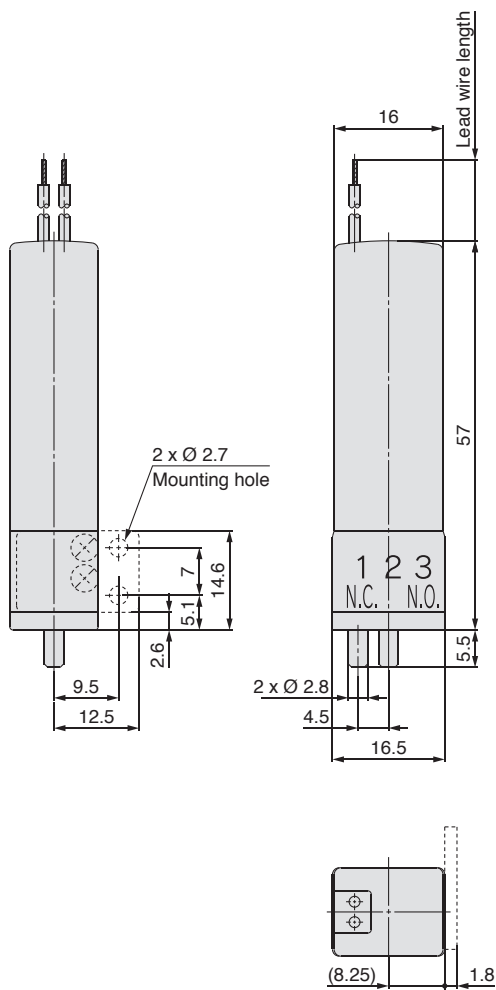

LVM10R2

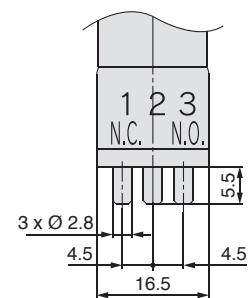

LVM102R

* The broken lines indicate the model with a bracket.



Dimensions

Base mounted, Without sub-plate

LVM10R3-□□-□ (N.C.)

LVM10R4-□□-□ (N.O.)

LVM10R6-□□-□ (N.C.)

LVM105R-□□-□ (Universal)

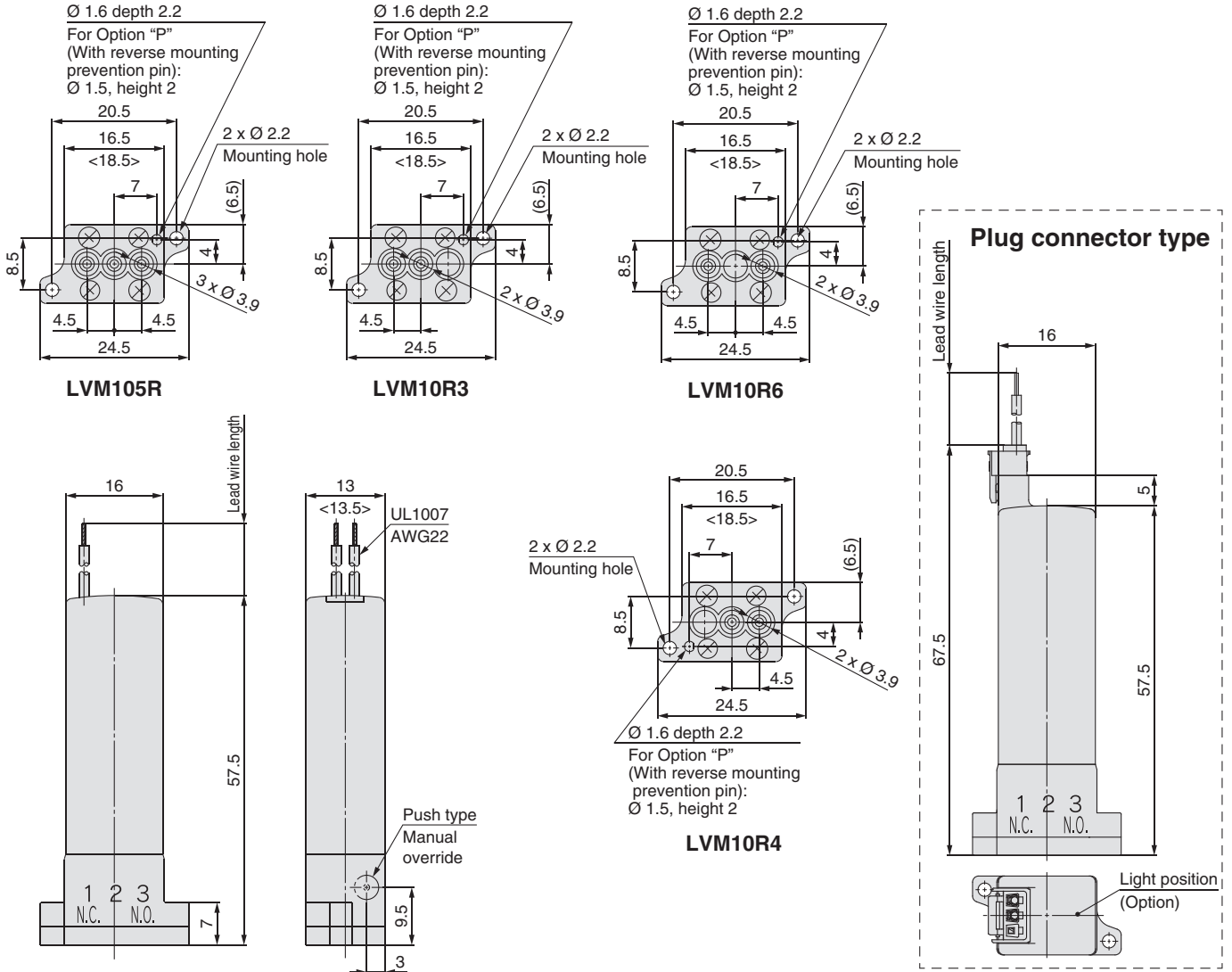

* The figures in brackets < > indicate the values when PFA is selected as the plate material (wetted parts material "E," "F," or "G"). When PFA is selected as the plate material (wetted parts material "E," "F," or "G"), there is no Ø 1.6 positioning hole or Ø 1.5 reverse mounting prevention pin.

Recommended interface dimensions * Surface roughness = Rz3.2 or less

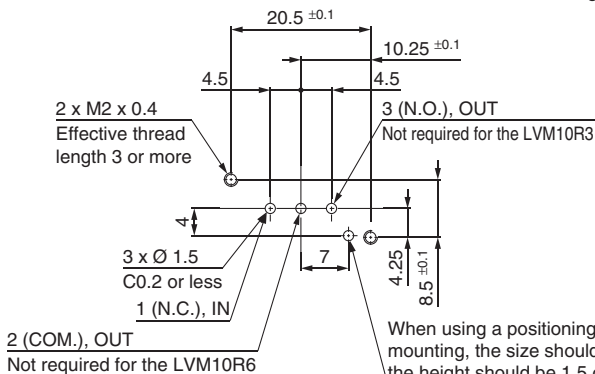

LVM10R3, 10R6, 105R

When using a positioning pin for mounting, the size should be Ø 1, and the height should be 1.5 or less.

For Option "P" (With reverse mounting prevention pin), the size should be Ø 1.7, and the depth should be 2.3 or more.

When using a positioning pin for mounting, the size should be Ø 1, and the height should be 1.5 or less.

For Option "P" (With reverse mounting prevention pin), the size should be Ø 1.7, and the depth should be 2.3 or more.

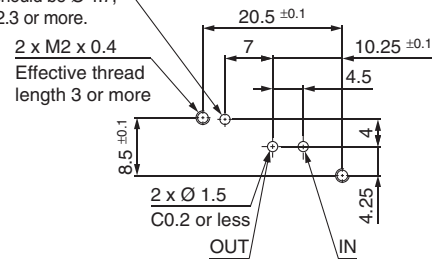

LVM10R4

LVM07

LVM09/090

LVM10/100

LVM15/150

LVM20/200

LVM11/13

Specific Product Precautions

Spare Parts

LVM10/100 Series

Dimensions

Base mounted, With sub-plate

LVM10R3-□□□-□ (N.C.)

LVM10R4-□□□-□ (N.O.)

LVM10R6-□□□-□ (N.C.)

LVM105R-□□□-□ (Universal)

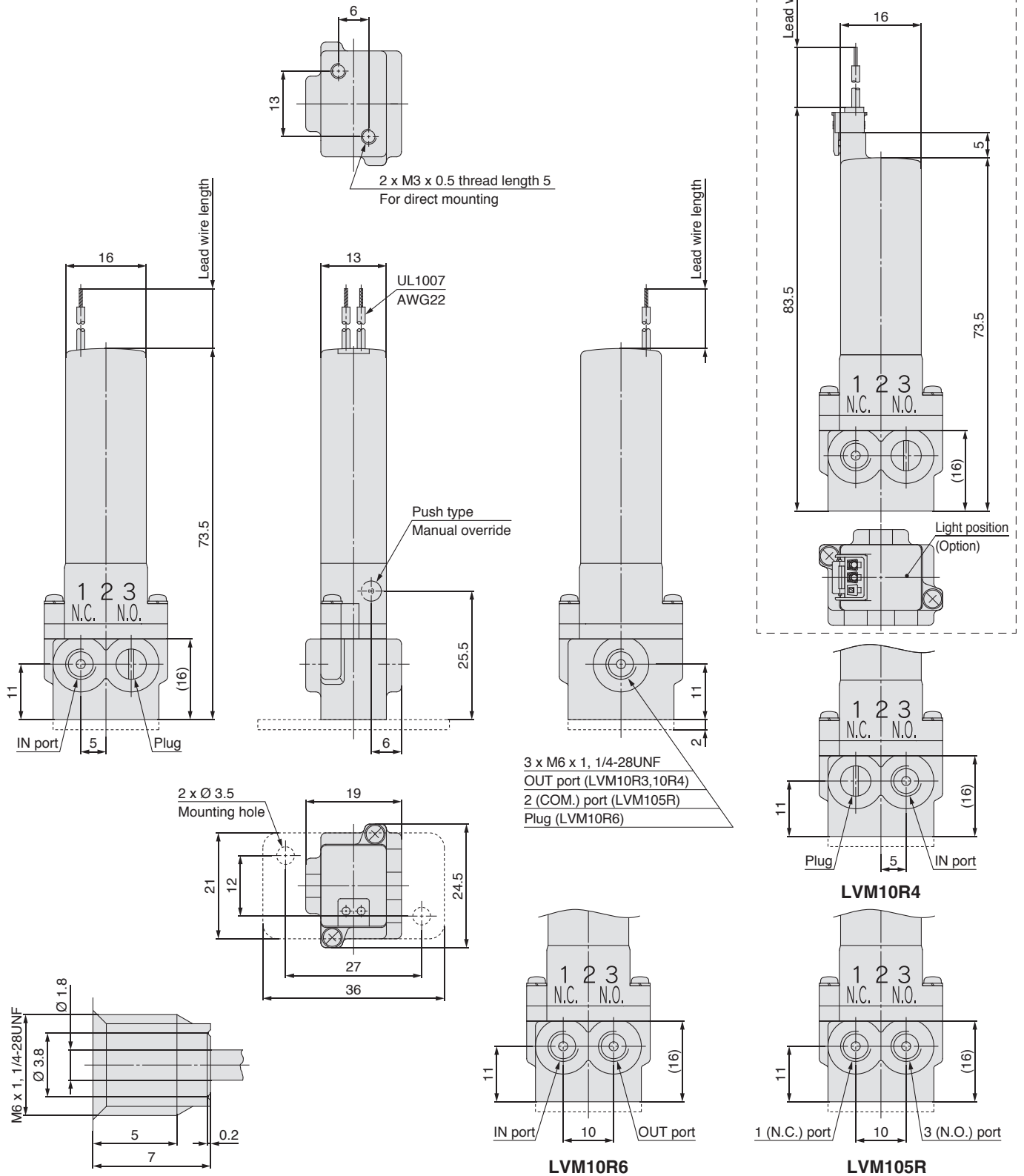

Details of thread

* The broken lines indicate the model with a bracket.

Direct Operated Rocker Type



Compact Direct Operated 2/3-Port Solenoid Valve for Chemical Liquids

LVM15/150 Series

How to Order

Base mounted LVM **15R3** **Y** - **5** **A** **1** - **Q**

①
②
③
④
⑤
⑥



Without sub-plate With sub-plate

① Number of ports, Valve type

Symbol	Number of ports	Valve type	
15R3	2	N.C.	
15R4		N.O.	
15R6		N.C.	
155R	3	Universal	

② Max. operating pressure, Power saving circuit

Symbol	Max. operating pressure	Power saving circuit
Y	0.25 MPa (Standard type)	Yes
HY	0.6 MPa (High-pressure type)	Yes

③ Coil voltage

Symbol	Voltage
5	24 VDC
6	12 VDC

④ Fluid contact material

Symbol	Plate	Diaphragm
A	PEEK	EPDM
B	PEEK	FKM
C	PEEK	Kalrez®

⑤ Sub-plate material/port size, Reverse mounting prevention pin

Symbol	Sub-plate		Reverse mounting prevention pin
	Material	Port size	
—	None	None	None
P			Yes
1	PVDF	M6	None
1U		1/4-28UNF	

* A sub-plate cannot be mounted for "P" (With reverse mounting prevention pin).

⑥ Electrical entry, Lead wire length, Light/surge voltage suppressor

Symbol	Electrical entry, Lead wire length	Light/surge voltage suppressor
—	Grommet, 300 mm	Cannot be selected
6	Grommet, 600 mm	
10	Grommet, 1000 mm	
KZ	Plug connector, 300 mm	Yes
KOZ	Plug connector, Without connector	

* The plug connector is included but does not come assembled.

* If a lead wire length of 600 mm or more is required, select "KOZ" (Without connector) and then add the connector part number shown below under the valve part number when ordering.

Plug connector part no.: AXT661 - 14A -

Lead wire length

6	600 mm
10	1000 mm
20	2000 mm
30	3000 mm

* Kalrez® is a registered trademark of E. I. du Pont de Nemours and Company or its affiliates.

Mounting screws are included. (2 pcs.)
M2.5 x 14/With spring washer (Material: Stainless steel)

For other spare parts, refer to page 44.

LVM15/150 Series

Specifications



Without sub-plate



With sub-plate

Model		Base mounted			
		LVM15R3	LVM15R4	LVM15R6	LVM155R
Valve construction		Direct operated rocker type			
Valve type		N.C.	N.O.	N.C.	Universal
Number of ports		2			3
Fluid *1		Air, Water, DI water (Pure water), Diluent, or Cleaning fluid			
Operating pressure range	Standard type	-75 kPa to 0.25 MPa			
	High-pressure type	Max. 0.6 MPa*7			
Orifice diameter	Standard type	1.6 mm			
	High-pressure type	1 mm			
Response time *8		15 ms or less (at pneumatic pressure)			
Leakage		Zero leakage, both internal or external (at water pressure)			
Proof pressure *2	Standard type	0.38 MPa			
	High-pressure type	0.9 MPa			
Ambient temperature *9		0 to 50 °C			
Fluid temperature *9		0 to 50 °C (No freezing)			
Volume of valve chamber *3		50 μL	60 μL	50 μL	
Mounting orientation *4		Free			
Enclosure		IP40 or equivalent			
Weight		45 g (Without sub-plate), 56 g (With sub-plate)			
Rated voltage		12, 24 VDC			
Allowable voltage fluctuation *5		±10 % of rated voltage			
Type of coil insulation		Class B			
Power consumption (When rated voltage is at 24 V)	Inrush	5.5 W (0.23 A)			
	Holding	1 W			
Coil switching noise *6		60 dB			

*1 Select an appropriate fluid contact material according to the fluid to be used. Additionally, check the chemical resistance beforehand.

*2 Indicates the pressure which does not generate breakage or cracks after a one-minute airtight test

*3 Indicates the volume of clearance inside the valve chamber after the volume of the diaphragm is subtracted

*4 Since the body (orifice shape) is designed to eliminate residual liquid, mounting in a vertical direction with the coil at the top is recommended. When residual liquid need not be taken into consideration, any mounting orientation is available.

*5 When response time is prioritized, control the voltage so that there is no fluctuation below the rated voltage.

*6 The value is based on SMC's measurement conditions. The noise level will vary according to the actual conditions.

*7 The high-pressure type can also be used at a pressure level of up to -7.5 kPa. However, set the maximum operating pressure so that a difference in operating pressure becomes 0.6 MPa or less.

Example) When the valve is used at -50 kPa, the maximum operating pressure is up to 0.55 MPa.

*8 In compliance with JIS B 8419:2010

(Value at ambient and fluid temperatures of 25 °C, rated voltage, max. operating pressure (air), and when the N.C. (IN) port is pressurised)

The response time will vary depending on the supply pressure, fluid, piping conditions, and ambient temperature.

*9 When the diaphragm material is Kalrez®, the valve changeover time will be significantly longer at ambient and fluid temperatures of 15 °C or less when compared to the valve changeover time at room temperature (≈ 25 °C).

* Refer to 10 in "Design / Selection" on page 41 if the valve is to be energized continuously for extended periods of time.

Flow Rate Characteristics

Water		Air	
Kv	Cv	C	b
0.034 [0.012]	0.04 [0.015]	0.13 [0.05]	0.22 [0.2]

The [] indicate the values of the high-pressure type.

* The values of Kv and Cv are based on JIS B 2005:1995; the values of C and b are based on JIS B 8390:2000.

* Kalrez® is a registered trademark of E. I. du Pont de Nemours and Company or its affiliates.

Construction

Base mounted
LVM15R3

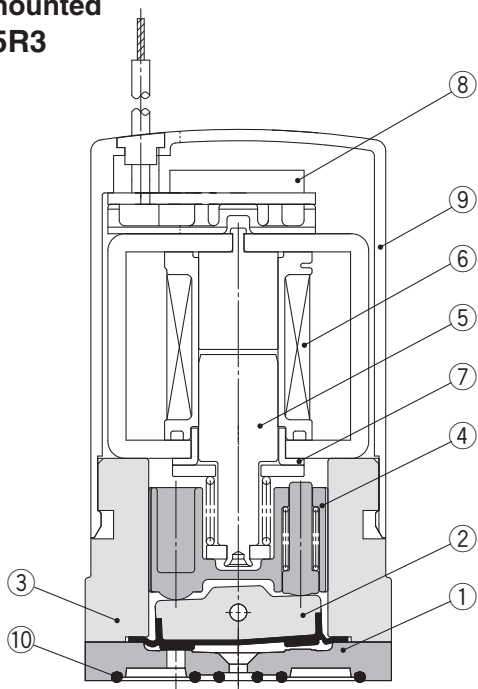

LVM15R4

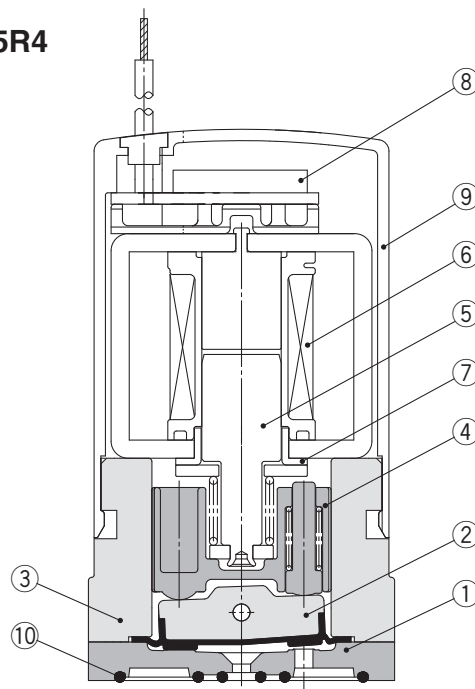

LVM15R6

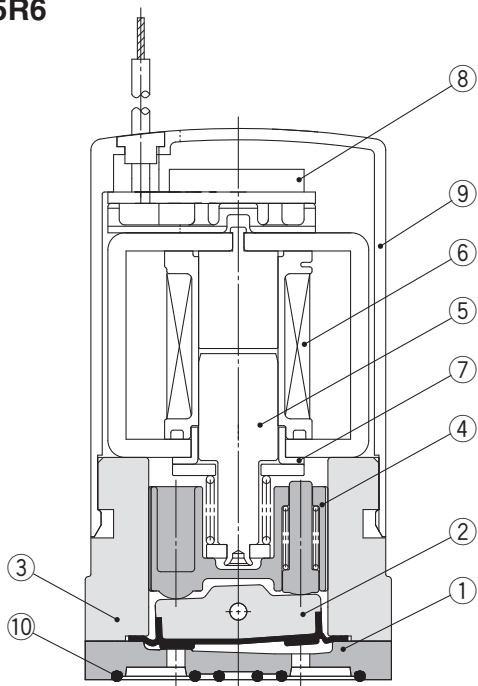

LVM15R

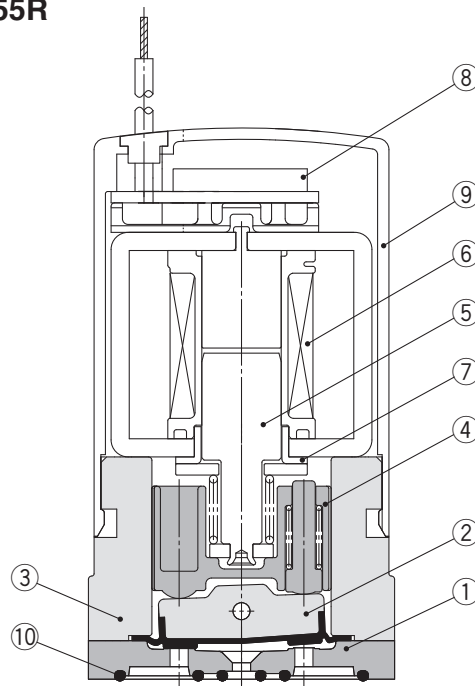

Component Parts: LVM15R3, 15R4, 15R6, 15R

No.	Description	Material
1	Plate	PEEK
2	Diaphragm assembly	EPDM/FKM/Kalrez®
3	Body	PBT
4	Slide bushing assembly	PPS/Stainless steel
5	Armature assembly	—
6	Coil assembly	—
7	Sleeve	SUY (Iron)
8	Board assembly	—
9	Casing	PBT
10	Interface gasket	EPDM/FKM/Kalrez®

* Kalrez® is a registered trademark of E. I. du Pont de Nemours and Company or its affiliates.

LVM07

LVM09/090

LVM10/100

LVM15/150

LVM20/200

LVM11/13

Specific Product Precautions

Spare Parts

LVM15/150 Series



Dimensions

Base mounted, Without sub-plate

LVM15R3-□□-□ (N.C.)

LVM15R4-□□-□ (N.O.)

LVM15R6-□□-□ (N.C.)

LVM155R-□□-□ (Universal)

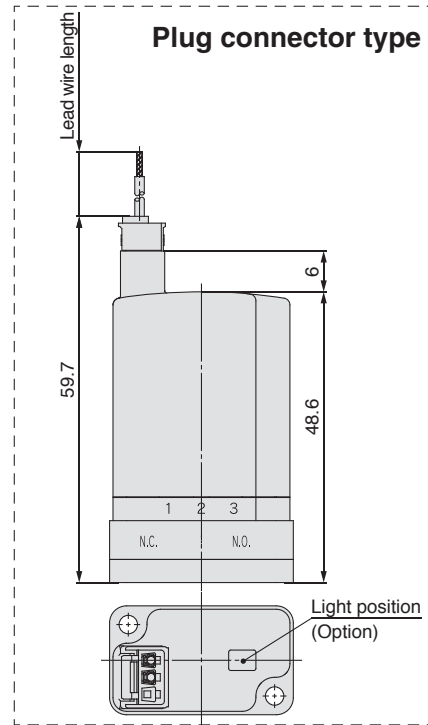
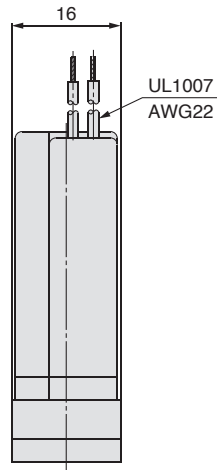
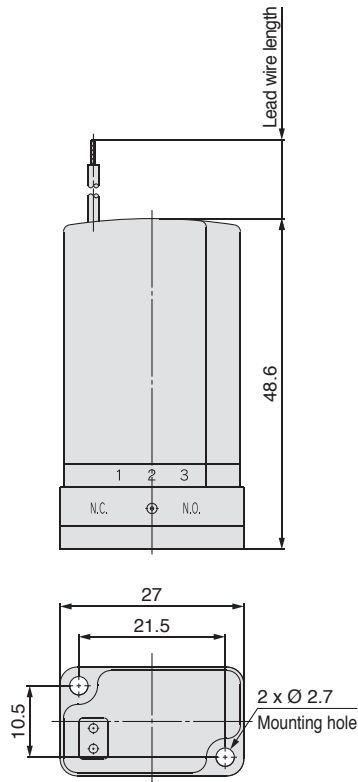

Ø 1.4 depth 2.3
For Option "P"
(With reverse mounting
prevention pin):
Ø 2, height 2

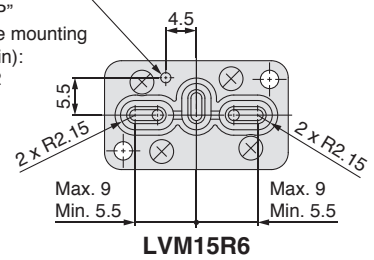

LVM15R6

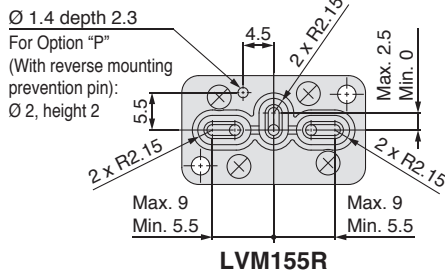

LVM155R

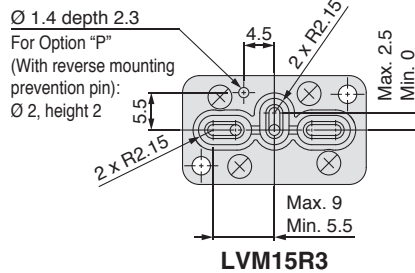

LVM15R3

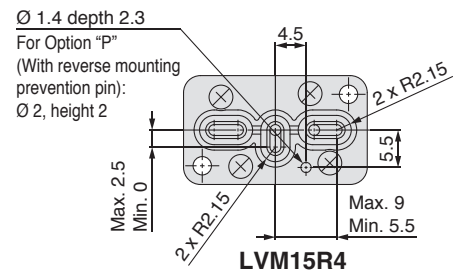

LVM15R4

Recommended interface dimensions * Surface roughness = Rz3.2 or less

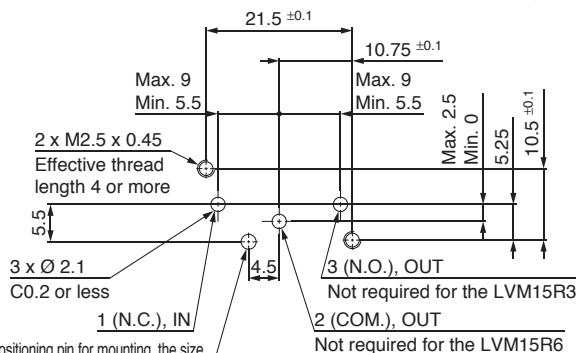

When using a positioning pin for mounting, the size should be Ø 1.2, and the height should be 2 or less.
For Option "P" (With reverse mounting prevention pin), the size should be Ø 2.2, and the depth should be 2.3 or more.

LVM15R3, 15R6, 155R

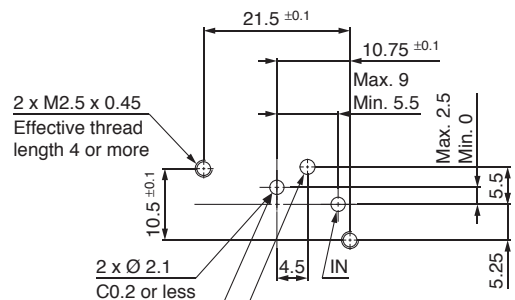

When using a positioning pin for mounting, the size should be Ø 1.2, and the height should be 2 or less.
For Option "P" (With reverse mounting prevention pin), the size should be Ø 2.2, and the depth should be 2.3 or more.

LVM15R4



Dimensions

Base mounted, With sub-plate

LVM15R3-□□□-□ (N.C.)

LVM15R4-□□□-□ (N.O.)

LVM15R6-□□□-□ (N.C.)

LVM155R-□□□-□ (Universal)

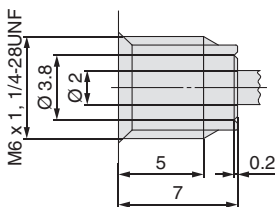
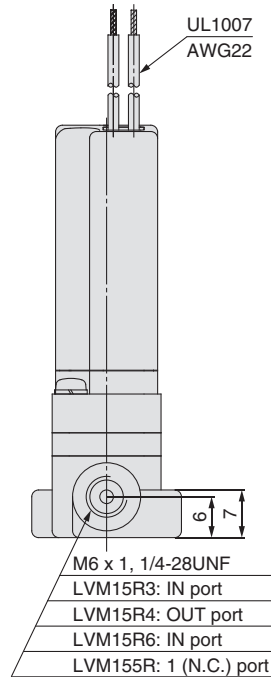
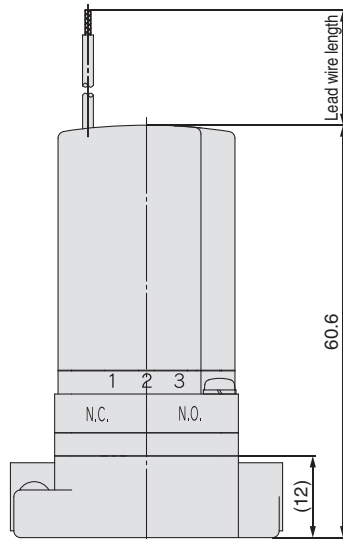
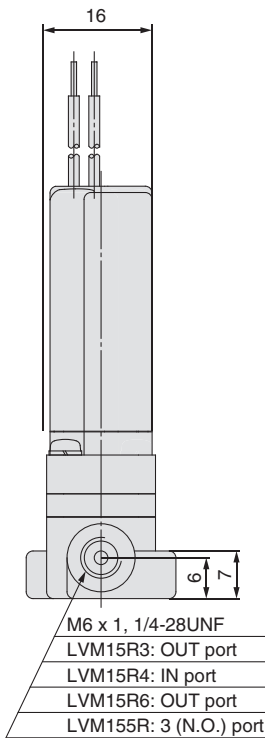
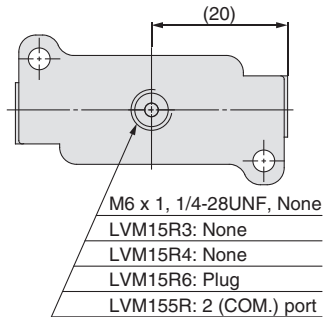
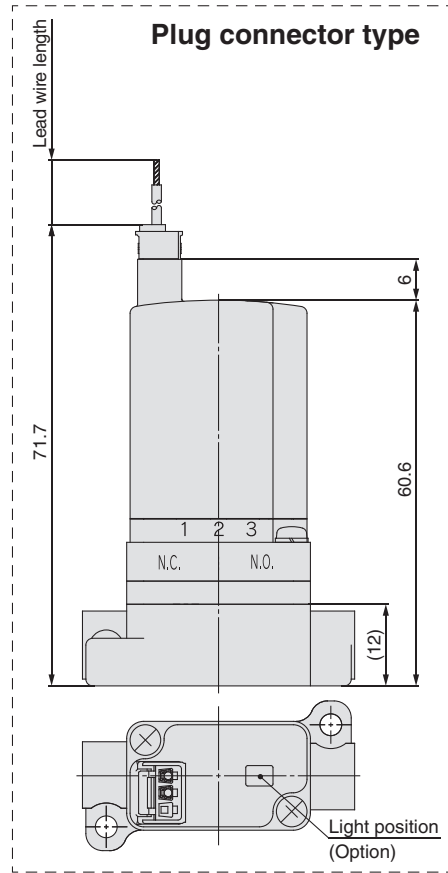

Details of thread

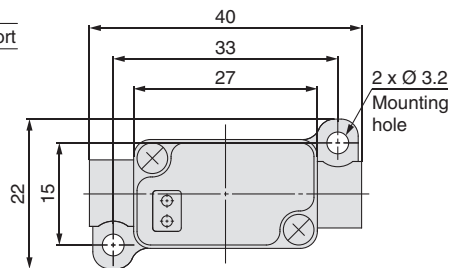

LVM07

LVM09/090

LVM10/100

LVM15/150

LVM20/200

LVM11/13

Specific Product Precautions

Spare Parts

Direct Operated Rocker Type



Compact Direct Operated 2/3-Port Solenoid Valve for Chemical Liquids

LVM20/200 Series

How to Order

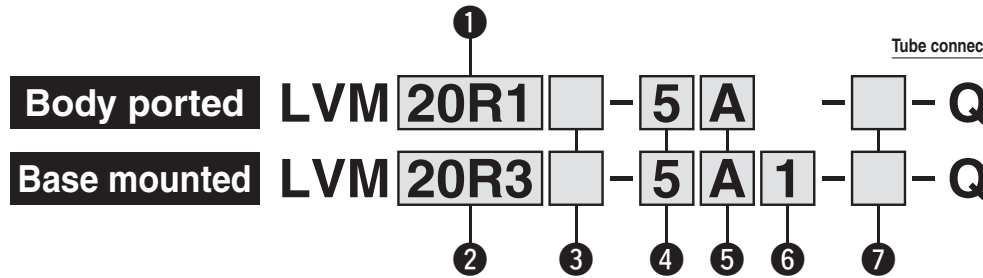
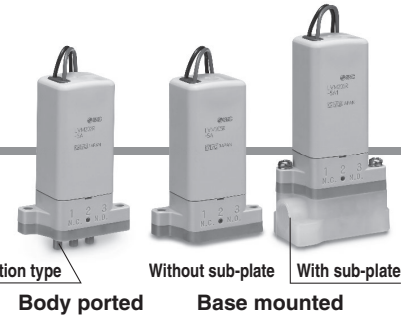

① Number of ports, Valve type

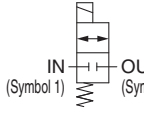
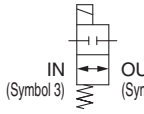
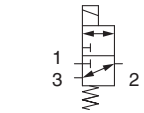
Symbol	Number of ports	Valve type
20R1	2	N.C. 
20R2		N.O. 
202R	3	Universal 

② Number of ports, Valve type

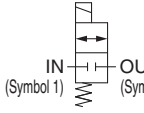
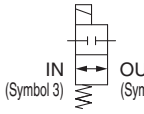
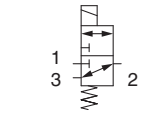
Symbol	Number of ports	Valve type
20R3	2	N.C. 
20R4		N.O. 
205R	3	Universal 

③ Power saving circuit

—	None (Standard type)
Y	Yes

④ Coil voltage

Symbol	Voltage
5	24 VDC
6	12 VDC

⑤ Fluid contact material

Symbol	Plate	Diaphragm
A	PEEK	EPDM
B	PEEK	FKM
C	PEEK	Kalrez®

⑥ Sub-plate material/port size, Reverse mounting prevention pin

Symbol	Sub-plate		Reverse mounting prevention pin	
	Material	Port size		
—	None		None	
P			Yes	
1			Rc1/8	None
1F			G1/8	
1N	NPT1/8			

* A sub-plate cannot be mounted for "P" (With reverse mounting prevention pin).

⑦ Electrical entry, Lead wire length, Light/surge voltage suppressor

Symbol	Electrical entry, Lead wire length	Light/surge voltage suppressor
—	Grommet, 300 mm	Cannot be selected
6	Grommet, 600 mm	
10	Grommet, 1000 mm	
K	Plug connector, 300 mm	None
KO	Plug connector, Without connector	
KZ	Plug connector, 300 mm	Yes * Power saving circuit "Y" is equipped with a light/surge voltage suppressor.
KOZ	Plug connector, Without connector	

* The plug connector is included but does not come assembled.

* If a lead wire length of 600 mm or more is required, select "KO□" (Without connector) and then add the connector part number shown below under the valve part number when ordering.

Plug connector part no.: AXT661 - 14A -

Lead wire length

6	600 mm
10	1000 mm
20	2000 mm
30	3000 mm

Mounting screws are included with the base-mounted type. (2 pcs.)
M3 x 14/With spring washer (Material: Stainless steel)

For other spare parts, refer to page 44.

* Kalrez® is a registered trademark of E. I. du Pont de Nemours and Company or its affiliates.

Specifications

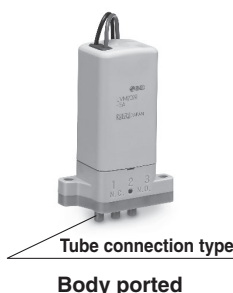

Model	Body ported (Tube connection type)			Base mounted		
	LVM20R1	LVM20R2	LVM20R	LVM20R3	LVM20R4	LVM20R5
Valve construction	Direct operated rocker type					
Valve type	N.C.	N.O.	Universal	N.C.	N.O.	Universal
Number of ports	2		3	2		3
Fluid*1	Air, Water, DI water (Pure water), Diluent, or Cleaning fluid					
Operating pressure range	-75 kPa to 0.25 MPa			-75 kPa to 0.3 MPa		
Orifice diameter	2 mm					
Response time*7	20 ms or less (at pneumatic pressure)					
Leakage	Zero leakage, both internal or external (at water pressure)					
Proof pressure*2	0.38 MPa			0.45 MPa		
Ambient temperature*8	0 to 50 °C					
Fluid temperature*8	0 to 50 °C (No freezing)					
Volume of valve chamber*3	84 μL					
Mounting orientation*4	Free					
Enclosure	IP40 or equivalent					
Weight	80 g			80 g (Without sub-plate), 94 g (With sub-plate)		
Rated voltage	12, 24 VDC					
Allowable voltage fluctuation*5	±10 % of rated voltage					
Type of coil insulation	Class B					
Power consumption (When rated voltage is at 24 V)	Standard type		2.5 W (0.1 A)			
	With power saving circuit	Inrush	4 W (0.17 A)			
		Holding	0.6 W			
Coil switching noise*6	60 dB					

- *1 Select an appropriate fluid contact material according to the fluid to be used. Additionally, check the chemical resistance beforehand.
- *2 Indicates the pressure which does not generate breakage or cracks after a one-minute airtight test
- *3 Indicates the volume of clearance inside the valve chamber after the volume of the diaphragm is subtracted
- *4 Since the body (orifice shape) is designed to eliminate residual liquid, mounting in a vertical direction with the coil at the top is recommended. When residual liquid need not be taken into consideration, any mounting orientation is available.
- *5 When response time is prioritized, control the voltage so that there is no fluctuation below the rated voltage.
- *6 The value is based on SMC's measurement conditions. The noise level will vary according to the actual conditions.
- *7 In compliance with JIS B 8419:2010
(Value at ambient and fluid temperatures of 25 °C, rated voltage, max. operating pressure (air), and when the N.C. (IN) port is pressurised)
The response time will vary depending on the supply pressure, fluid, piping conditions, and ambient temperature.
- *8 When the diaphragm material is Kalrez®, the valve changeover time will be significantly longer at ambient and fluid temperatures of 15 °C or less when compared to the valve changeover time at room temperature (≈ 25 °C).
- * Refer to 10 in "Design / Selection" on page 41 if the valve is to be energized continuously for extended periods of time.

Flow Rate Characteristics

Water		Air	
Kv	Cv	C	b
0.055	0.065	0.23	0.27

* The values of Kv and Cv are based on JIS B 2005:1995; the values of C and b are based on JIS B 8390:2000.

* Kalrez® is a registered trademark of E. I. du Pont de Nemours and Company or its affiliates.

LVM20/200 Series

Construction

Body ported
LVM20R1

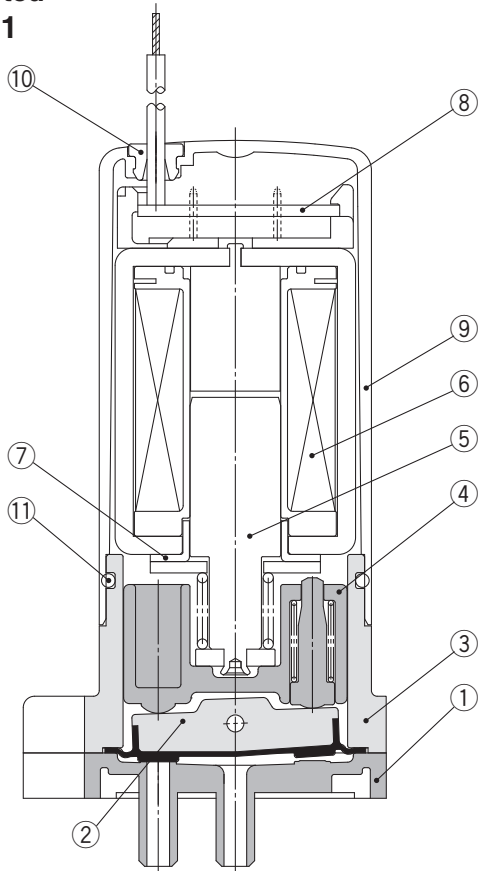

LVM20R2

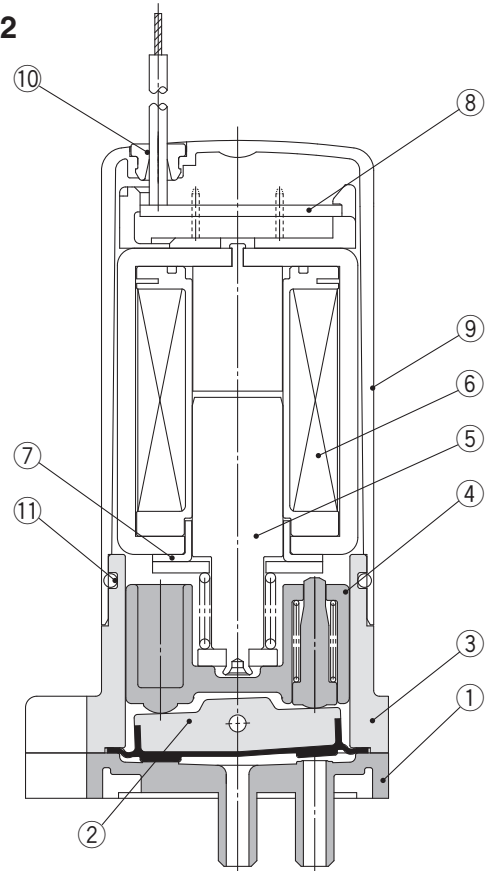

LVM202R

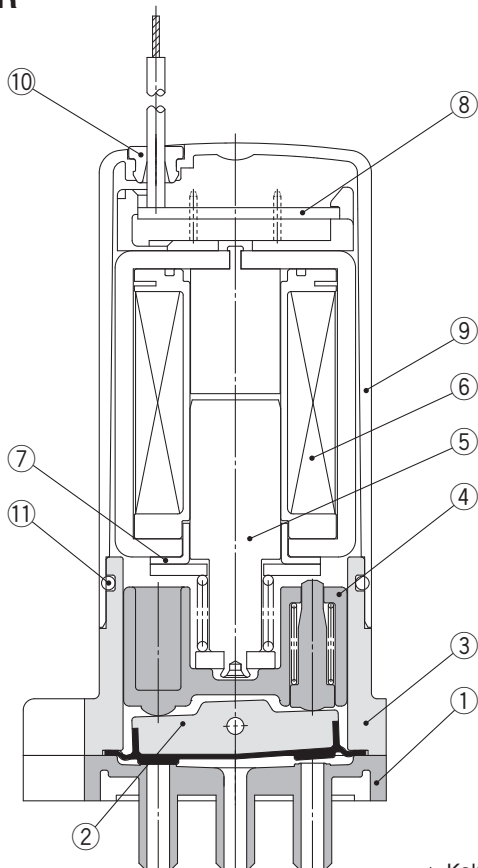

Component Parts: LVM20R1, 20R2, 202R

No.	Description	Material
1	Plate	PEEK
2	Diaphragm assembly	EPDM/FKM/Kalrez®
3	Body	PBT
4	Slide bushing assembly	PPS/Stainless steel
5	Armature assembly	—
6	Coil assembly	—
7	Sleeve	SUY (Iron)
8	Board assembly	—
9	Casing	PBT
10	Plug	NBR
11	O-ring	NBR

* Kalrez® is a registered trademark of E. I. du Pont de Nemours and Company or its affiliates.

Construction

Base mounted LVM20R3

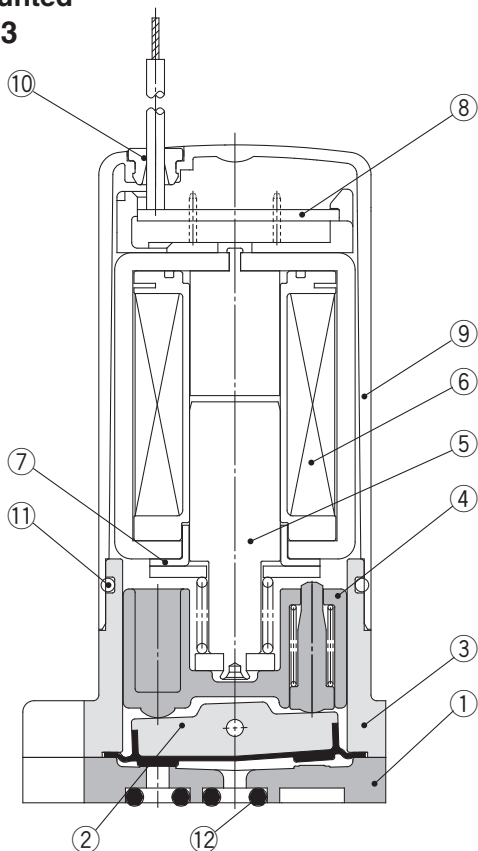

LVM20R4

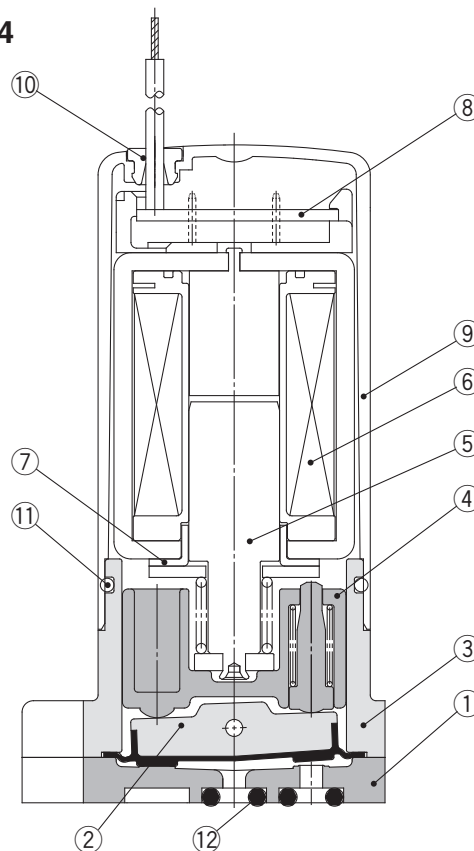

LVM205R

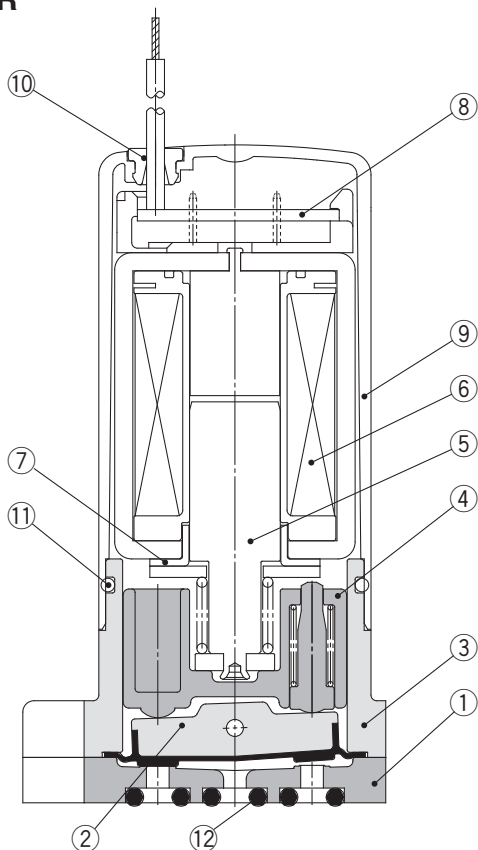

Component Parts: LVM20R3, 20R4, 205R

No.	Description	Material
1	Plate	PEEK
2	Diaphragm assembly	EPDM/FKM/Kalrez®
3	Body	PBT
4	Slide bushing assembly	PPS/Stainless steel
5	Armature assembly	—
6	Coil assembly	—
7	Sleeve	SUY (Iron)
8	Board assembly	—
9	Casing	PBT
10	Plug	NBR
11	O-ring	NBR
12	O-ring	EPDM/FKM/Kalrez®

* Kalrez® is a registered trademark of E. I. du Pont de Nemours and Company or its affiliates.

LVM07
 LVM09/090
 LVM10/100
 LVM15/150
 LVM20/200
 LVM11/13
 Specific Product Precautions
 Spare Parts

LVM20/200 Series

Dimensions

Body ported

LVM20R1-□□-□ (N.C.)

LVM20R2-□□-□ (N.O.)

LVM202R-□□-□ (Universal)

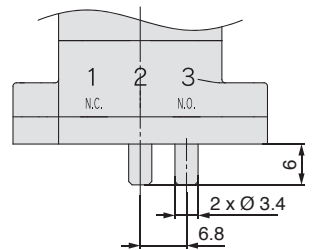
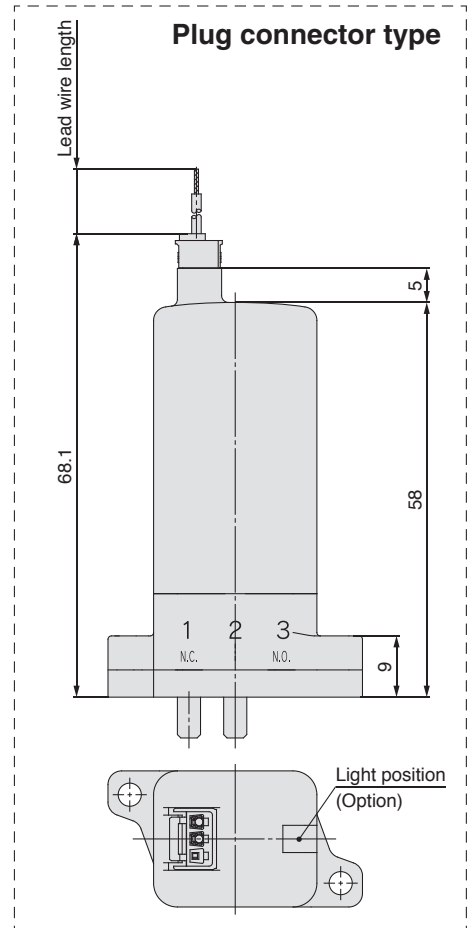
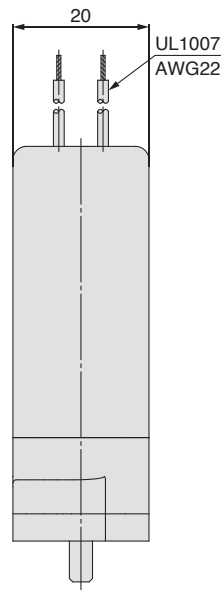
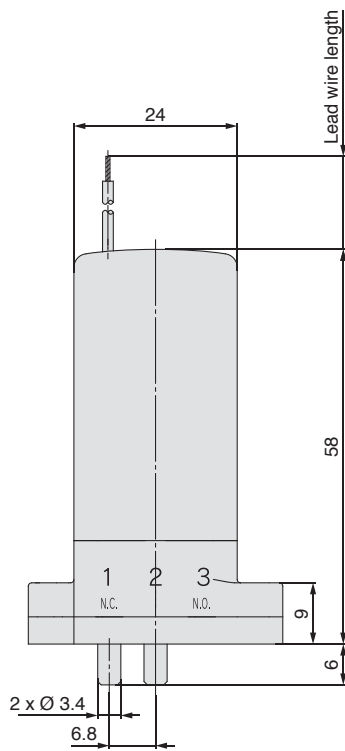

LVM20R2

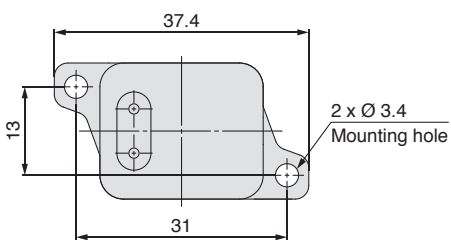

LVM20R1

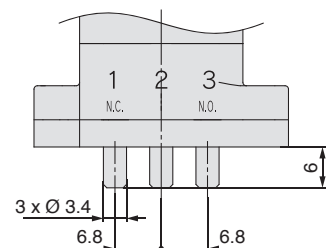

LVM202R

Dimensions

Base mounted, Without sub-plate

LVM20R3-□□-□ (N.C.)

LVM20R4-□□-□ (N.O.)

LVM205R-□□-□ (Universal)

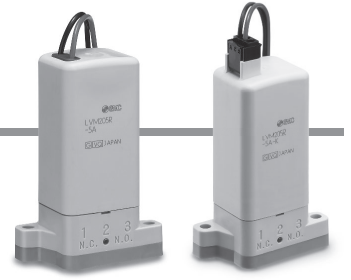

LVM07

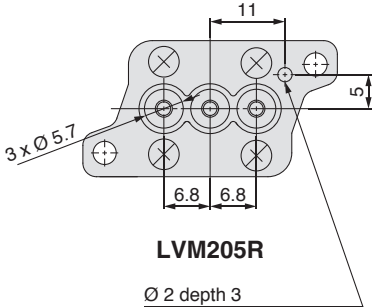

LVM205R

Ø 2 depth 3
For Option "P"
(With reverse mounting prevention pin):
Ø 2.5, height 2

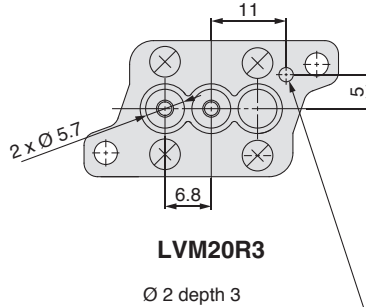

LVM20R3

Ø 2 depth 3
For Option "P"
(With reverse mounting prevention pin):
Ø 2.5, height 2

Ø 2 depth 3
For Option "P"
(With reverse mounting prevention pin):
Ø 2.5, height 2

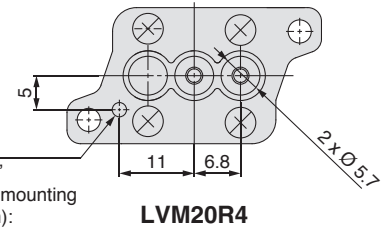

LVM20R4

LVM09/090

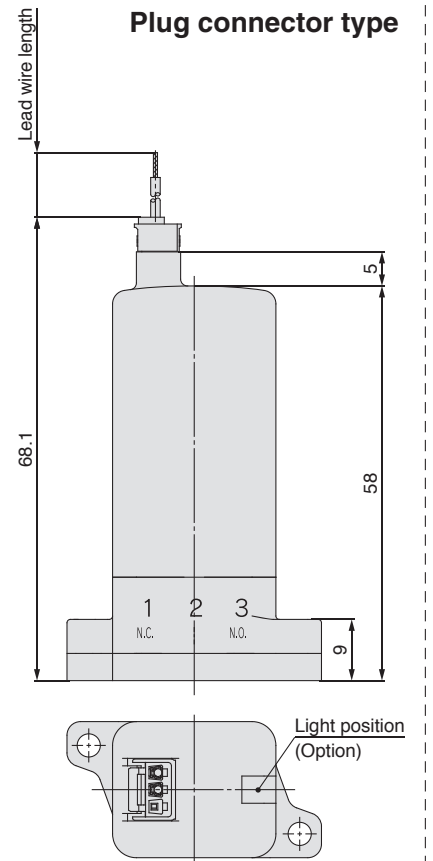
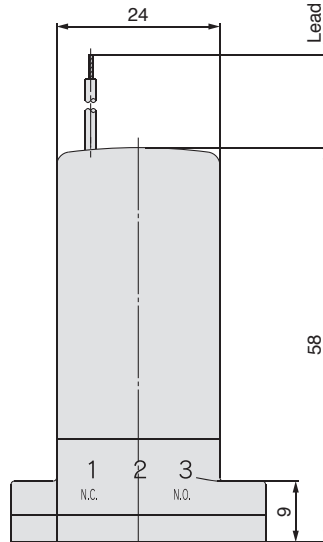
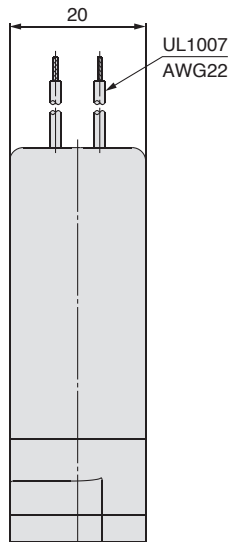

LVM10/100

LVM15/150

LVM20/200

LVM11/13

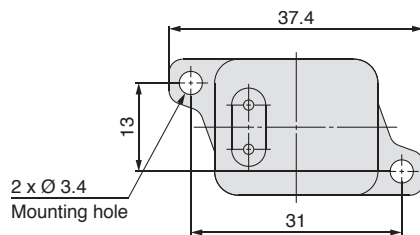

Recommended interface dimensions * Surface roughness = Rz3.2 or less

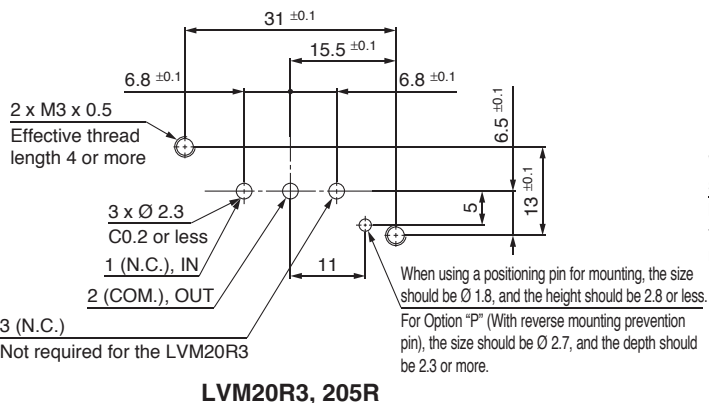

LVM20R3, 205R

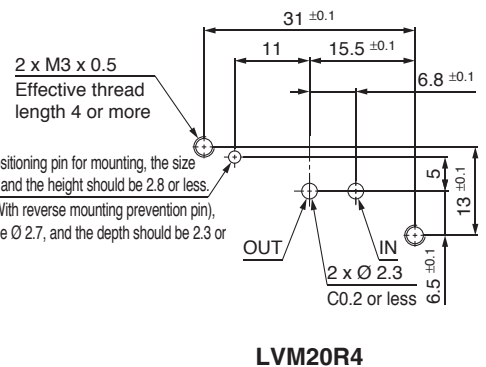

LVM20R4

Specific Product Precautions

Spare Parts

LVM20/200 Series



Dimensions

Base mounted, With sub-plate

LVM20R3-□□□-□ (N.C.)

LVM20R4-□□□-□ (N.O.)

LVM205R-□□□-□ (Universal)

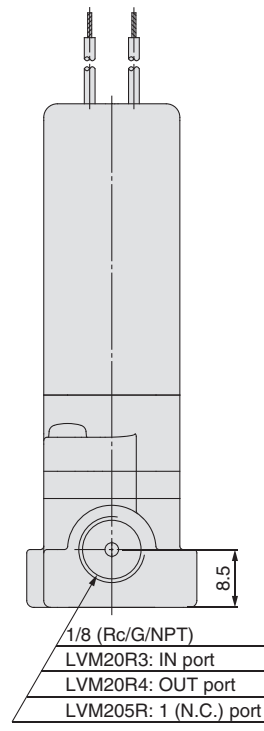
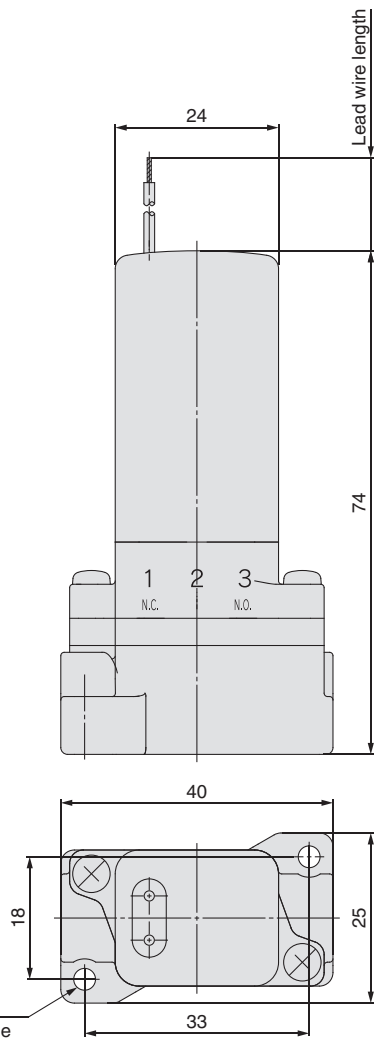
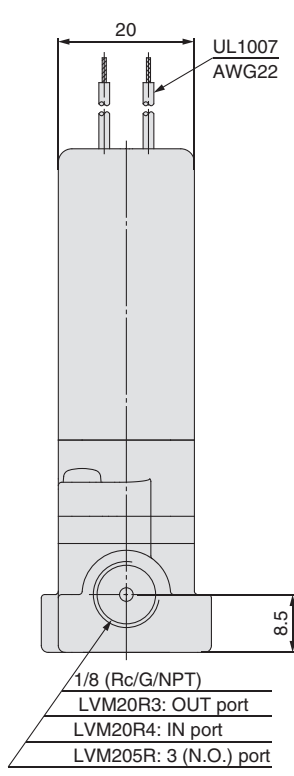
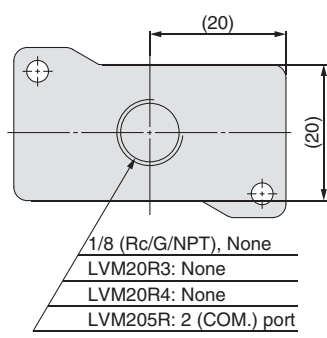
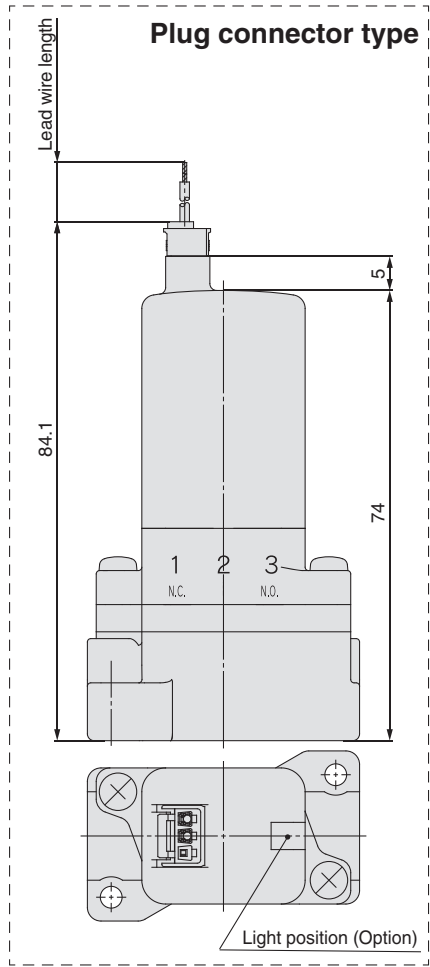

Compact Direct Operated
2/3-Port Solenoid Valve for Chemical Liquids with Power Saving Circuit

LVM11/13 Series

How to Order

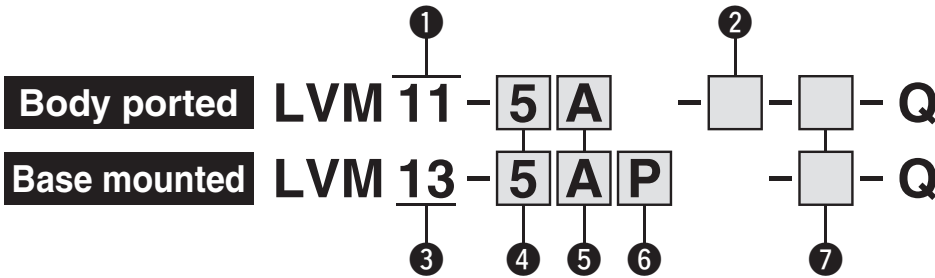
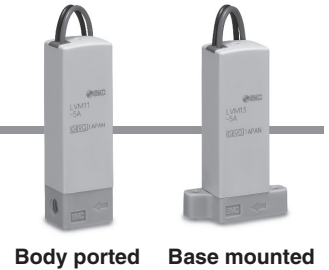

1 Number of ports, Valve type

Symbol	Number of ports	Valve type
11	2	N.C.

2 Option

—	None
1	Bracket

3 Number of ports, Valve type

Symbol	Number of ports	Valve type
13	2	N.C.

4 Coil voltage

Symbol	Voltage
5	24 VDC
6	12 VDC

5 Fluid contact material

Symbol	Body	Diaphragm
A	PEEK	EPDM
B	PEEK	FKM
C	PEEK	Kalrez®

6 Reverse mounting prevention pin

—	None
P	Yes

Reverse mounting prevention pin

7 Electrical entry, Lead wire length, Light/surge voltage suppressor

Symbol	Electrical entry, Lead wire length	Light/surge voltage suppressor
—	Grommet, 300 mm	Cannot be selected
6	Grommet, 600 mm	
10	Grommet, 1000 mm	
KZ	Plug connector, 300 mm	Yes
KOZ	Plug connector, Without connector	

* The plug connector is included but does not come assembled.

* If a lead wire length of 6 0 0 mm or more is required, select "KOZ" (Without connector) and then add the connector part number shown below under the valve part number when ordering.

Plug connector part no.: AXT661 - 14A - □

Lead wire length

6	600 mm
10	1000 mm
20	2000 mm
30	3000 mm

Mounting screws are included with the base-mounted type. (2 pcs.)
M2 x 11/With spring washer (Material: Stainless steel)

For other spare parts, refer to page 44.

* Kalrez® is a registered trademark of E. I. du Pont de Nemours and Company or its affiliates.

LVM11/13 Series

Specifications



Body ported



Base mounted

Model	Body ported	Base mounted	
	LVM11	LVM13	
Valve construction	Direct operated poppet type		
Valve type	N.C.		
Number of ports	2		
Fluid*1	Air, Water, DI water (Pure water), Diluent, or Cleaning fluid		
Operating pressure range	0 to 0.25 MPa		
Orifice diameter	1.5 mm		
Response time*7	10 ms or less (at pneumatic pressure)		
Leakage	Zero leakage, both internal or external (at water pressure)		
Proof pressure*2	0.38 MPa		
Ambient temperature*8	0 to 50 °C		
Fluid temperature*8	0 to 50 °C (No freezing)		
Volume of valve chamber*3	11 μL	13 μL	
Mounting orientation*4	Free		
Enclosure	IP40 or equivalent		
Weight	30 g		
Rated voltage	12, 24 VDC		
Allowable voltage fluctuation*5	±10 % of rated voltage		
Type of coil insulation	Class B		
Power consumption (When rated voltage is at 24 V)	With power saving circuit	Inrush	2.5 W (0.1 A)
		Holding	1 W
Coil switching noise*6	50 dB		

- *1 Select an appropriate fluid contact material according to the fluid to be used. Additionally, check the chemical resistance beforehand.
- *2 Indicates the pressure which does not generate breakage or cracks after a one-minute airtight test
- *3 Indicates the volume of clearance inside the valve chamber after the volume of the diaphragm is subtracted
- *4 Since the body (orifice shape) is designed to eliminate residual liquid, mounting in a vertical direction with the coil at the top is recommended. When residual liquid need not be taken into consideration, any mounting orientation is available.
- *5 When response time is prioritized, control the voltage so that there is no fluctuation below the rated voltage.
- *6 The value is based on SMC's measurement conditions. The noise level will vary according to the actual conditions.
- *7 In compliance with JIS B 8419:2010
(Value at ambient and fluid temperatures of 25 °C, rated voltage, max. operating pressure (air), and when the N.C. (IN) port is pressurised)
The response time will vary depending on the supply pressure, fluid, piping conditions, and ambient temperature.
- *8 When the diaphragm material is Kalrez®, the valve changeover time will be significantly longer at ambient and fluid temperatures of 15 °C or less when compared to the valve changeover time at room temperature (≈ 25 °C).
- * Refer to 10 in "Design / Selection" on page 41 if the valve is to be energized continuously for extended periods of time.

Flow Rate Characteristics

Water		Air	
Kv	Cv	C	b
0.034	0.04	0.13	0.22

* The values of Kv and Cv are based on JIS B 2005:1995; the values of C and b are based on JIS B 8390:2000.

* Kalrez® is a registered trademark of E. I. du Pont de Nemours and Company or its affiliates.

Construction

Body ported LVM11

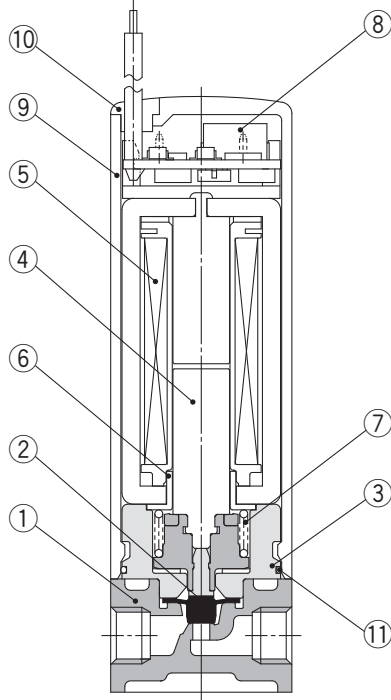

Component Parts: LVM11

No.	Description	Material
1	Body	PEEK
2	Diaphragm assembly	EPDM/FKM/Kalrez®
3	Spacer	PBT
4	Armature assembly	Stainless steel/POM
5	Coil assembly	—
6	Sleeve	SUY (Iron)
7	Return spring	Stainless steel
8	Board assembly	—
9	Casing	PBT
10	Plug	NBR
11	O-ring	NBR

Base mounted LVM13

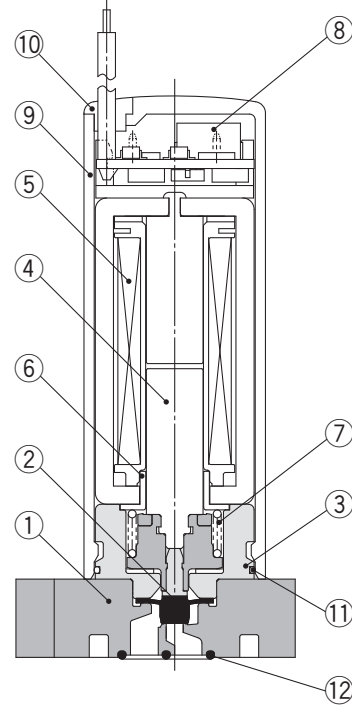

Component Parts: LVM13

No.	Description	Material
1	Body	PEEK
2	Diaphragm assembly	EPDM/FKM/Kalrez®
3	Spacer	PBT
4	Armature assembly	Stainless steel/POM
5	Coil assembly	—
6	Sleeve	SUY (Iron)
7	Return spring	Stainless steel
8	Board assembly	—
9	Casing	PBT
10	Plug	NBR
11	O-ring	NBR
12	Gasket	EPDM/FKM/Kalrez®

* Kalrez® is a registered trademark of E. I. du Pont de Nemours and Company or its affiliates.

LVM07

LVM09/090

LVM10/100

LVM15/150

LVM20/200

LVM11/13

Specific Product
Precautions

Spare Parts

LVM11/13 Series



Dimensions

Body ported

LVM11-□□-□ (N.C.)

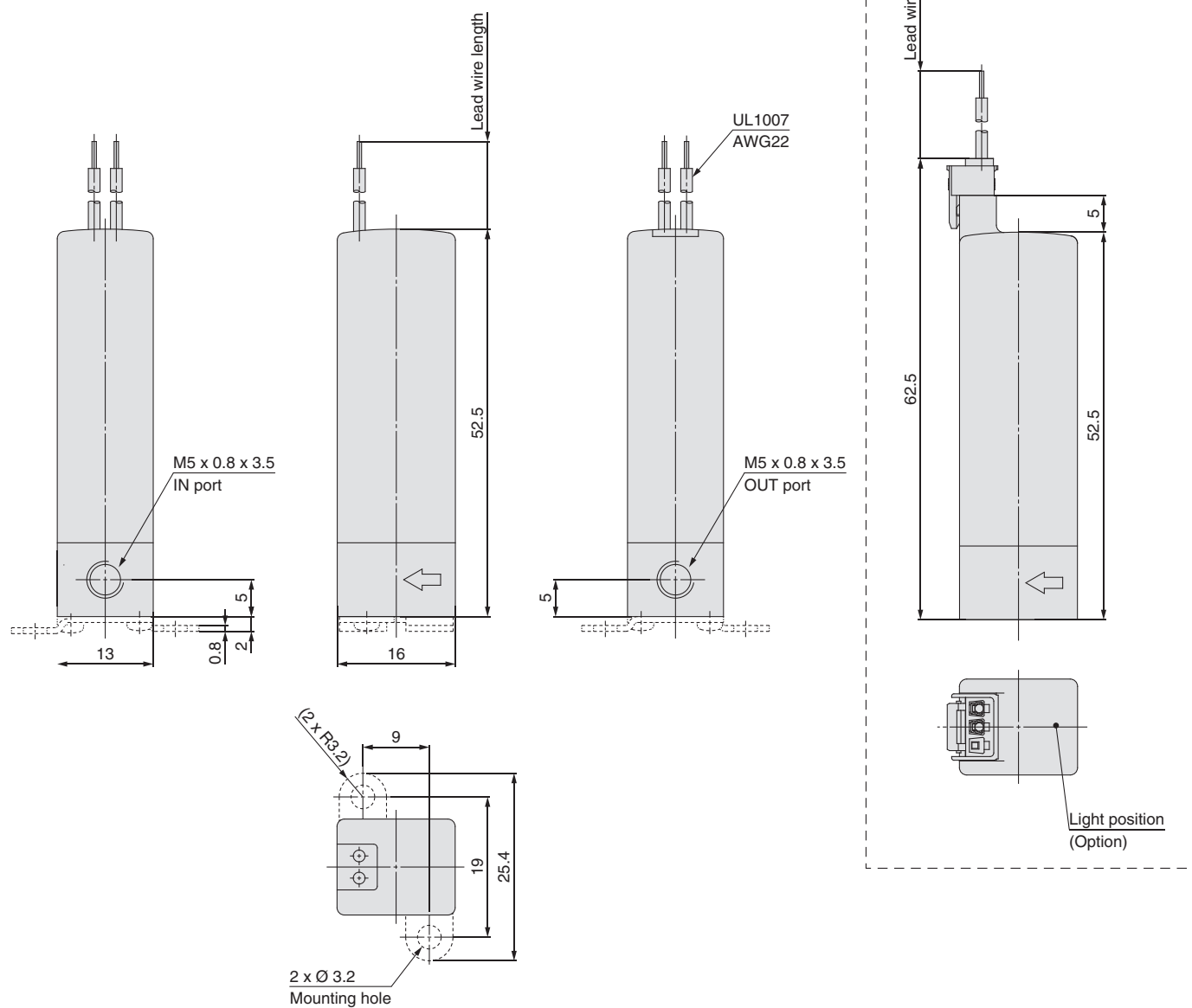



Dimensions

Base mounted
LVM13-□□-□ (N.C.)

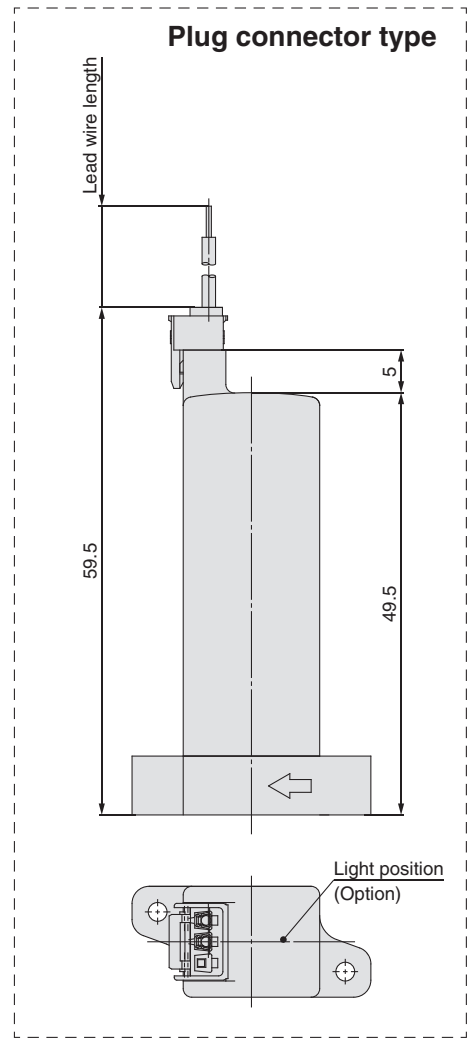
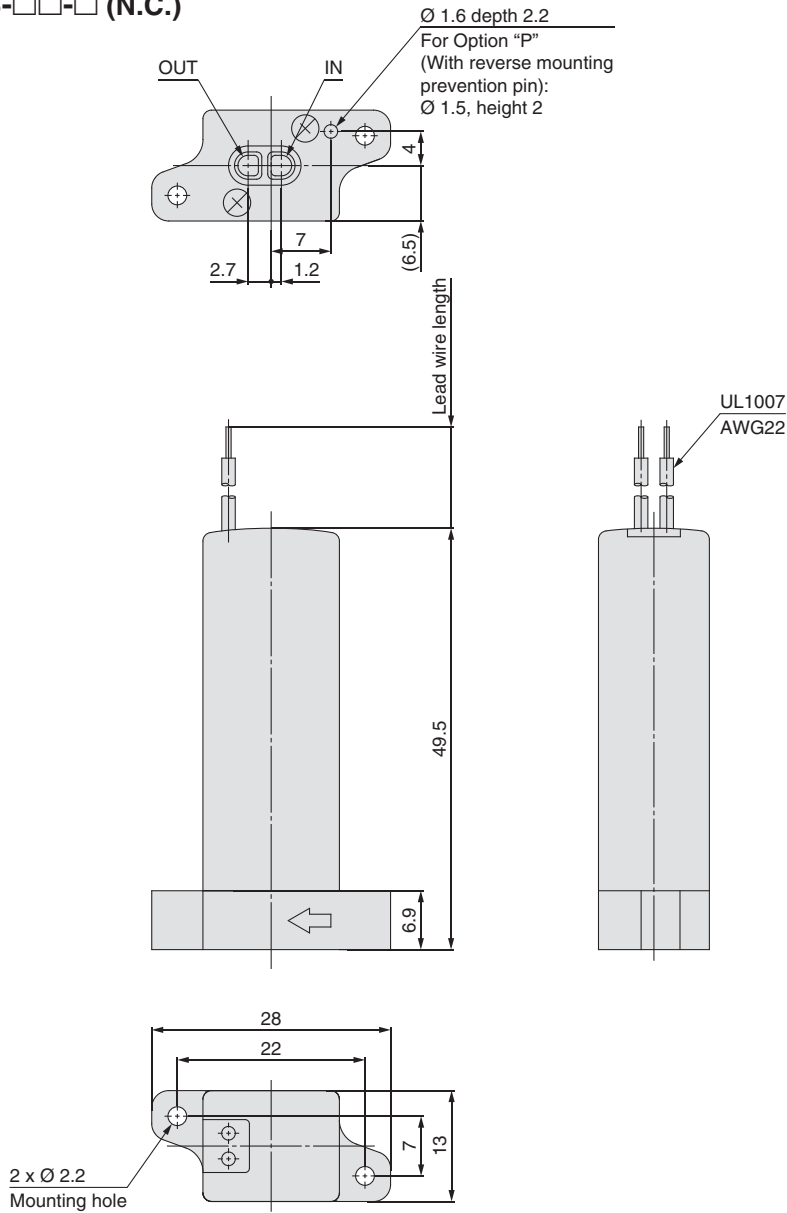

LVM07

LVM09/090

LVM10/100

LVM15/150

LVM20/200

LVM11/13

Specific Product Precautions

Spare Parts

Recommended interface dimensions * Surface roughness = Rz3.2 or less

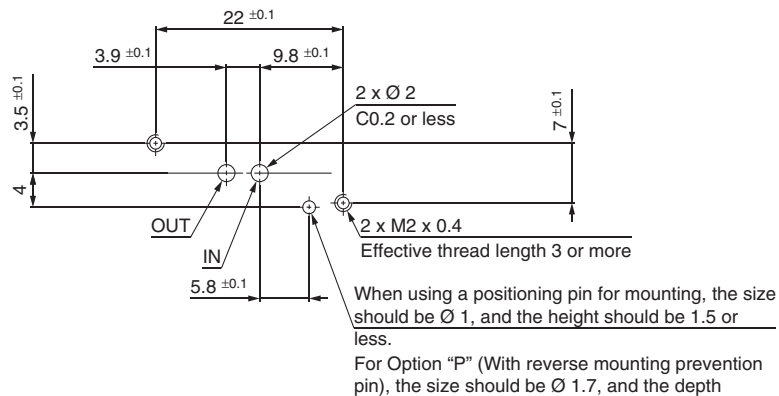



LVM Series

Specific Product Precautions 1

Be sure to read this before handling the products. Please contact SMC when it is used in conditions other than the specifications.

Design / Selection

Warning

1. Do not use this product in applications which may adversely affect human life (e.g. medical equipment connected to the human body for drip infusion).

2. Confirm the specifications.

Give careful consideration to the operating conditions, such as the application, fluid, and environment, and use within the specified operating ranges indicated in the catalogue.

3. Fluid

Be sure to confirm the compatibility between the component material and the fluid.

4. Ensure sufficient space for maintenance activities.

When installing the products, allow access for maintenance and inspection.

5. Fluid pressure range

Fluid pressure should be within the allowable pressure range.

6. Ambient environment

Use within the allowable ambient temperature range. Be sure that the liquid or corrosive gas does not touch the external surface of the product.

7. Countermeasures against static electricity

Take measures to prevent static electricity since some fluids can cause static electricity.

8. Pressure (including vacuum) holding

It is not usable for an application such as holding the pressure (including vacuum) inside of a pressure vessel because air leakage is entailed in a valve.

9. Cannot be used as an emergency shut-off valve, etc.

The valves presented in this catalogue are not designed for safety applications such as an emergency shut-off valve. If the valves are used in this type of system, other reliable safety assurance measures should also be adopted.

10. Extended periods of continuous energization

If solenoid valves are to be continuously energized for extended periods of time, use valves with power saving circuits to minimise the amount of heat released by the coil.

Power saving circuit waveform (example)

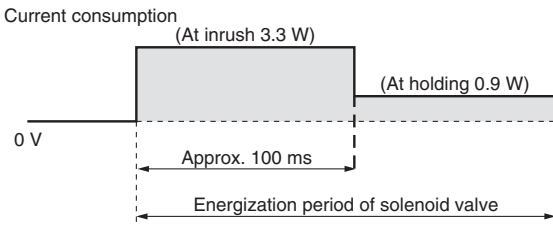

- * Power consumption for the waveform shown above is that of the LVM09/090.
- * For the LVM15/150, the type with power saving circuit is standard.
- * For the LVM10/100, the inrush is 50 ms.

When a solenoid valve without a power saving circuit is continuously energized for long periods of time, temperature increase from coil heat release can result in worsening performance and shortened service life of the solenoid valve, as well as adverse effects on peripheral equipment in the vicinity. For this reason, when valves are to be continuously energized for extended periods, use a fan or take other measures to disperse heat and keep valve surface temperatures at 70 °C or less.

The table below shows reference values for continuously energized valves (single unit) when surface temperature is 70 °C or less.

Model	LVM09/090	LVM10/100	LVM20/200
Period of continuous energization	5 min. or less	30 min. or less	30 min. or less
Duty ratio	50 % or less		
Ambient temperature	25 °C or less		
Power saving circuit	None		

* Duty ratio: ON time/(ON time + OFF time)

* For the LVM15/150, the type with power saving circuit is standard.

Please use a fan or take other measures to disperse heat and keep temperatures within the specified range when mounting the solenoid valves inside control panels, etc. Be especially careful when using three or more adjacent valves with manifolds and keeping them continuously energized for extended period, as this may result in dramatic increases in temperature.

11. Low temperature environments

Be aware that the valve changeover time becomes extremely long when the ambient and fluid temperature becomes 15 °C or less as a reference when compared to the valve changeover time at room temperature (approx. 25 °C).
Diaphragm material: Kalrez®

* Kalrez® is a registered trademark of E. I. du Pont de Nemours and Company or its affiliates.

Selection

Caution

1. Leakage voltage

The leakage voltage should be 2 % or less of the rated voltage. If the leakage voltage exceeds this value, solenoid valve may not turn OFF.

2. Valves with a power saving circuit (PWM circuit built-in type)

Valves with a power saving circuit (PWM circuit built-in type) perform the high-speed switching operation with the PWM control circuit inside the valve after the rated power has been applied for several tens of ms to reduce the power consumption. The problems shown below may occur in this type of valve due to the switch or drive circuit system by the PWM control. Be sure to check the operation with the customer's machine sufficiently when selecting the product.

1) The valve does not turn ON.

1. If the PWM circuit built-in type valve is driven by a mechanical relay, etc., and chattering occurs during the several tens of ms necessary for the valve to reach its rated voltage, the valve may not turn ON correctly.
2. If a filter, etc., is connected between the power supply and the PWM circuit built-in type valve, the current necessary to drive the valve lowers due to the effects of the filter, and then the valve may not turn ON correctly.

2) The valve does not turn OFF.

If the PWM circuit built-in type valve is driven by the photo coupler, the photo coupler cannot turn OFF and the valve is kept in an ON state. Therefore, take great care when using the photo coupler built-in SSR (solid state relay) or drive circuit.



LVM Series Specific Product Precautions 2

Be sure to read this before handling the products. Please contact SMC when it is used in conditions other than the specifications.

Mounting

⚠ Caution

1. Always tighten threads with the proper tightening torque.

When mounting the solenoid valve, tighten it with the proper tightening torque shown below.

Tightening Torque for Base Mounting

Location	Model	Thread size	Proper tightening torque [N·m]
Base mounted, Body mounting	LVM07R6	M1.6	0.06 to 0.1
	LVM09R3, 09R4, 09R6, 095R	M2	0.1 to 0.14
	LVM13	M2	0.15 to 0.2
	LVM10R3, 10R4, 10R6, 105R	M2	0.15 to 0.2
	LVM15R3, 15R4, 15R6, 155R	M2.5	0.25 to 0.35
	LVM20R3, 20R4, 205R	M3	0.4 to 0.6

2. Mount the solenoid valve on the horizontal surface.

Applicable model: All models

3. Remove dust from the solenoid valve mounting surface completely. The surface roughness of the mounting surface should be Rz3.2 or less.

Applicable model: Base mounted

4. When mounting the solenoid valves next to each other, the valve pitch should be the value or more shown in the table below.

Model	LVM07	LVM09/090	LVM13	LVM10/100	LVM15/150	LVM20/200
Valve pitch	8	10.5	14	14	17	21

Applicable model: All models

⚠ Warning

5. If air leakage increases or equipment does not operate properly, stop operation.

After mounting, perform suitable function and leak tests to confirm that the mounting is correct.

6. Since the body (orifice shape) is designed to eliminate residual liquid, mounting in a vertical direction with the coil at the top is recommended.

When residual liquid need not be taken into consideration, any mounting orientation is available.

Piping

⚠ Caution

1. Preparation before piping

Before piping is connected, it should be thoroughly blown out with air (flushing) or washed to remove chips, cutting oil, and other debris from inside the pipe.

2. When tubing is connected to the body-ported solenoid valve, insert the tubing straight to the end of the tube inlet for a complete fit.

Select appropriate tubing while referring to the table below.

Model	Tube inside diameter (I.D.)	Tubing outside diameter (O.D.) (after mounting)
LVM09R1, 09R2, 092R	Ø 1.9 or less	Ø 4.2 or less
LVM10R1, 10R2, 102R	Ø 2.5 or less	Ø 4.5 or less
LVM20R1, 20R2, 202R	Ø 3.1 or less	Ø 6.8 or less

The holding force varies by the tubing material. Be sure to confirm the holding force of each material before operation.

After connecting the tubing, care should be taken not to put excessive force (tensile force, compression, bending, etc.) on the tubing. If an external force of 20 N or more is applied to the tube inlet, the inlet may become damaged, and leakage or breakage could occur.

3. When the tubing is long or according to the operating conditions, tubing may thrash about, causing damage to the tube inlet of the solenoid valve, or the tubing to come off or deteriorate.

In this case, secure the tubing to prevent its uncontrolled movement.

4. When piping the fitting to the solenoid valve, the installation method and tightening torque value may vary depending on the seal structure (shape) or material of the fitting to be used. Check the methods and precautions recommended by the fitting manufacturer to be used, and be sure to check for leakage.

The table below shows the tightening method using the KQ2 series.

Model	Location	Thread size	Tightening method	Tightening torque [N·m] (Reference)
LVM11	Body	M5	After tightening by hand, tighten 1/6 to 1/4 turn with a tightening tool.	Material PEEK: 0.5 to 0.7
LVM10R3, 10R4, 10R6, 105R	Base mounted (With sub-plate)	M6 or 1/4-28UNF	After tightening by hand, tighten 1/6 to 1/4 turn with a tightening tool.	Material PVDF: 0.6 to 0.8 Material PFA: 0.2 to 0.25
LVM15R3, 15R4, 15R6, 155R		M6 or 1/4-28UNF	After tightening by hand, tighten 1/6 to 1/4 turn with a tightening tool.	Material PVDF: 0.6 to 0.8
LVM20R3, 20R4, 205R		Rc1/8 or NPT1/8	Tighten approximately 4 turns.	Material PVDF: 0.5 to 0.6
		G1/8	After tightening by hand, tighten 1/3 to 1/2 turn with a tightening tool.	Material PVDF: 0.4 to 0.6

LVM07

LVM09/090

LVM10/100

LVM15/150

LVM20/200

LVM11/13

Specific Product Precautions

Spare Parts



LVM Series

Specific Product Precautions 3

Be sure to read this before handling the products. Please contact SMC when it is used in conditions other than the specifications.

Wiring

⚠ Caution

1. Use electrical circuits which do not generate chattering in their contacts.
2. Use voltage which is within $\pm 10\%$ of the rated voltage.
However, when response time is prioritized, control the voltage so that there is no fluctuation below the rated voltage.
3. Apply the correct voltage.
Applying incorrect voltage may cause a malfunction or a burned coil.
4. Connect the wires so that an external force of 10 N or more is not applied to the lead wire.
Otherwise, the coil will burn.

5. Units with power saving circuits use polarized electrical connections.

Red (+), Black (-)

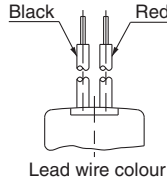

Fluid Properties

⚠ Warning

Liquid (chemicals)

Component crystallizes or clots depending on its nature. Leakage will occur when a crystallized or clotted component is caught between the sealing parts.

Take measures to clean such component if necessary.

Water

Install a filter strainer of about 100 mesh on the inlet side of the piping.

Air

Compressed air filtered with a filter with filtration rating of 5 μm or less, which is mounted on the inlet side of the piping, should be used.

Operating Environment

⚠ Warning

1. Do not use the product in a place where there is contact with corrosive gases, chemicals or liquids.
2. Do not use in explosive atmospheres.
3. Do not use in locations subject to excessive vibration or impact.
Impact resistance of this solenoid valve is 150 m/s^2 . Vibration resistance of this solenoid valve is 30 m/s^2 .
4. Do not use in locations where radiated heat will be received from nearby heat sources.

Maintenance

⚠ Warning

1. Removing the product

Shut off the fluid supply and release the fluid pressure in the system. Shut off the power supply. Remove the product.

2. Before operating, remove residual chemicals and completely replace it with pure water, air, etc.

3. Do not disassemble the product.

Products which have been disassembled cannot be guaranteed. If disassembly is necessary, please contact SMC.

How to Use Plug Connector

⚠ Caution

Attaching connectors

Hold the lever and connector unit between your fingers and insert straight onto the pins of the solenoid valve so that the lever's pawl is pushed into the groove and locks.

Detaching connectors

Remove the pawl from the groove by pushing the lever downward with your thumb, and pull the connector straight out.

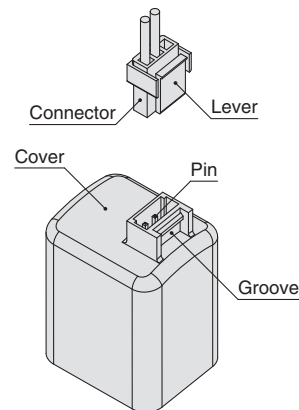

LVM Series Spare Parts

■ Mounting Screw (Base mounted, For Body mounting)

Applicable model	Part number	Qty.
LVM07R6	LVM070-SC	20
LVM09R3, 09R4, 09R6, 095R	LVM090-SC	20
LVM13	LVM100-SC	20
LVM10R3, 10R4, 10R6, 105R		
LVM15R3, 15R4, 15R6, 155R	LVM150-SC	20
LVM20R3, 20R4, 205R	LVM200-SC	20

■ Sub-plate (Base mounted, Option)

Applicable model	Part number	Qty.
LVM10R3, 10R4, 10R6 (Material: PVDF)	LVM100-S2-1-□	□: Port size M6: M6 x 1 28: 1/4-28UNF
LVM10R3, 10R4, 10R6 (Material: PFA)	LVM100-S2-2-□	
LVM105R (Material: PVDF)	LVM100-S1-1-□	□: Port size M6: M6 x 1 28: 1/4-28UNF
LVM105R (Material: PFA)	LVM100-S1-2-□	
LVM15R3, 15R4	LVM150-S2-1-□	□: Port size M6: M6 x 1 28: 1/4-28UNF
LVM15R6	LVM150-S6-1-□	
LVM155R	LVM150-S1-1-□	
LVM20R3, 20R4	LVM200-S2-1-□	□: Port size O1: Rc1/8 F1: G1/8 N1: NPT1/8
LVM205R	LVM200-S1-1-□	

■ Gasket, O-ring (Base mounted, For Interface mounting)

Applicable model	Part number	Qty.
LVM07R6	LVM070-GS-□	□: Material A: EPDM B: FKM C: Kalrez®
LVM09R3, 09R4, 09R6, 095R	LVM090-GS-□	
LVM13	LVM13-GS-□	
LVM10R3, 10R4, 10R6, 105R	LVM100-OR-□	
LVM15R3, 15R4, 15R6, 155R	LVM150-GS-□	
LVM20R3, 20R4, 205R	LVM200-OR-□	

■ Bracket (Option)

Applicable model	Part number	Qty.	Note
LVM11	LVM10-14A-1	1	With mounting screws
LVM10R1, 10R2, 102R	LVM100-10A-1	1	
LVM10R3, 10R4, 10R6, 105R	LVM100-18A-1	1	



■ Plug Connector

Applicable model	Part number	Qty.
LVM09/090	SY100-30-4A-□	□: Lead wire length —: 300 mm 6: 600 mm 10: 1000 mm 30: 3000 mm
LVM11/13/10/100/15/150/20/200	AXT661-14A-□	

* Kalrez® is a registered trademark of E. I. du Pont de Nemours and Company or its affiliates.

Safety Instructions

These safety instructions are intended to prevent hazardous situations and/or equipment damage. These instructions indicate the level of potential hazard with the labels of “Caution,” “Warning” or “Danger.” They are all important notes for safety and must be followed in addition to International Standards (ISO/IEC)¹⁾, and other safety regulations.

-  **Caution:** **Caution** indicates a hazard with a low level of risk which, if not avoided, could result in minor or moderate injury.
-  **Warning:** **Warning** indicates a hazard with a medium level of risk which, if not avoided, could result in death or serious injury.
-  **Danger:** **Danger** indicates a hazard with a high level of risk which, if not avoided, will result in death or serious injury.

- 1) ISO 4414: Pneumatic fluid power – General rules relating to systems.
ISO 4413: Hydraulic fluid power – General rules relating to systems.
IEC 60204-1: Safety of machinery – Electrical equipment of machines.
(Part 1: General requirements)
- ISO 10218-1: Manipulating industrial robots - Safety.
etc.

Warning

1. The compatibility of the product is the responsibility of the person who designs the equipment or decides its specifications.

Since the product specified here is used under various operating conditions, its compatibility with specific equipment must be decided by the person who designs the equipment or decides its specifications based on necessary analysis and test results. The expected performance and safety assurance of the equipment will be the responsibility of the person who has determined its compatibility with the product. This person should also continuously review all specifications of the product referring to its latest catalogue information, with a view to giving due consideration to any possibility of equipment failure when configuring the equipment.

2. Only personnel with appropriate training should operate machinery and equipment.

The product specified here may become unsafe if handled incorrectly. The assembly, operation and maintenance of machines or equipment including our products must be performed by an operator who is appropriately trained and experienced.

3. Do not service or attempt to remove product and machinery/equipment until safety is confirmed.

1. The inspection and maintenance of machinery/equipment should only be performed after measures to prevent falling or runaway of the driven objects have been confirmed.
2. When the product is to be removed, confirm that the safety measures as mentioned above are implemented and the power from any appropriate source is cut, and read and understand the specific product precautions of all relevant products carefully.
3. Before machinery/equipment is restarted, take measures to prevent unexpected operation and malfunction.

4. Contact SMC beforehand and take special consideration of safety measures if the product is to be used in any of the following conditions.

1. Conditions and environments outside of the given specifications, or use outdoors or in a place exposed to direct sunlight.
2. Installation on equipment in conjunction with atomic energy, railways, air navigation, space, shipping, vehicles, military, medical treatment, combustion and recreation, or equipment in contact with food and beverages, emergency stop circuits, clutch and brake circuits in press applications, safety equipment or other applications unsuitable for the standard specifications described in the product catalogue.
3. An application which could have negative effects on people, property, or animals requiring special safety analysis.
4. Use in an interlock circuit, which requires the provision of double interlock for possible failure by using a mechanical protective function, and periodical checks to confirm proper operation.

Caution

1. The product is provided for use in manufacturing industries.

The product herein described is basically provided for peaceful use in manufacturing industries. If considering using the product in other industries, consult SMC beforehand and exchange specifications or a contract if necessary. If anything is unclear, contact your nearest sales branch.

Limited warranty and Disclaimer/Compliance Requirements

The product used is subject to the following “Limited warranty and Disclaimer” and “Compliance Requirements”. Read and accept them before using the product.

Limited warranty and Disclaimer

1. The warranty period of the product is 1 year in service or 1.5 years after the product is delivered, whichever is first.²⁾ Also, the product may have specified durability, running distance or replacement parts. Please consult your nearest sales branch.
 2. For any failure or damage reported within the warranty period which is clearly our responsibility, a replacement product or necessary parts will be provided. This limited warranty applies only to our product independently, and not to any other damage incurred due to the failure of the product.
 3. Prior to using SMC products, please read and understand the warranty terms and disclaimers noted in the specified catalogue for the particular products.
- 2) Vacuum pads are excluded from this 1 year warranty.
A vacuum pad is a consumable part, so it is warranted for a year after it is delivered. Also, even within the warranty period, the wear of a product due to the use of the vacuum pad or failure due to the deterioration of rubber material are not covered by the limited warranty.

Compliance Requirements

1. The use of SMC products with production equipment for the manufacture of weapons of mass destruction (WMD) or any other weapon is strictly prohibited.
2. The exports of SMC products or technology from one country to another are governed by the relevant security laws and regulations of the countries involved in the transaction. Prior to the shipment of a SMC product to another country, assure that all local rules governing that export are known and followed.

Caution

SMC products are not intended for use as instruments for legal metrology.

Measurement instruments that SMC manufactures or sells have not been qualified by type approval tests relevant to the metrology (measurement) laws of each country. Therefore, SMC products cannot be used for business or certification ordained by the metrology (measurement) laws of each country.

Safety Instructions

Be sure to read “Handling Precautions for SMC Products” (M-E03-3) before using.

Revision History

Edition C	<ul style="list-style-type: none">- The LVM07 series has been added.- The body-ported type and new variations have been added to the LVM09 series.- New variations have been added to the LVM15 series.- Various options have been added.- Number of pages has been increased from 28 to 48.	YU
------------------	--	----

SMC Corporation (Europe)

Austria	+43 (0)2262622800	www.smc.at	office@smc.at
Belgium	+32 (0)33551464	www.smc.be	info@smc.be
Bulgaria	+359 (0)2807670	www.smc.bg	office@smc.bg
Croatia	+385 (0)13707288	www.smc.hr	office@smc.hr
Czech Republic	+420 541424611	www.smc.cz	office@smc.cz
Denmark	+45 70252900	www.smc.dk.com	smc@smcdk.com
Estonia	+372 6510370	www.smc.pneumatics.ee	info@smcee.ee
Finland	+358 207513513	www.smc.fi	smc.fi@smc.fi
France	+33 (0)164761000	www.smc-france.fr	info@smc-france.fr
Germany	+49 (0)61034020	www.smc.de	info@smc.de
Greece	+30 210 2717265	www.smchellas.gr	sales@smchellas.gr
Hungary	+36 23513000	www.smc.hu	office@smc.hu
Ireland	+353 (0)14039000	www.smcautomation.ie	sales@smcautomation.ie
Italy	+39 03990691	www.smcitalia.it	mailbox@smcitalia.it
Latvia	+371 67817700	www.smc.lv	info@smc.lv

Lithuania	+370 5 2308118	www.smclt.lt	info@smclt.lt
Netherlands	+31 (0)205318888	www.smc.nl	info@smc.nl
Norway	+47 67129020	www.smc-norge.no	post@smc-norge.no
Poland	+48 222119600	www.smc.pl	office@smc.pl
Portugal	+351 214724500	www.smc.eu	apoioclientept@smc.smces.es
Romania	+40 213205111	www.smcromania.ro	smcromania@smcromania.ro
Russia	+7 8123036600	www.smc.eu	sales@smcru.com
Slovakia	+421 (0)413213212	www.smc.sk	office@smc.sk
Slovenia	+386 (0)73885412	www.smc.si	office@smc.si
Spain	+34 945184100	www.smc.eu	post@smc.smces.es
Sweden	+46 (0)86031200	www.smc.nu	smc@smc.nu
Switzerland	+41 (0)523963131	www.smc.ch	helpcentre@smc.ch
Turkey	+90 212 489 0 440	www.smc.pnomatik.com.tr	info@smcpnomatik.com.tr
UK	+44 (0)845 121 5122	www.smc.uk	sales@smc.uk