

VXB, Air Operated, Angle Seat Valve VXB215BHA

Datasheet

General series information

- For steam (can also be used with air and water)
- Low pressure loss due to angle seat structure
- Low leakage of 10 cm³/min or less (rubber seal)
- Long service life: 3 million cycles (steam) 5 million cycles (air)
- Body material: stainless steel 316L equivalent, bronze (CAC)

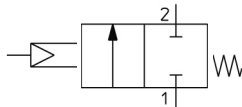

Directional control valve 2/2-way valve, closed normal position With pressure control Return with mechanical control spring

Standard specifications

Body material/Port size/Orifice diameter	B (Bronze, 1/2, 14)
Pressure Type	H (High Pressure)
Thread Type	A (G)
Indicator	No
Special Option	None
Maximum temperature of pressure medium	183 °C
Maximum operating pressure	1.2 MPa
Proof pressure	2.4 MPa
Maximum ambient temperature	60 °C; 60 °C
Minimum ambient temperature	-20 °C; -20 °C
Pneumatic input connection	G 1/8
Orifice diameter	Ø14 mm
Weight	0.602 Kg

Dimensions

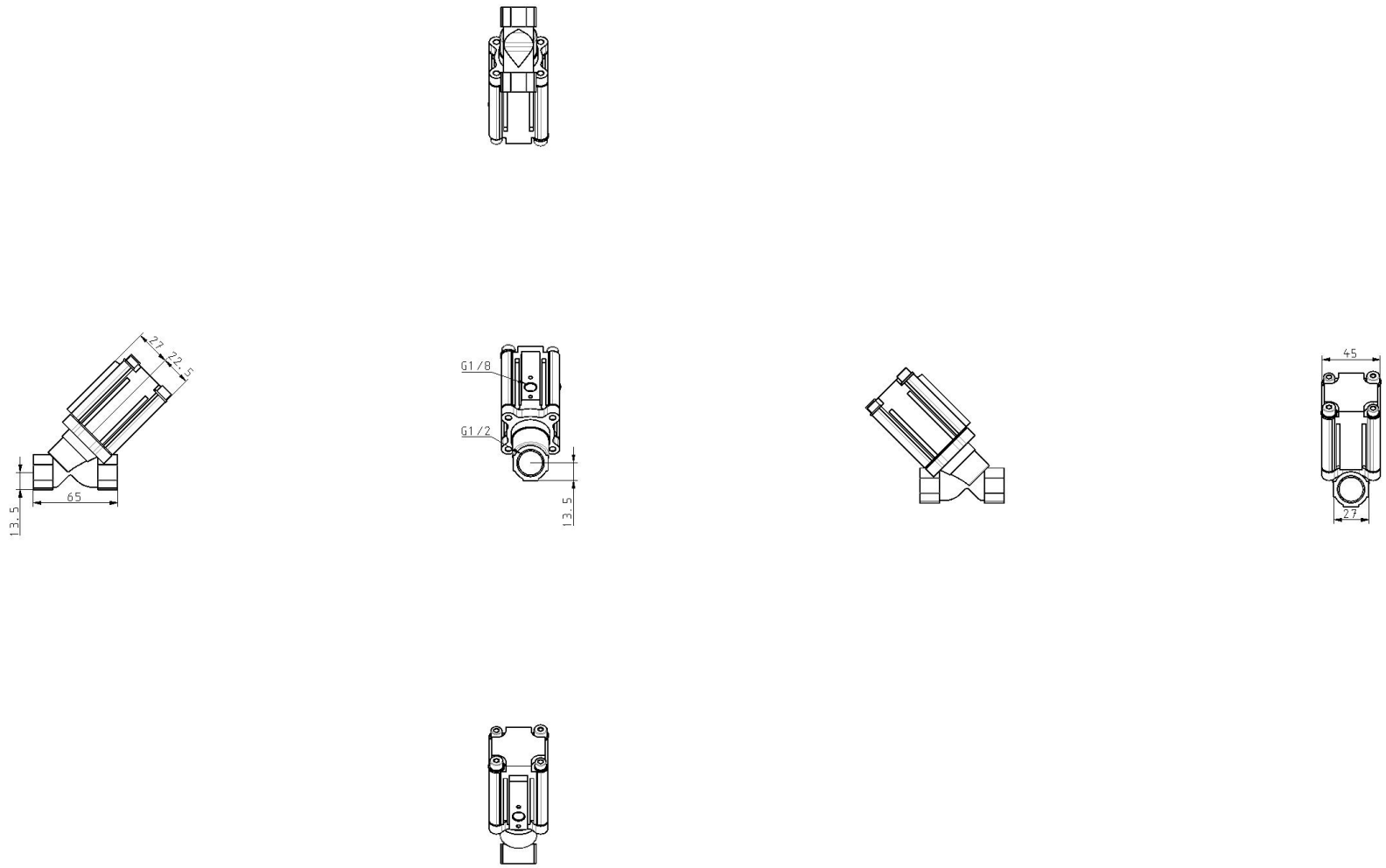

Specifications are subject to change without prior notice and any obligation on the part of the manufacturer.

Constructions

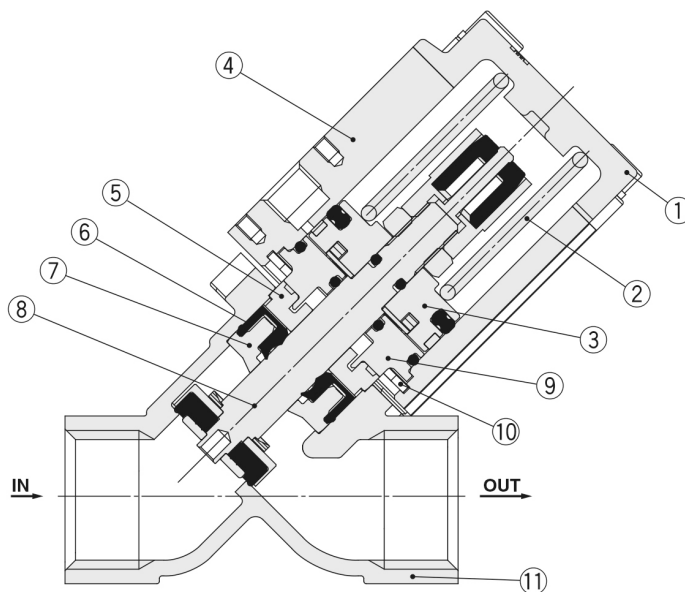

Component Parts

No.	Description	Material
1	Cover	Stainless steel 316L equivalent
2	Spring	Stainless steel 304
3	Piston assembly	Al, FKM, PTFE, Stainless steel 304
4	Housing	Al
5	Guide bushing	PPS
6	Squeeze seal with scraper function	FKM
7	Resin scraper	PEEK
8	Main valve assembly	FKM, Stainless steel 316L
9	Bushing assembly	Al, FKM
10	Inverted internal retaining ring	Fe
11	Body	CAC or Stainless steel 316L equivalent

Additional information

Catalogue

[VXB-B_EU.pdf](#)