

Standard - MHR2 MHR2-15R

Datasheet

General series information

- Maximum gripping force 59 N at 0.5 MPa
- Double acting
- Repeatability: ± 0.01 mm
- Max. operating frequency: 180 c.p.m.

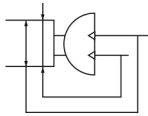

Rotary actuated air gripper

Standard specifications

Nominal Size	15
Port Location	R (Body Side Direction)
Maximum operating pressure	0.6 MPa
Minimum operating pressure	0.15 MPa
Maximum ambient temperature	60 °C
Minimum ambient temperature	0 °C
Repeatability	± 0.01 mm
Port size	M3
Applicable fluid	Air
Lubrication	Non lube
Action	Double acting
Holding force at 0.5 MPa, external hold	24 N
Holding force at 0.5 MPa, internal hold	25 N
Opening / closing stroke (both sides), closing	14 mm
Opening / closing stroke (both sides), opening	22 mm
Weight	0.180 Kg

Dimensions

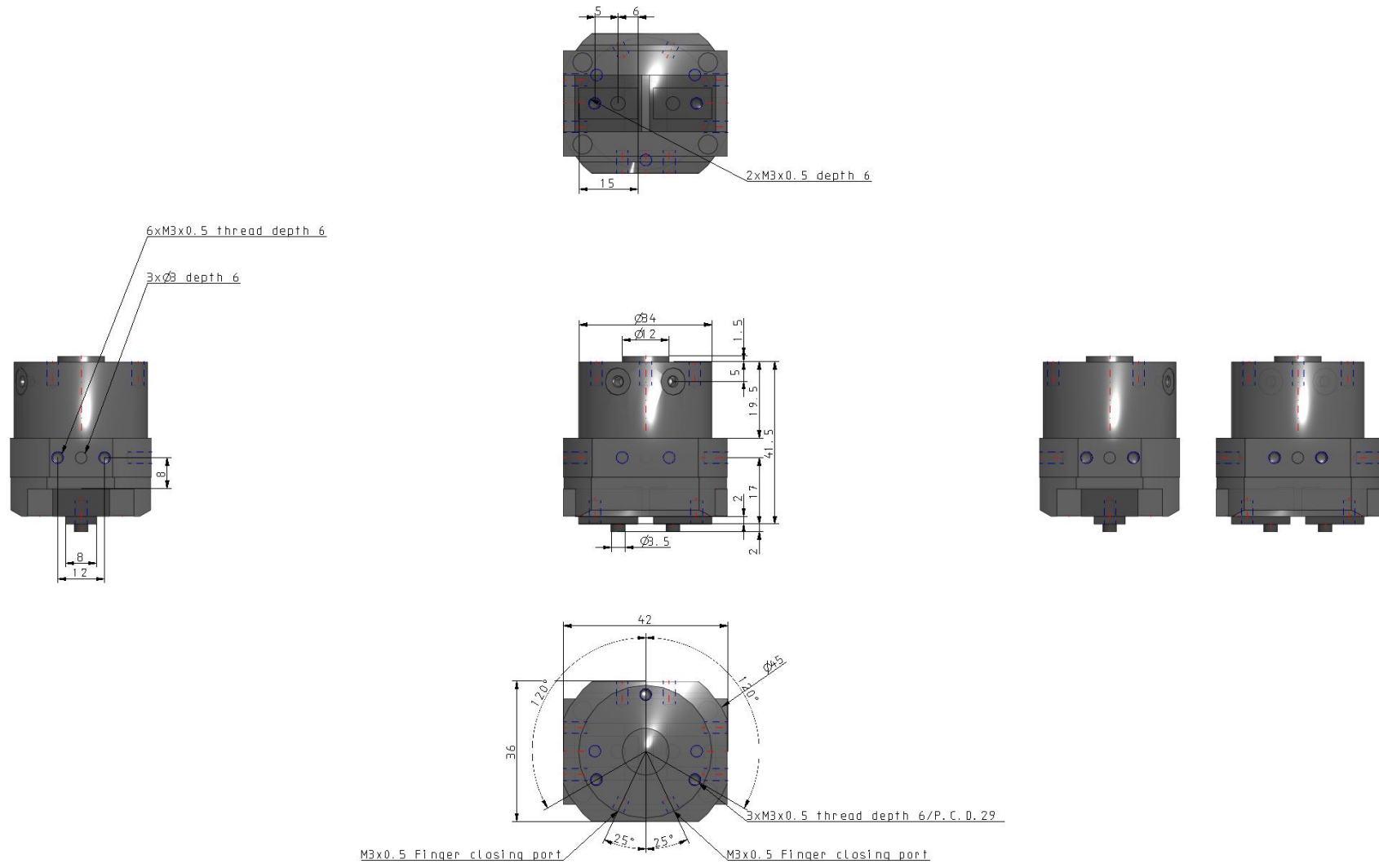

Specifications are subject to change without prior notice and any obligation on the part of the manufacturer.

Constructions

MHR2

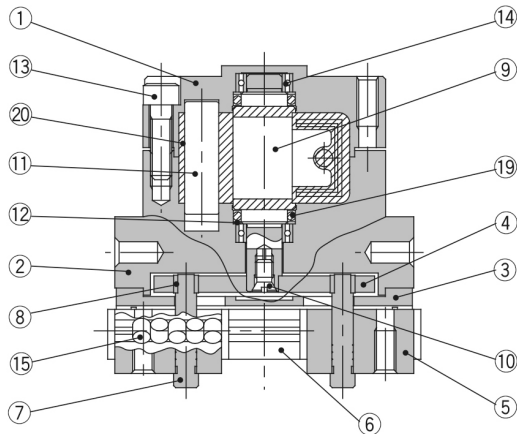

MDHR2

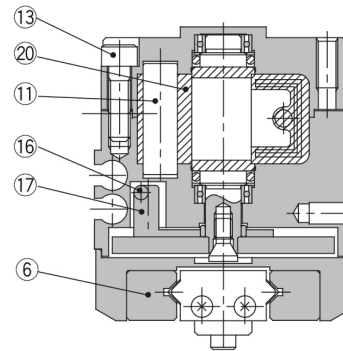
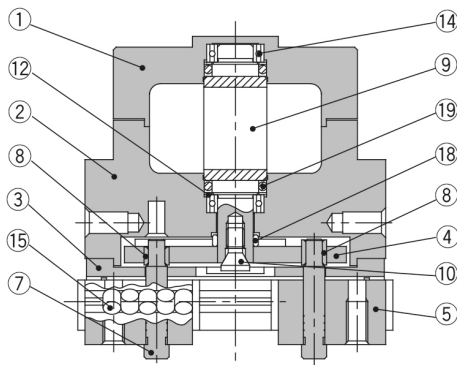

Component Parts

No.	Description	Material	Note
①	Body	Aluminum alloy	Anodized
②	Adaptor Body	Aluminum alloy	Anodized
③	Guide holder	Stainless steel	
④	Cam	Cold rolled steel	Nitriding
⑤	Finger ass'y	Stainless steel	Heat treatment
⑥	Guide	Stainless steel	Heat treatment
⑦	Pin	Carbon steel	Heat treatment Electroless nickel plated
⑧	Pin roller	Stainless steel	Nitriding
⑨	Vane shaft	Stainless steel	M□HR2-30 is carbon steel
⑩	Shaft bolt	Chrome molybdenum steel	Zinc chrome

Component Parts

No.	Description	Material	Note
⑪	Stopper	Resin	
⑫	Back-up ring	Stainless steel plate	
⑬	Hexagon socket head bolt	Stainless steel	
⑭	Bearing	High carbon chrome steel	
⑮	Cylindrical roller	Stainless steel	
⑯	Magnet	Magnetic material	
⑰	Magnet holder	Aluminum alloy	Anodized
⑱	Roller	Stainless steel	Nitriding
⑲	O ring	NBR	
⑳	Stopper packing	NBR	

Additional information

Catalogue

[MHR2_EU.pdf](#)

Operation manuals

[OM_MHR2_OMG0033EN.pdf](#)