

ARG20(K)~40(K)-B, Regulator w/Built-in Pressure Gauge ARG20-F01G1H-B

Datasheet

General series information

- Body size: 20, 30, 40.
- One-touch mounting/removal of the pressure gauge cover.

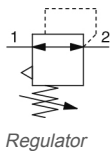

Standard specifications

Size	20
Reverse Flow Function	Regulator, Standard
Thread	F (G)
Port Size	01 (1/8)
Bracket	None
Pressure Gauge Angle	G1 (0°)
Set Nut	H (Set Nut)
Set pressure	0.05 to 0.85 MPa
Exhaust Mechanism	Relieving
Knob	Downward
Pressure Unit	MPa
0.4 MPa Setting	No
Special Mounting Angle	None
Pressure medium	Air
Maximum temperature of pressure medium	60 °C
Minimum temperature of pressure medium	-5 °C (with no freezing)
Maximum operating pressure	1.0 MPa
Proof pressure	1.5 MPa
Maximum ambient temperature	60 °C
Minimum ambient temperature	-5 °C (with no freezing)
Conform to the European RoHS Directive	Conform

Approvals	No need
Weight	0.240 Kg

Dimensions

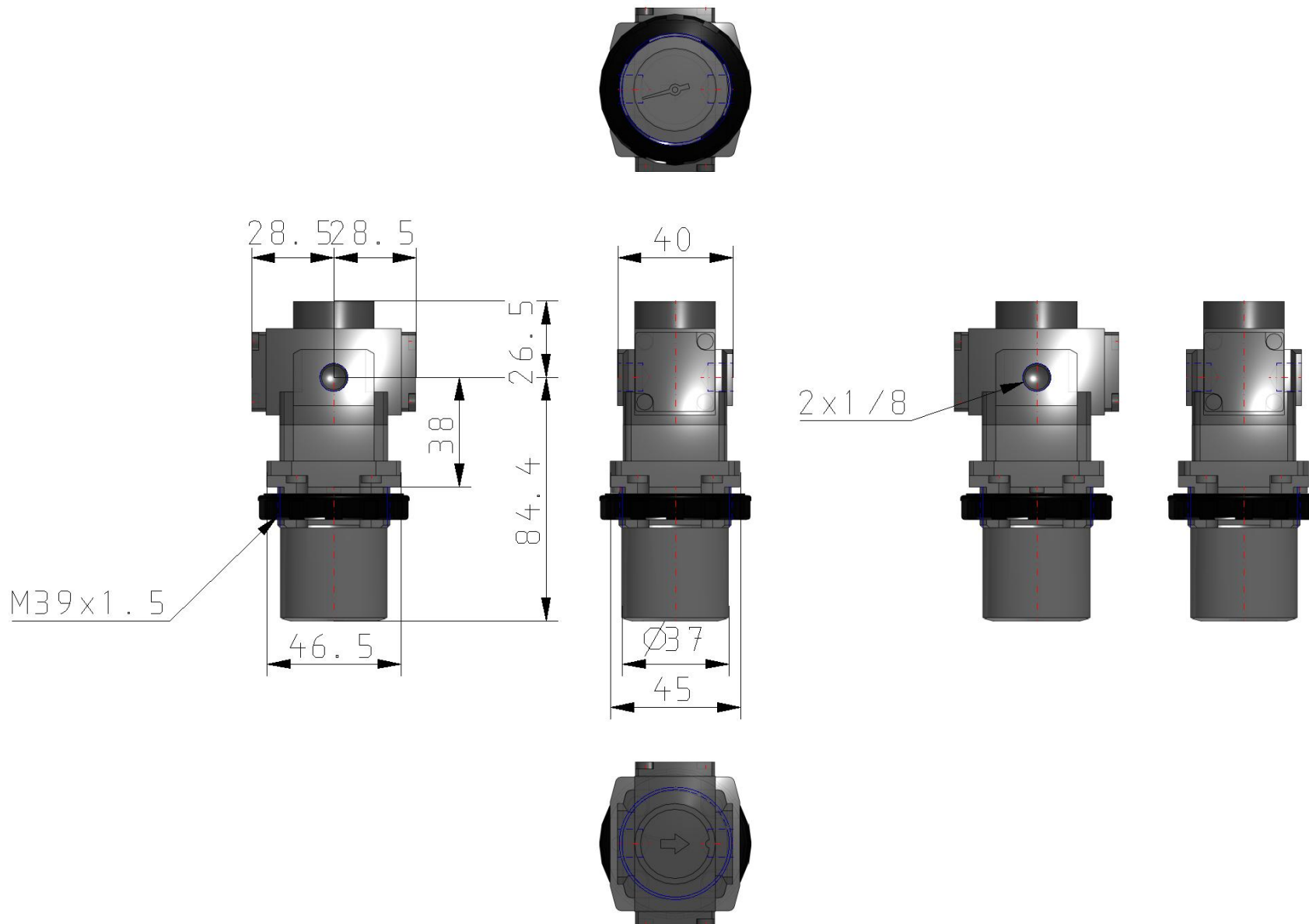

Specifications are subject to change without prior notice and any obligation on the part of the manufacturer.

Constructions

ARG20K-B to ARG40K-B (Regulator with Built-in Pressure Gauge with Backflow Function)

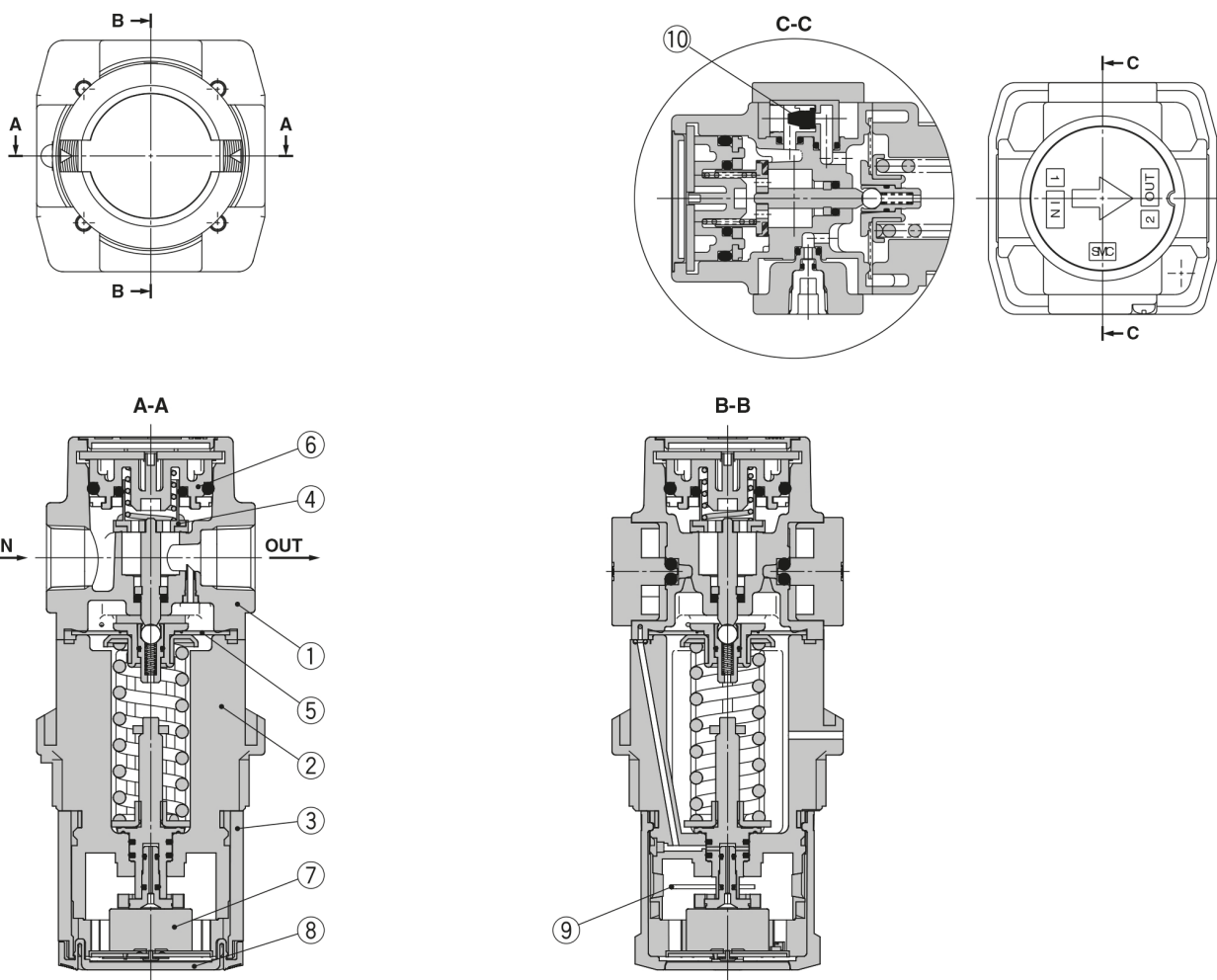

Component Parts

No.	Description	Material	Colour
1	Body	ADC	White
2	Bonnet	PBT	White
3	Knob	POM	Grey

Replacement Parts

No.	Description	Material	Part no.		
			ARG20(K)-B	ARG30(K)-B	ARG40(K)-B
4	Valve	Brass, HNBR	AR20P-410S	AR30P-410S	AR40P-410S
5	Diaphragm assembly	Weatherable NBR	AR20P-150AS	AR30P-150AS	AR40P-150AS
6	Valve guide assembly	POM/NBR	AR20P-050AS	AR30P-050AS	AR40P-050AS
7	Pressure gauge*1	—	GB2-10AS	GB3-10AS	GB4-10AS
8	Pressure gauge cover	PC	ARG20P-400S	ARG30P-400S	ARG40P-400S
9	Clip	Stainless steel	ARG20P-420S	ARG30P-420S	ARG40P-420S
10	Check valve assembly*2	—	AR23KP-020AS		

*1 Only the standard part numbers are listed in the pressure gauges. For the optional part numbers, refer to page 24.

*2 Check valve assembly is applicable for a filter regulator with backflow function (ARG20K-B to ARG40K-B) only. Assembly of a check valve cover, check valve body assembly and 2 mounting screws

Additional information

Catalogue [ACG-ARG-AWG-B-A_EU.pdf](#)

Operation manuals [arg_ar_-omi0085.pdf](#)