

CXSWM, Dual Rod Cylinder, Double Rod, Slide Bearing CXSWM20-50

Datasheet

- Dual rod cylinder: double rod
- Bore sizes: 6, 10, 15, 20, 25, 32 (mm)
- Strokes from 10mm through 100mm depending upon bore size
- Variety of switches and a variety of lead wire lengths

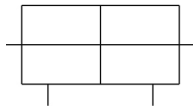

Double-acting cylinder with double piston rod

Standard specifications

Thread port	M5 (Rc (PT) for sizes 25 to 32)
Bore Size	20mm
Stroke	50mm
Auto Switch	No Switch
Number	2 pcs. [Or None in the Case of No Switch]
Pressure medium	Compressed Air
Maximum temperature of pressure medium with magnet	60 °C
Minimum temperature of pressure medium with magnet	-10 °C [without condensation]
Maximum operating pressure	0.70 MPa
Minimum operating pressure	0.01 MPa
Proof pressure	1.05 MPa
Maximum ambient temperature with magnet	60 °C
Minimum ambient temperature	-10 °C
Number of pneumatic connections	2 pcs.
Pneumatic input connection	M5 x 0.8
Pneumatic output connection	M5 x 0.8
Mode of operation of drive	Double acting
Theoretical cylinder force, advance stroke (at 0.5 MPa)	236 N
Theoretical cylinder force, return stroke (at 0.5 MPa)	236 N
Maximum piston speed	500 mm/s

Type of cushioning	Rubber bumper
Maximum stroke reduction per side	5 mm
Type of stroke reduction	Both sides
Tolerance of torsion	0.2°
Weight	0.900 Kg

Constructions

CXSWM Slide bearing

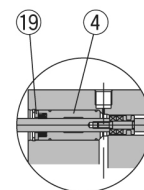
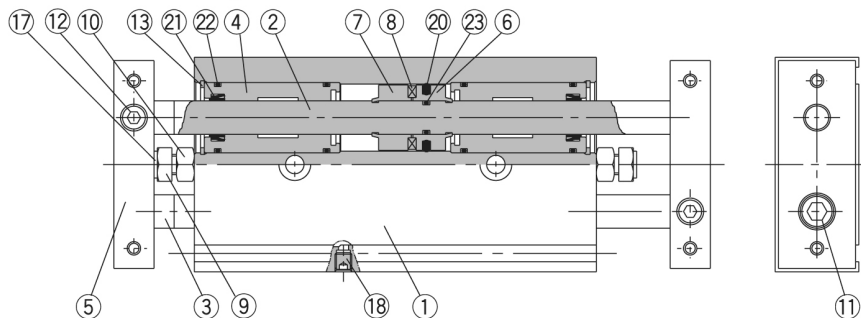
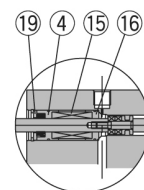
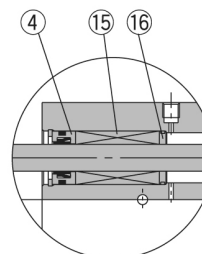
CXSWM6

CXSWL6

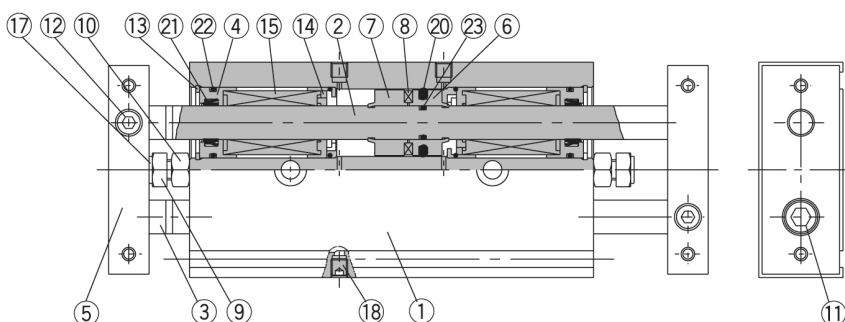
CXSWL10, 15

CXSWL Ball bushing bearing

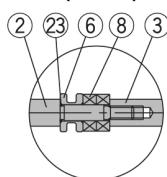
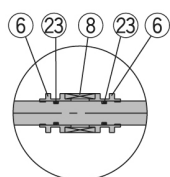
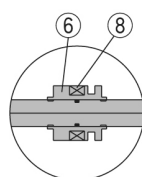

(Piston)

CXSW□6

CXSW□10

CXSW□25, 32

Parts list

No.	Description	Material	Note
1	Housing	Aluminum alloy	Hard anodized
2	Piston rod A	Carbon steel	Hard chrome plated
3	Piston rod B	Carbon steel	Hard chrome plated
4	Rod cover/Bearing	Aluminum alloy	
5	Plate	Aluminum alloy	Hard anodized
6	Piston A	Aluminum alloy	Chromated
7	Piston B	Aluminum alloy	Chromated
8	Magnet	Magnetic material	
9	Bumper bolt	Carbon steel	Nickel plated
10	Hexagon nut	Carbon steel	Nickel plated
11	Hexagon socket head cap screw	Chromium steel	Nickel plated
12	Hexagon socket head set screw	Chromium steel	Nickel plated

Note) Piston rod for CXSWL is quenched.

Parts list

No.	Description	Material	Note
13	Snap ring	Special steel	Nickel plated
14	Bumper holder	Synthetic resin	
15	Ball bushing	—	
16	Bearing spacer	Synthetic resin	
17	Bumper	Polyurethane	
18	Plug	Chromium steel	Nickel plated
19	Seal retainer	Aluminum alloy	
20*	Piston seal	NBR	
21*	Rod seal	NBR	
22*	O-ring	NBR	
23	O-ring	NBR	

* Seal kits consist of items 20 through 22, and can be ordered by using the seal kit number corresponding to each bore size. However for CXSWL15, there are two types of O-ring (22). For other sizes, one type of O-ring is available. For CXSWL6, aluminum alloy is used for 16.

Additional information

Catalogue

[CXS_EU.pdf](#)