

# CXSL, Dual Piston Rods, Ball Bushing Bearing

## CXSL10-15

### Datasheet

### General series information

- Dual rod cylinder with ball bearing slide
- Bore sizes: 6, 10, 15, 20, 25, 32 (mm)
- Strokes from 10mm through 100mm depending upon bore size
- Variety of switches and a variety of lead wire lengths

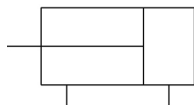

Double-acting, single-rod cylinder

### Standard specifications

Bore Size	10 mm
Thread	ø6-ø20 Bore: M Thread; ø25,ø32 Bore: Rc 1/8
Lube-retainer	Without Stable Lubrication Function
Stroke	15 mm
Auto Switch	No Switch
Lead Wire or Prewired Connector	0.5m [Or None in the Case of No Switch]
Number	2 pcs. [Or None in the Case of No Switch]
Pressure medium	Air (non-lube)
Maximum operating pressure	0.7 MPa
Minimum operating pressure	0.1 MPa
Proof pressure	1.05 MPa
Maximum ambient temperature	60 °C
Minimum ambient temperature	-10 °C
Number of pneumatic connections	2 pcs.
Mode of operation of drive	Double acting
Type of cushioning	Rubber Bumper
Port size	M5
Piston speed	30 - 800 mm/s
Stroke adjustable range	0 to – 5 mm compared to the standard stroke

# Dimensions

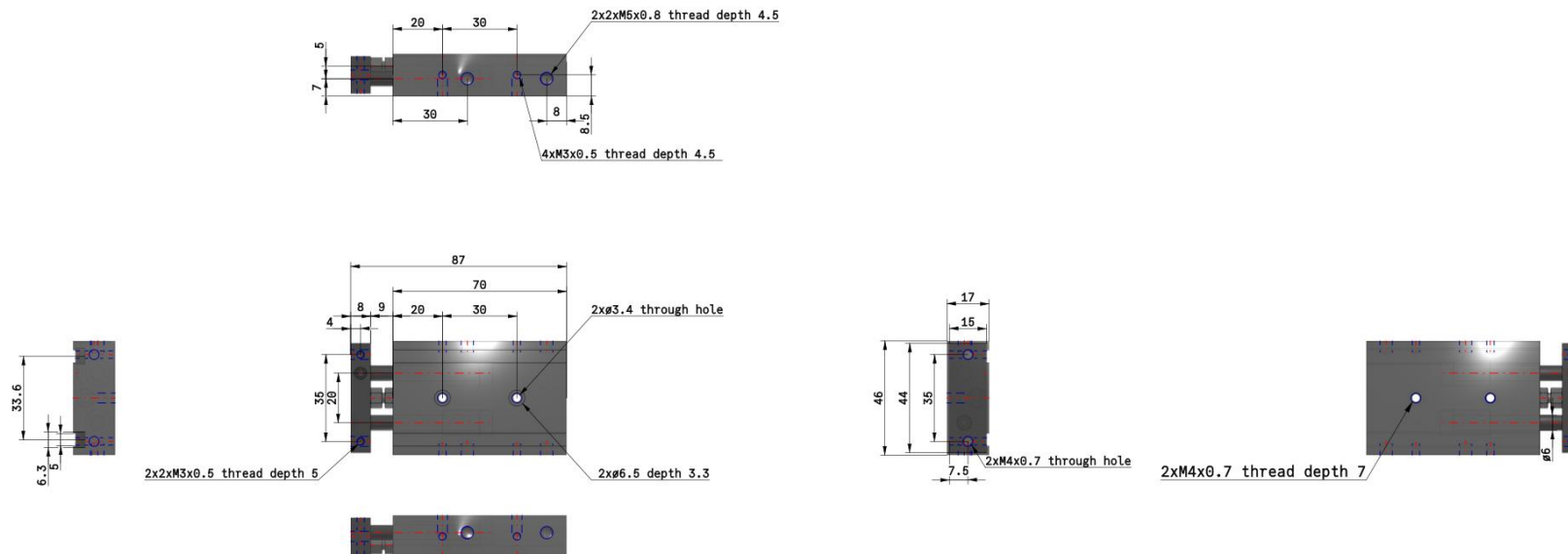

## Constructions

### CXSL10

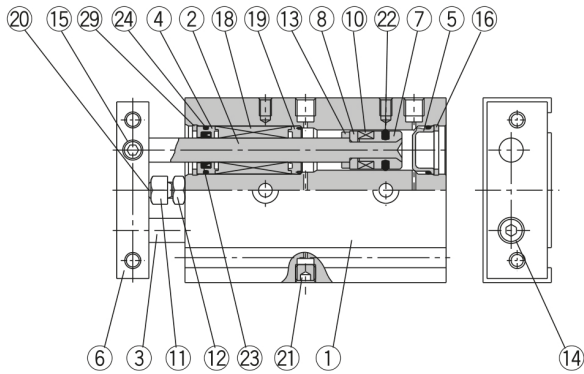

#### Parts list: Standard piping

No.	Description	Material	Note
1	<b>Housing</b>	Aluminum alloy	Hard anodized
2	<b>Piston rod A</b>	Special steel	Hard chrome plated
3	<b>Piston rod B</b>	Special steel	Hard chrome plated
4	<b>Rod cover/Bearing</b>	Aluminum alloy	
5	<b>Head cover</b>	Special steel <sup>Note 1)</sup>	
6	<b>Plate</b>	Aluminum alloy	Hard anodized
7	<b>Piston A</b>	Aluminum alloy	Chromated
8	<b>Piston B</b>	Aluminum alloy	Chromated
9	<b>Bumper A</b>	Polyurethane	
10	<b>Magnet</b>	Magnetic material	
11	<b>Bumper bolt</b>	Carbon steel	Nickel plated
12	<b>Hexagon nut</b>	Carbon steel	Nickel plated
13	<b>Bumper B</b>	Polyurethane	
14	<b>Hexagon socket head cap screw</b>	Chromium steel	Nickel plated
15	<b>Hexagon socket head set screw</b>	Chromium steel	Nickel plated
16	<b>Snap ring</b>	Special steel	Nickel plated
17	<b>Bumper holder</b>	Synthetic resin	



Note 1) Anodized aluminum alloy for CXSL6.

#### Parts list

No.	Description	Material	Note
18	<b>Ball bushing</b>	—	
19	<b>Bearing spacer</b>	Synthetic resin <sup>Note 2)</sup>	
20	<b>Bumper</b>	Polyurethane	
21	<b>Plug</b>	Chromium steel	Nickel plated
22	<b>Piston seal</b>	NBR	
23	<b>Rod seal</b>	NBR	
24	<b>O-ring</b>	NBR	
25	<b>Head cover B</b>	Aluminum alloy	Nickel plated
26	<b>Seal retainer</b>	Aluminum alloy	
27	<b>Port spacer</b>	Aluminum alloy	
28	<b>Steel ball</b>	Special steel	Hard chrome plated
29	<b>Snap ring B</b>	Special steel	Nickel plated

Note 2) Aluminum alloy for CXSL6.

## Additional information

Catalogue

[CXS\\_EU.pdf](#)