

ZK2*A, Vacuum Unit, Ejector System, Single Unit ZK2A12K5TLA-08

Datasheet

General series information

- Dual 2 port valve (Release valve/Supply valve).
- Efficient 2-stage ejector.
- Pressure sensor / switch variations with energy-saving function available.

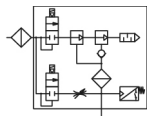

Dual stage modular ejector - with valves and switch

Standard specifications

Body type	A (Single Unit - Silencer Exhaust)
Nominal Nozzle Size	12 (ø1.2)
Supply Valve / Release Valve	K (N.C. / N.C.)
Rated Voltage	5 (24 VDC)
Pressure Sensor/Digital Pressure Switch for Vacuum Spec.	T (Pressure Sensor / -100 to 100 kPa / Analogue Output 1 to 5 V)
Supply Valve/Release Valve/Digital Pressure Switch for Vacuum Connector Spec.	L [L-type Plug Connector - w/ Lead Wire with Connector - w/ Lead Wire with Connector for Pressure Switch/sensor]
Vacuum (V) Port	08 [ø8 One-touch Fitting (Metric)]
Bracket	None
Individual Release Pressure Supply	None
Screwdriver Operation Type Long Lock Nut	None
Vacuum Break Flow Adjustment	None
Exhaust Interference Prevention Valve	None
Pressure medium	Air
Proof pressure	500 kPa
Conform to the European RoHS Directive	Conform
Current consumption	15 mA or less
Element nominal filtration rating	30 µm
Repeatability	±0.2 % F.S.
Linearity	±0.4 % F.S.

Applicable fluid	Air
Rated pressure range	-100 - 100 kPa
Power supply voltage	12 to 24 VDC $\pm 10\%$, Ripple (p-p) 10 % or less
Supply pressure range (MPa)	0.3 - 0.6 MPa
Noise level	75 dB
Standard supply pressure	0.35 MPa
Maximum vacuum pressure	-91 kPa
Air consumption	58 l/min
Operating temperature range	0 - 50 °C
Vibration resistance	30 m/s ²
Impact resistance	150 m/s ²
Accuracy	$\pm 2\%$ F.S. (Ambient temperature at 25 °C)
Valve type of actuation	Supply valve: N.C. Release valve: N.C.
Valve configuration	Pilot operated dual 2-port
Valve operating pressure range	0.3 - 0.6 MPa
Valve construction	Popper seal
Valve rated voltage	24 VDC
Valve power consumption	0.4 W
Valve lead wire (ZK2-LV**-A)	Cross section: 0.2 mm ² (AWG24) Insulator O.D.: 1.4 mm
Suction filter, Filtration area	510 mm ²
Output voltage	1 - 5 VDC
Effect of power supply	$\pm 0.8\%$ F.S.
Sensor temperature range	Stored: -20 to 70 °C (No condensation or freezing)
Sensor humidity range	Operating/Stored: 35 to 85 % RH (No condensation)
Sensor temperature characteristics	$\pm 2\%$ F.S. or less (Ambient temperature: 25 °C reference)
Case material	Resin case: PBT
Pressure sensing section material	Sensor pressure receiving area: Silicon, O-ring: HNBR
Sensor lead wire	Oil-resistant vinyl cabtire cable (elliptic) 3 cores, 2.7 x 3.2 mm, 3 m Cross section: 0.15 mm ² Insulator O.D.: 0.9 mm
Analogue voltage output	Approx. 1 k Ω
Max. suction flow, Silencer exhaust/Complex exhaust	61 l/min
Weight	0.100 Kg

Dimensions

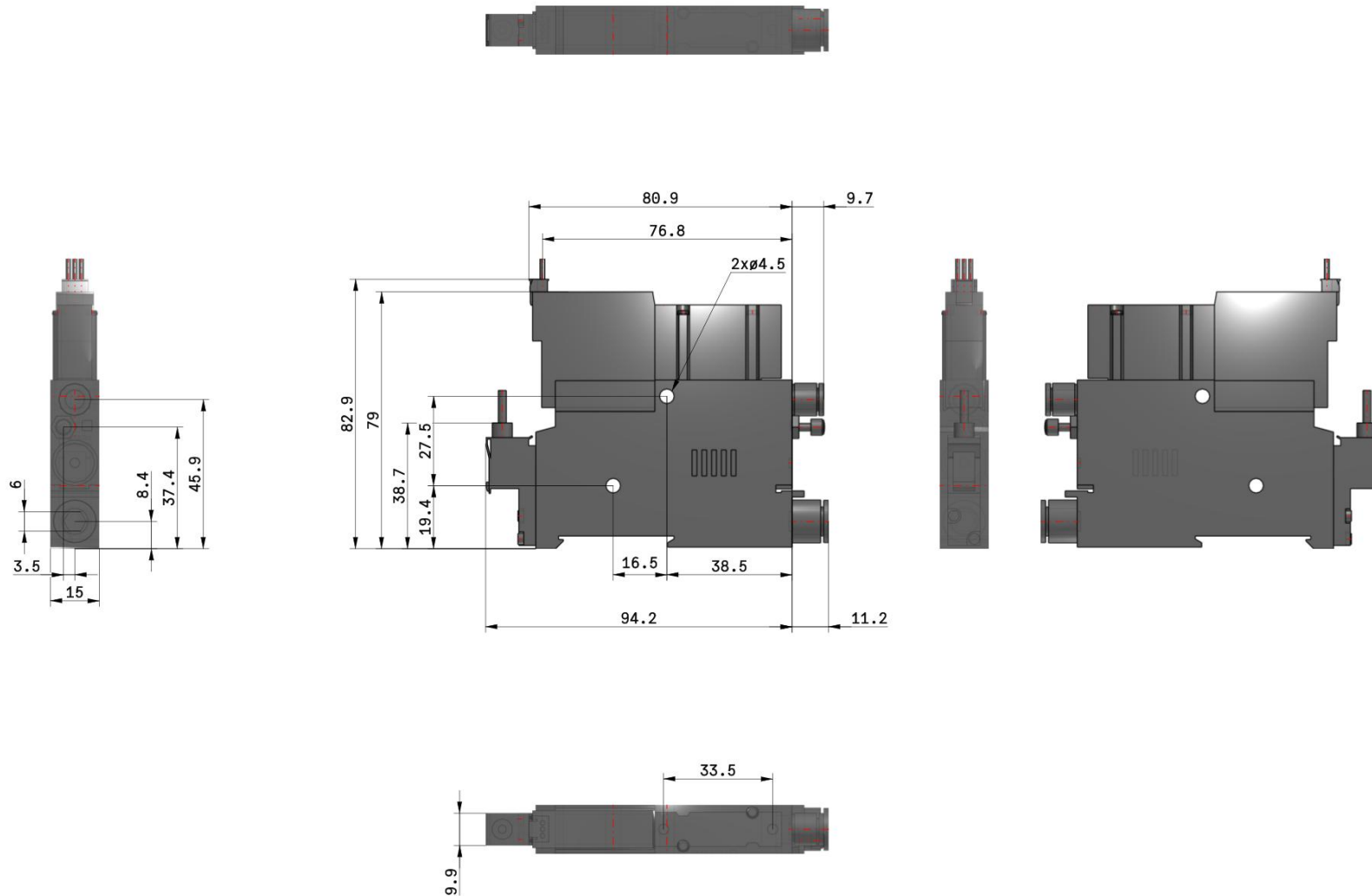

Constructions

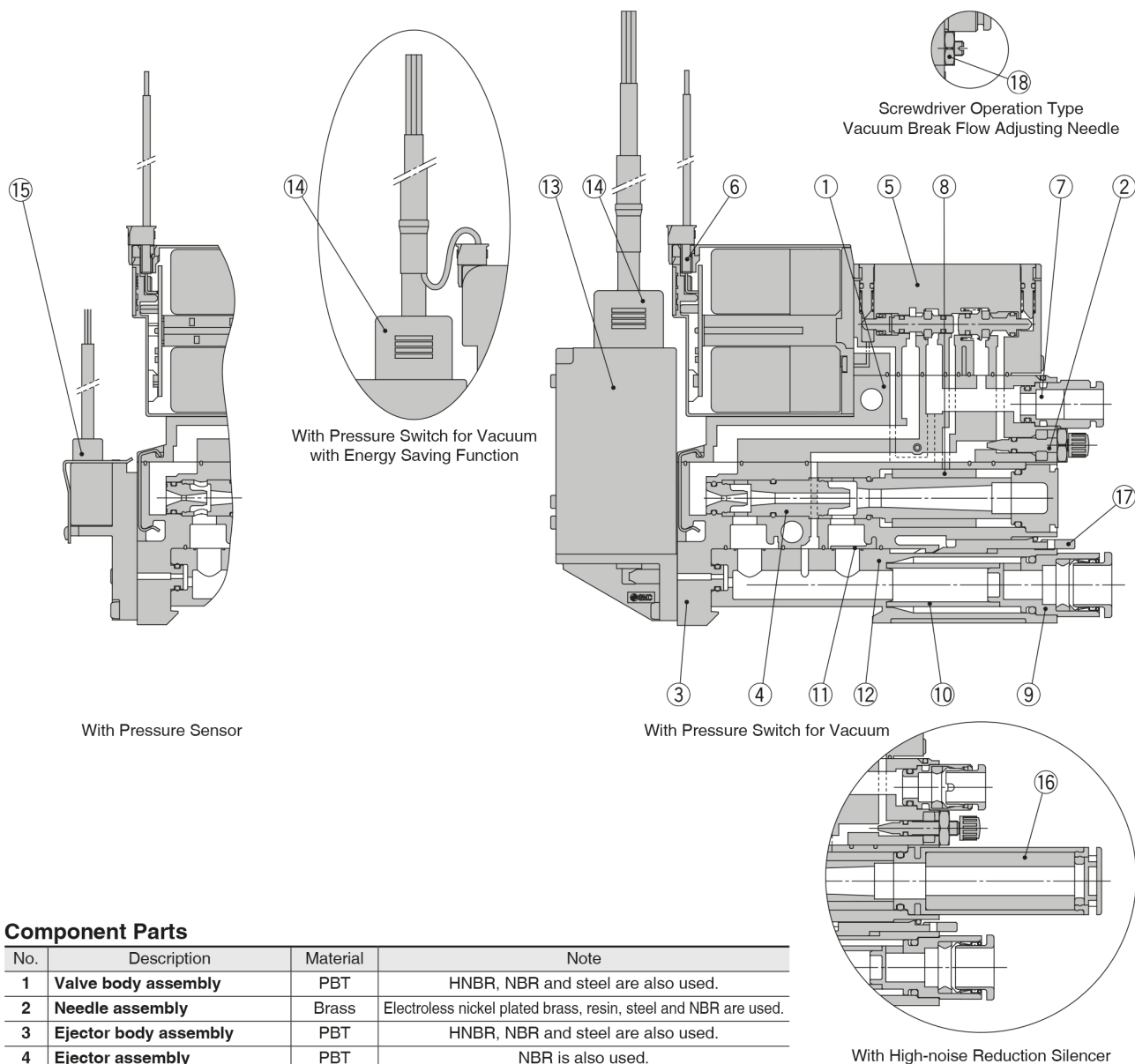

Component Parts

No.	Description	Material	Note
1	Valve body assembly	PBT	HNBR, NBR and steel are also used.
2	Needle assembly	Brass	Electroless nickel plated brass, resin, steel and NBR are used.
3	Ejector body assembly	PBT	HNBR, NBR and steel are also used.
4	Ejector assembly	PBT	NBR is also used.

Replacement Parts

No.	Description	Note
5	Valve assembly	—
6	Connector assembly	Connector for solenoid valve 3 wire (For valve type K/R), 2 wire (For valve type J)
7	One-touch fitting assembly	Metric size: $\varnothing 6$, Inch size: $\varnothing 1/4$ "
8	Sound absorbing material	10 pcs. per set
9	Vacuum port adapter assembly	With One-touch fitting and filter element
10	Filter element	Nominal filtration rating: 30 μm , 10 pcs. per set
11	Body gasket	Gasket integrated with the exhaust interference prevention valve, 10 pcs. per set
12	Filter case	Case body: Polycarbonate (Refer to the Specific Product Precautions on page 47.) Clear filter case: without a port for the pressure switch or sensor, Opaque filter case: with a port for the pressure switch or sensor
13	Vacuum pressure switch assembly	With 2 screws and 1 gasket
14	Lead wire with connector	—
15	Pressure sensor assembly	With 2 screws and 1 gasket
16	High-noise reduction silencer case assembly	With sound absorbing material (Part number: ZK2-SE4-6-A)
17	Release lever	10 pcs. per set
18	Lock nut	10 pcs. per set

Additional information

Catalogue	ZK2A-C_EU.pdf
Declaration of conformity	newDoC_ZK2-A_TF1Z208EN.pdf newDoC_ZK2-A_TF124-124EN.pdf
Installation manuals	IM_ZK2-A_TF2Z368EN-B.pdf
Operation manuals	OM_ZK2-ZSV-A_OM00501EN-C.pdf OM_ZK2xA_OM01301EN.pdf