

C(D)QM, Compact Cylinder, Guide Rod Type CQMB20-10

Datasheet

The CQM is a compact cylinder integrated with a guide rod and plate. The series is available in 12, 16, 20, 25, 32, 40, 50, 63, 80 and 100mm bore sizes with the same mounting dimensions as the CQ2. The guide rod and plate allow work to be directly mounted. The CQM series offers 4 times the lateral load resistance of the CQ2K and non-rotating accuracy of $\pm 0.2^\circ$.



Double-acting cylinder with cushioning adjustable at both ends, single piston rod

Standard specifications

| | |
|---|-----------------------------|
| Magnet | None |
| Mounting | B [Through Hole (Standard)] |
| Bore Size | Ø20 mm |
| Port Thread | M Thread |
| Rc | |
| Stroke | 10mm |
| Auto Switch | No Switch |
| Lead Wire or Prewired Connector | 0.5 m |
| Number | 2 pcs. |
| Pressure medium | Compressed air |
| Minimum temperature of pressure medium | -10 °C (with no freezing) |
| Maximum operating pressure | 1.0 MPa |
| Minimum operating pressure | 0.1 MPa |
| Proof pressure | 1.5 MPa |
| Maximum ambient temperature | 70 °C |
| Minimum ambient temperature | -10 °C (with no freezing) |
| Number of pneumatic connections | 2 pcs. |
| Pneumatic input connection | M5 |
| Pneumatic exhaust connection | M5 |
| Theoretical cylinder force, advance stroke (at 0.5 MPa) | 157 |

| | |
|--|----------------------------|
| Theoretical cylinder force, return stroke (at 0.5 MPa) | 118 |
| Maximum piston speed | 500 mm/s |
| Type of cushioning | Rubber bumper on both ends |
| Piston rod end | Without thread |
| Non-rotating accuracy of plate | $\pm 0.1^\circ$ |
| Allowable rotational torque | 0.32N·m |
| Weight | 0.107 Kg |

Dimensions

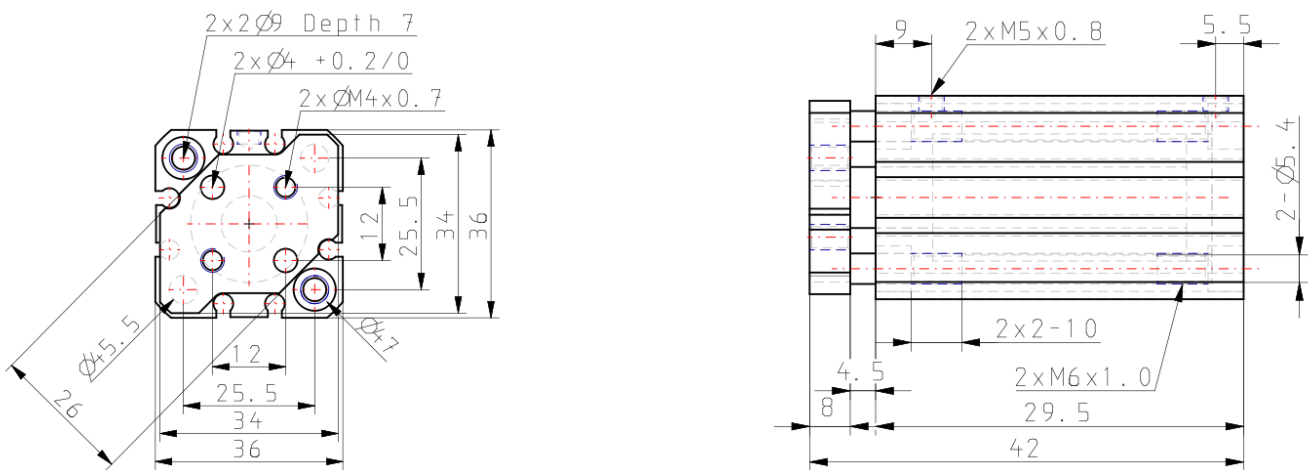

Constructions

ø12 to ø25

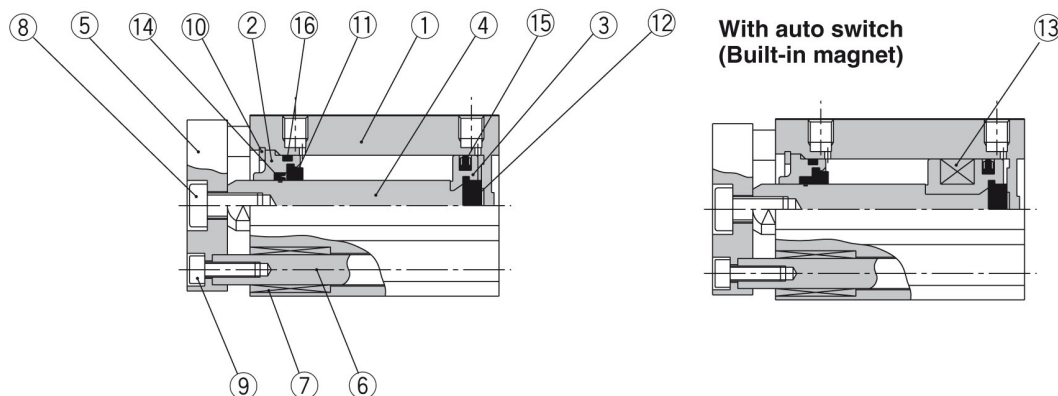

Component Parts

| No. | Description | Material | Note |
|-----|--------------------------------------|--------------------------------|--------------------|
| 1 | Cylinder tube | Aluminium alloy | Hard anodised |
| 2 | Collar | Aluminium alloy | Anodised |
| 3 | Piston | Aluminium alloy | Chromated |
| 4 | Piston rod | Stainless steel | |
| 5 | Plate | Aluminium alloy | Anodized |
| 6 | Guide rod | Stainless steel | Hard chrome plated |
| 7 | Bushing | Oil-impregnated sintered alloy | |
| 8 | Hexagon socket head cap screw | Carbon steel | Nickel plated |
| 9 | Hexagon socket head cap screw | Carbon steel | Nickel plated |
| 10 | Snap ring | Carbon tool steel | Phosphate coated |
| 11 | Bumper A | Urethan | |
| 12 | Bumper B | Urethan | |
| 13 | Magnet | — | |
| 14 | Rod seal | NBR | |
| 15 | Piston seal | NBR | |
| 16 | Gasket | NBR | |

Additional information

Catalogue

[CQM_EU.pdf](#)