

## VXB, Air Operated, Angle Seat Valve VXB215FA

Datasheet

### General series information

- For steam (can also be used with air and water)
- Low pressure loss due to angle seat structure
- Low leakage of 10 cm<sup>3</sup>/min or less (rubber seal)
- Long service life: 3 million cycles (steam) 5 million cycles (air)
- Body material: stainless steel 316L equivalent, bronze (CAC)

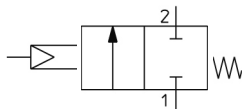

*Directional control valve 2/2-way valve, closed normal position With pressure control Return with mechanical control spring*

### Standard specifications

Body material/Port size/Orifice diameter	F (Stainless Steel, 316 L Equivalent, 3/4, Ø18 mm)
Pressure Type	Standard
Thread Type	A (G)
Indicator	No
Special Option	None
Maximum temperature of pressure medium	183 °C
Maximum operating pressure	1 MPa
Proof pressure	2.4 MPa
Maximum ambient temperature	60 °C
Minimum ambient temperature	-20 °C
Pneumatic input connection	G 1/8
Orifice diameter	Ø18 mm
Weight	0.680 Kg

# Dimensions

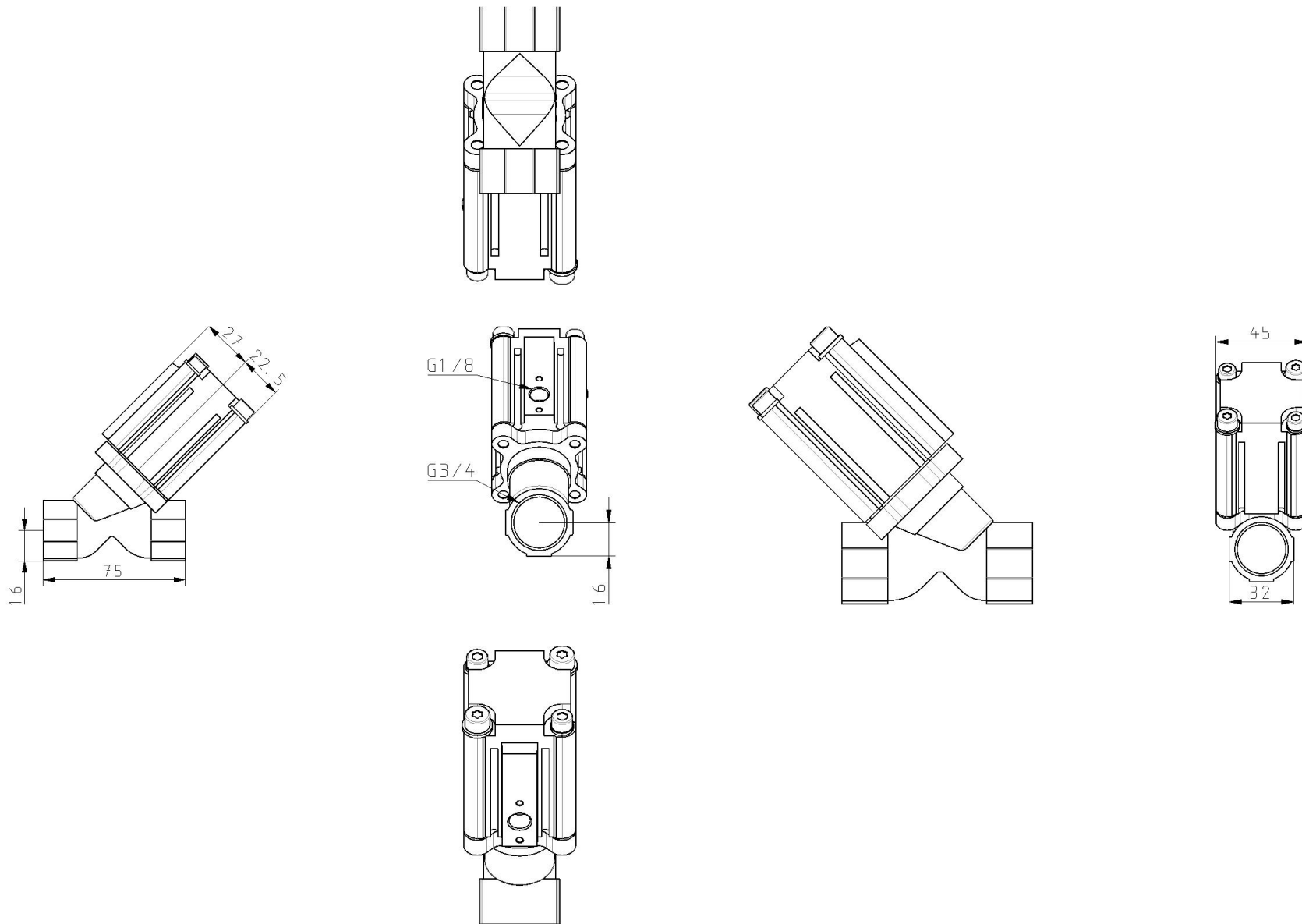

## Constructions

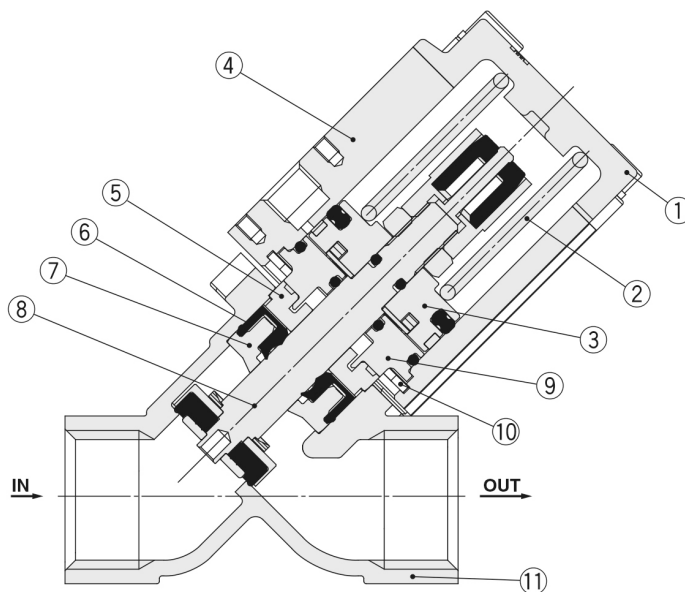

### Component Parts

No.	Description	Material
1	Cover	Stainless steel 316L equivalent
2	Spring	Stainless steel 304
3	Piston assembly	Al, FKM, PTFE, Stainless steel 304
4	Housing	Al
5	Guide bushing	PPS
6	Squeeze seal with scraper function	FKM
7	Resin scraper	PEEK
8	Main valve assembly	FKM, Stainless steel 316L
9	Bushing assembly	Al, FKM
10	Inverted internal retaining ring	Fe
11	Body	CAC or Stainless steel 316L equivalent

## Additional information

Catalogue

[VXB-B\\_EU.pdf](#)